

6

5

4

3

2

1

PART NO  
MOLEX ID  
CAVITY ID

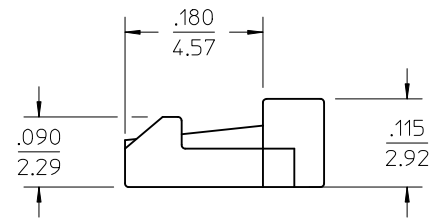
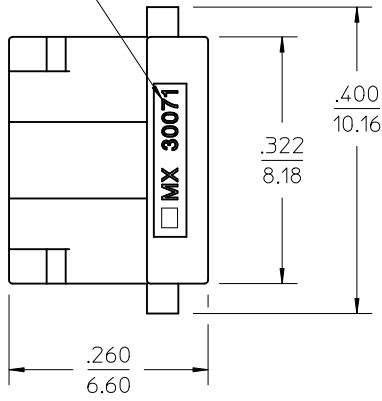
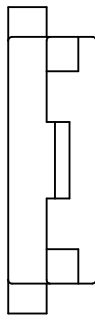

NOTES:

- 1. MATERIAL: NYLON 6/6, 94V-2, COLOR: SEE CHART
- 2. FINISH: NOT APPLICABLE
- 3. PRODUCT SPEC: PS-5556-003
- 4. PACKAGING SPECIFICATION: PK-30071-0000
- 5. CPA FOR USE WITH ALL 30067 RECPT HOUSINGS AND SELECT 5557 RECPT HOUSINGS (5557 HSG MUST HAVE STANDARD LATCH AND PULL TABS AS SHOWN)

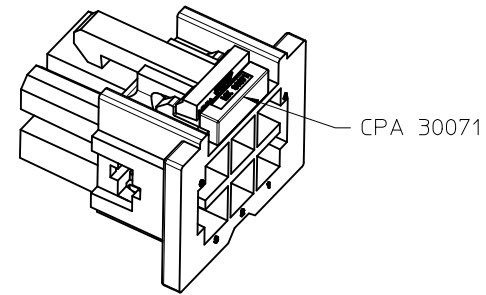
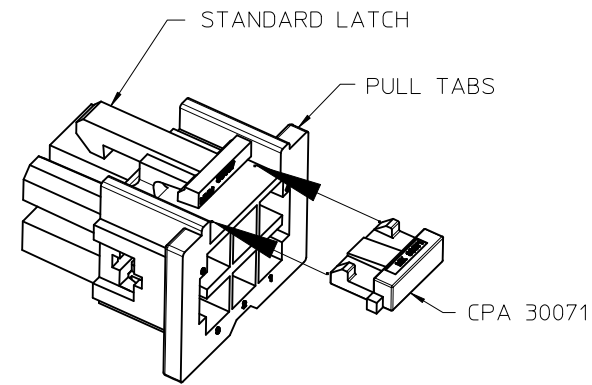

PART NO	ENG NO	COLOR:
15-97-0071	30071-0001	NATURAL
30071-0002	30071-0002	BLACK

ADD NOTE 4 EC NO: UCP2012-2732 DRWN: NGUYEN 2012/04/26 CHKD: APPR: FSMITH 2012/05/04 DESCRIPTION	H2	REV
---	----	-----

GENERAL TOLERANCES (UNLESS SPECIFIED)	
	mm INCH
4 PLACES	± --- ± ---
3 PLACES	± --- ± .010
2 PLACES	± 0.25 ± .014
1 PLACE	± 0.35 ± ---
ANGULAR ± 1/2°	
DRAFT WHERE APPLICABLE MUST REMAIN WITHIN DIMENSIONS	

DIMENSION STYLE IN/MM	
DRAWN BY KSAMIEC	DATE 2010/11/15
CHECKED BY	DATE
APPROVED BY JCOMERC I	DATE 2010/11/19
MATERIAL NO. SEE CHART	
SIZE A	

SCALE 4:1	DESIGN UNITS INCH	THIRD ANGLE PROJECTION
CONNECTOR POSITION ASSURANCE (CPA) FOR MINI-FIT T.P.A.		
MOLEX INCORPORATED		
MATERIAL NO. SD-30071-0000	DOCUMENT NO.	SHEET NO. 1 OF 1