

NOTES:

- 1) MATERIAL:
HOUSING: NYLON(IPA), GLASS FILLED, UL94V-0, COLOR: SEE CHART
TERMINALS: PHOSPHOR BRONZE
- 2) FINISH:
TERMINALS:
SELECT GOLD IN CONTACT AREA: 50 MICROINCHES (1.27 MICROMETERS) MIN.
SELECT TIN IN PC TAIL AREA: 100 MICROINCHES (2.54 MICROMETERS) MIN.,
WITH OVERALL NICKEL UNDERPLATE: 50 MICROINCHES (1.27 MICROMETERS) MIN.
- 3) PRODUCT SPECIFICATION: PS-43860-003.
- 4) PACKAGING SPECIFICATION:
CONNECTOR ASSEMBLIES PACKAGED IN EXTRUDED TUBES PER MOLEX
PACKAGING SPECIFICATION PK-43860-004.
- 5) ALL UNTOLERANCED DIMENSIONS ARE SHOWN FOR REFERENCE ONLY.
- 6) CONFORMS TO FCC REGULATION PART 68.5 FOR MODULAR JACKS.
- 7) THIS PART CONFORMS TO CLASS B REQUIREMENTS OF COSMETIC
SPECIFICATION PS-45499-002.

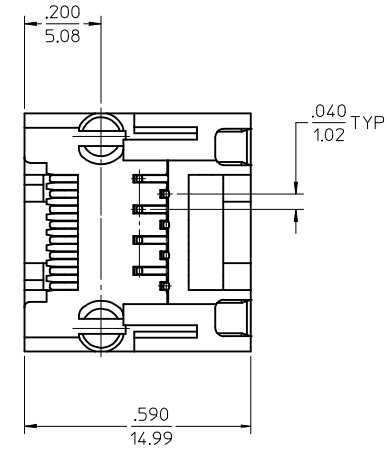
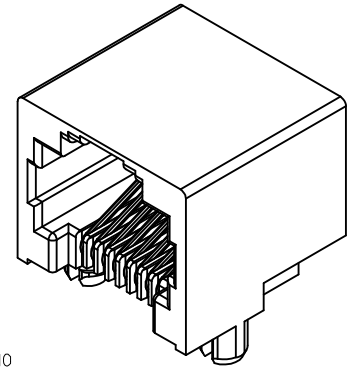
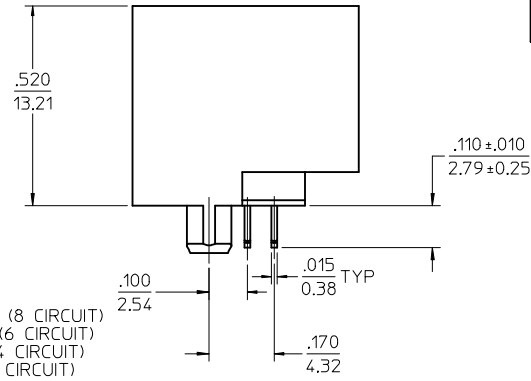
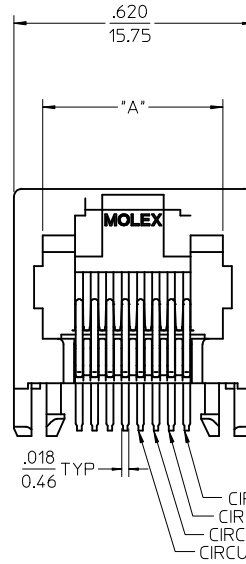
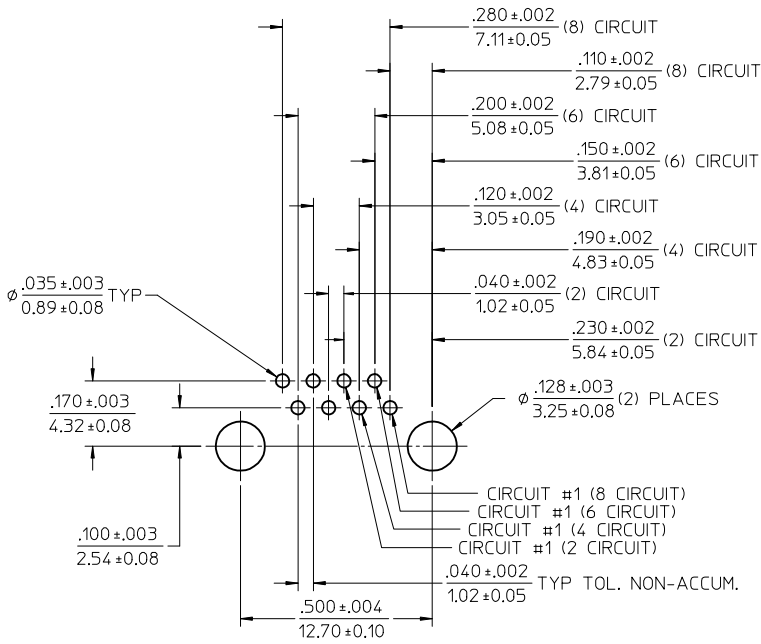

ASSEMBLY MAT. NUM.	CONNECTOR SIZE	DIM "A"	CIRCUITS	HOUSING COLOR
43860-0001	8	.469/11.91	8	BLACK
43860-0002	6	.389/9.88	6	BLACK
43860-0003	6	.389/9.88	4	BLACK
43860-0019	8	.469/11.91	4	BLACK
43860-0020	6	.389/9.88	2	BLACK

UPDATE VIEWS		QUALITY SYMBOLS	GENERAL TOLERANCES (UNLESS SPECIFIED)		DIMENSION STYLE		SCALE	DESIGN UNITS	THIRD ANGLE PROJECTION	
REV	DESCRIPTION		mm	INCH	IN/MM	DATE	INCH	TITLE	SHEET NO.	
H9	2015/05/19	▽=0	±	±	DRAWN BY	1997/02/13	4:1	INVERTED MODULAR JACK ASSEMBLY	1 OF 5	
	2014/08/25	▽=0	±0.25	±.010	CHECKED BY	1997/03/03				
	2014/08/25	▽=0	±	±	APPROVED BY	1997/03/04				
	2015/05/19	▽=0	±	±	MATERIAL NO.					
			ANGULAR ±1/2°		SEE CHART					
			DRAFT WHERE APPLICABLE MUST REMAIN WITHIN DIMENSIONS		DOCUMENT NO.					
					SD-43860-001					
					THIS DRAWING CONTAINS INFORMATION THAT IS PROPRIETARY TO MOLEX INCORPORATED AND SHOULD NOT BE USED WITHOUT WRITTEN PERMISSION					

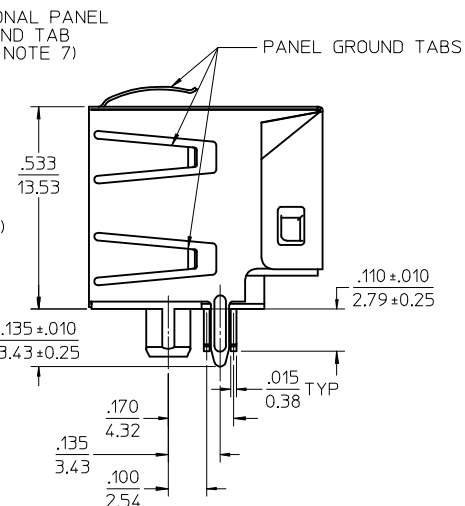
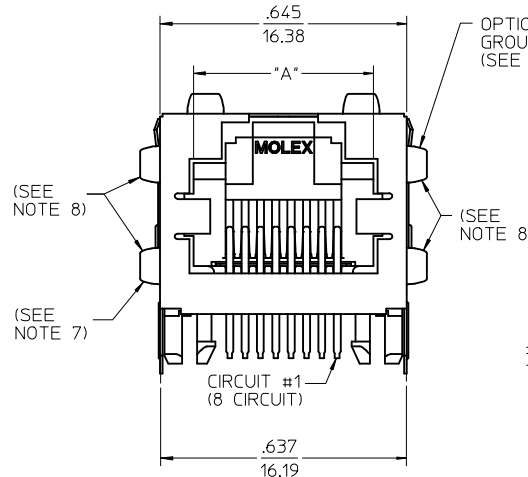
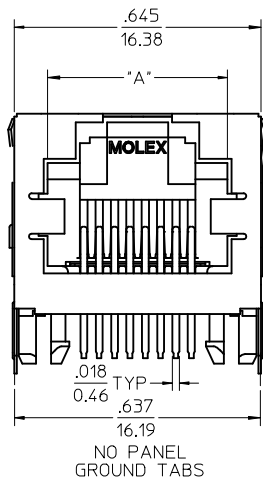
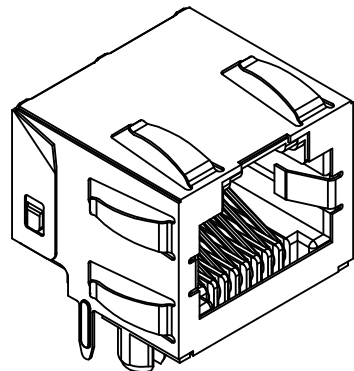

NOTES:

- 1) MATERIAL:
HOUSING: NYLON(PA), GLASS FILLED, UL94V-0,
COLOR: BLACK
TERMINALS: PHOSPHOR BRONZE
SHIELD: BRASS
- 2) FINISH:
TERMINALS:
SELECT GOLD IN CONTACT AREA: 50 MICROINCHES/
1.27 MICROMETERS MIN.,
SELECT TIN IN PC TAIL AREA: 100 MICROINCHES/
2.54 MICROMETERS MIN.,
WITH OVERALL NICKEL UNDERPLATE: 50 MICROINCHES/
1.27 MICROMETERS MIN.
SHIELD:
100 MICROINCHES/2.54 MICROMETERS NICKEL OVER
50 MICROINCHES/1.27 MICROMETERS COPPER
UNDERPLATE, PCB GROUND TABS DIPPED IN TIN
- 3) PRODUCT SPECIFICATION: PS-43860-003.
- 4) PACKAGING SPECIFICATION:
CONNECTOR ASSEMBLIES PACKAGED IN THERMOFORMED TRAYS
PER MOLEX PACKAGING SPECIFICATION PK-43860-005.
43860-5025 CONNECTOR ASSEMBLIES PACKAGED IN TAPE AND
REEL PER MOLEX PACKAGING SPECIFICATION PK-70873-700*
- 5) ALL UNTOLERANCED DIMENSIONS ARE SHOWN FOR REFERENCE ONLY.
- 6) CONFORMS TO FCC REGULATION PART 68.5 FOR MODULAR JACKS.
- 7) AVAILABLE WITH THE (2) SPECIFIED PANEL GROUND TABS
OMITTED FOR SIDE TO SIDE STACKABILITY, PER THE ASSEMBLY
MATERIAL NUMBER TABLE.
- 8) AVAILABLE WITH TOP PANEL GROUND TABS ONLY, PER THE
ASSEMBLY MATERIAL NUMBER TABLE.
- 9) THIS PART CONFORMS TO CLASS B REQUIREMENTS OF COSMETIC
SPECIFICATION PS-45499-002.

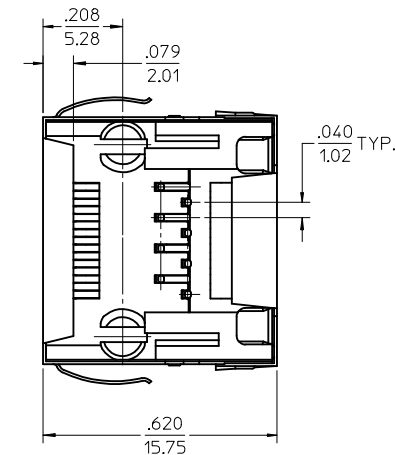
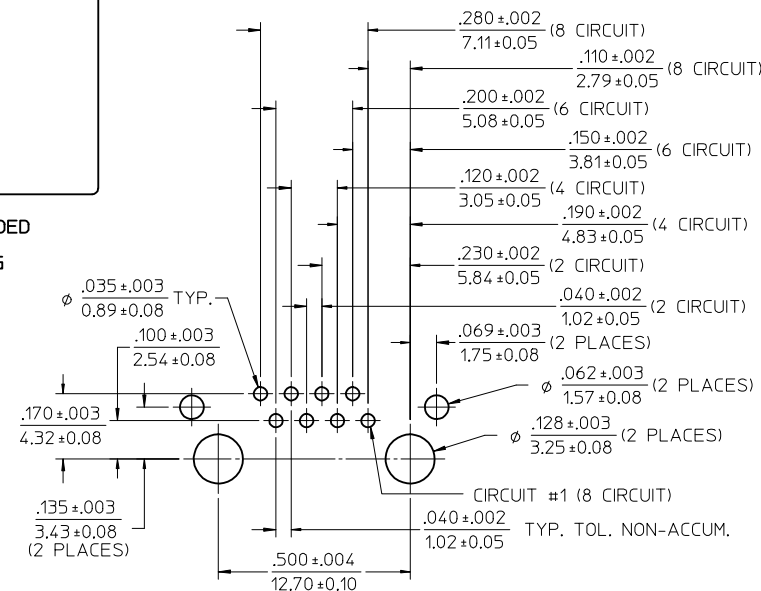
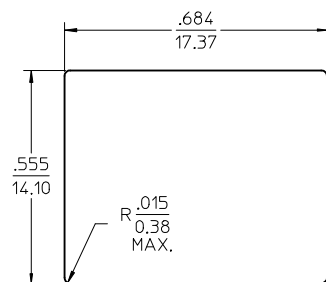

PC BOARD LAYOUT
COMPONENT SIDE OF BOARD
RECOMMENDED PCB THICKNESS .062±.005/1.57±.013

ASSEMBLY MAT. NUM.	CONNECTOR SIZE	DIM "A"	CIRCUITS	PANEL GROUND TABS	PACKAGING OPTION
43860-0004	8	.469/11.91	8	ALL	TRAY
43860-0005	6	.389/9.88	6	ALL	TRAY
43860-0006	6	.389/9.88	4	ALL	TRAY
43860-0013	8	.469/11.91	8	SEE NOTE #7	TRAY
43860-0014	6	.389/9.88	6	SEE NOTE #7	TRAY
43860-0015	6	.389/9.88	4	SEE NOTE #7	TRAY
43860-0024	6	.389/9.88	2	ALL	TRAY
43860-0025	8	.469/11.91	8	NONE	TRAY
43860-0026	6	.389/9.88	6	NONE	TRAY
43860-0027	6	.389/9.88	4	NONE	TRAY
43860-0031	8	.469/11.91	8	SEE NOTE #8	TRAY
43860-5025	8	.469/11.91	8	NONE	TAPE

SEE SHEET 1 EC NO: UCP2015-0148 DRAWING: NGUYEN 2014/08/25 CHKD: J.BELL 2014/08/25 APPR: F.S.MITH 2015/05/19 H9	QUALITY SYMBOLS ∇=0 ∇=0 ∇=0	GENERAL TOLERANCES (UNLESS SPECIFIED)		DIMENSION STYLE IN/MM		SCALE 4:1	DESIGN UNITS INCH	THIRD ANGLE PROJECTION		
		4 PLACES ± --- ± --- 3 PLACES ± --- ±.010 2 PLACES ± 0.25 ± --- 1 PLACE ± --- ± --- 0 PLACE ± ±		DRAWN BY TALEND		DATE 1997/02/13	TITLE INVERTED MODULAR JACK ASSEMBLY			
		ANGULAR ±1/2°		CHECKED BY ROBERTS		DATE 1997/03/03	MATERIAL NO. SEE CHART			
		DRAFT WHERE APPLICABLE MUST REMAIN WITHIN DIMENSIONS		APPROVED BY FRY		DATE 1997/03/04	DOCUMENT NO. SD-43860-001		SHEET NO. 2 OF 5	

THIS DRAWING CONTAINS INFORMATION THAT IS PROPRIETARY TO MOLEX INCORPORATED AND SHOULD NOT BE USED WITHOUT WRITTEN PERMISSION

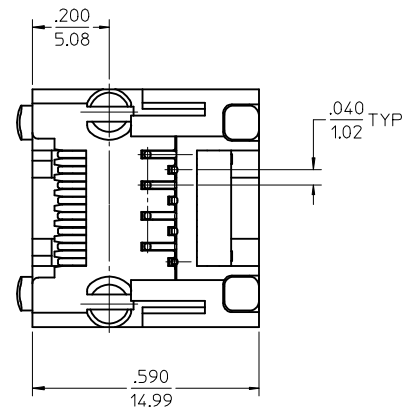
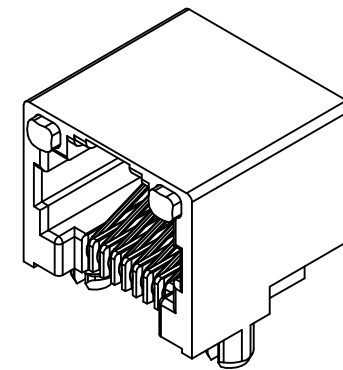
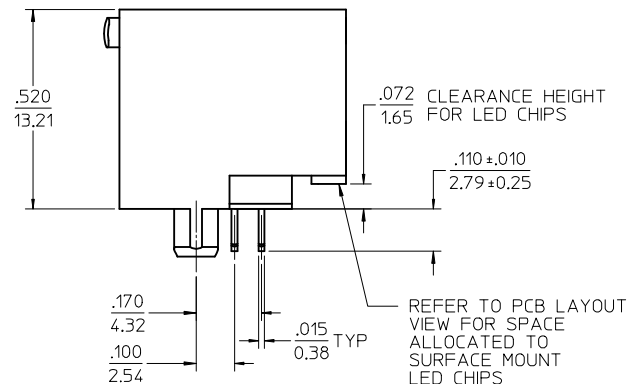
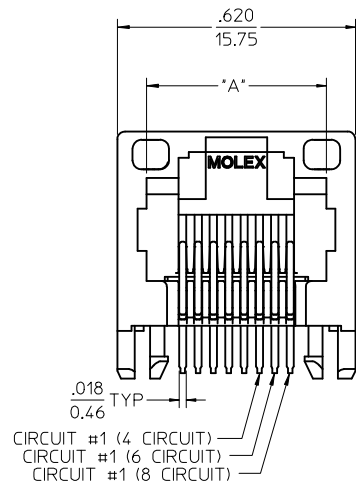

NOTES:

- 1) MATERIAL:
 HOUSING: NYLON(PA), GLASS FILLED, UL94V-0, COLOR: BLACK
 TERMINALS: PHOSPHOR BRONZE
 LIGHT PIPES:
 POLYCARBONATE - WAVE OR HAND SOLDER ONLY
 (NOT DESIGNED FOR I/R REFLOW OR CONVECTION REFLOW SOLDER PROCESSES)
 POLYSULFONE - MAXIMUM REFLOW TEMPERATURE 400°F (205°C)
- 2) FINISH:
 TERMINALS:
 SELECT GOLD IN CONTACT AREA: 50 MICROINCHES (1.27 MICROMETERS) MIN.,
 SELECT TIN IN PC TAIL AREA: 100 MICROINCHES (2.54 MICROMETERS) MIN.,
 WITH OVERALL NICKEL UNDERPLATE: 50 MICROINCHES (1.27 MICROMETERS) MIN.
- 3) PRODUCT SPECIFICATION AND PROCESSING PARAMETERS: PS-43860-003.
- 4) PACKAGING SPECIFICATION:
 CONNECTOR ASSEMBLIES PACKAGED IN EXTRUDED TUBES PER MOLEX PACKAGING SPECIFICATION PK-43860-004.
- 5) APPLICATION SPECIFICATION: AS-43860-001
- 6) ALL UNTOLERANCED DIMENSIONS ARE SHOWN FOR REFERENCE ONLY.
- 7) CONFORMS TO FCC REGULATION PART 68.5 FOR MODULAR JACKS.
- 8) REFER TO SHEET (5) OF (5) FOR RECOMMENDED PCB LAYOUT.
- 9) THIS PART CONFORMS TO CLASS B REQUIREMENTS OF COSMETIC SPECIFICATION PS-45499-002.

ASSEMBLY MAT. NUM.	LIGHT PIPE MATERIAL	CONNECTOR SIZE	DIM "A"	CIRCUITS
43860-0007	POLYCARBONATE	8	.469/11.91	8
43860-0008	POLYCARBONATE	6	.389/9.88	6
43860-0009	POLYCARBONATE	6	.389/9.88	4
43860-0021	POLYSULFONE	8	.469/11.91	8
43860-0022	POLYSULFONE	6	.389/9.88	6
43860-0023	POLYSULFONE	6	.389/9.88	4

SEE SHEET 1 EC NO: UCP2015-0148 DRAWN: NGUYEN CHKD: BELL APPR: F. SMITH	2014/08/25 2014/08/25 2015/05/19	QUALITY SYMBOLS ∇=0 ∇=0 ∇=0	GENERAL TOLERANCES (UNLESS SPECIFIED)		DIMENSION STYLE	SCALE	DESIGN UNITS	THIRD ANGLE PROJECTION					
					IN/MM	4:1	INCH	TITLE					
					mm	INCH	DRAWN BY		DATE	INVERTED MODULAR JACK ASSEMBLY			
							TALEND	1997/02/13					
				CHECKED BY		DATE	molex						
				ROBERTS	1997/03/03								
				APPROVED BY		DATE	SD-43860-001						
				FRY	1997/03/04								
				MATERIAL NO.		DOCUMENT NO.	SHEET NO.						
				SEE CHART		SD-43860-001					3 OF 5		
				DRAFT WHERE APPLICABLE MUST REMAIN WITHIN DIMENSIONS		SIZE		THIS DRAWING CONTAINS INFORMATION THAT IS PROPRIETARY TO MOLEX INCORPORATED AND SHOULD NOT BE USED WITHOUT WRITTEN PERMISSION					

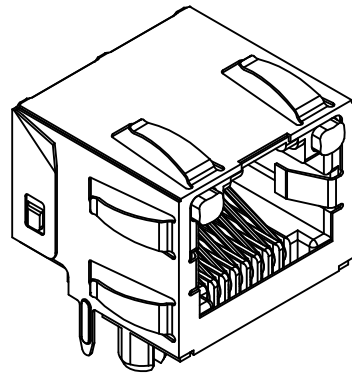

OPTIONAL PANEL GROUND TAB (SEE NOTE 8)

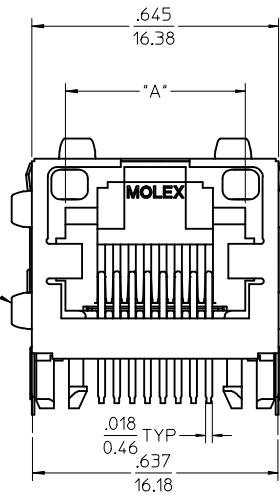

OPTIONAL PANEL GROUND TAB (SEE NOTE 8)

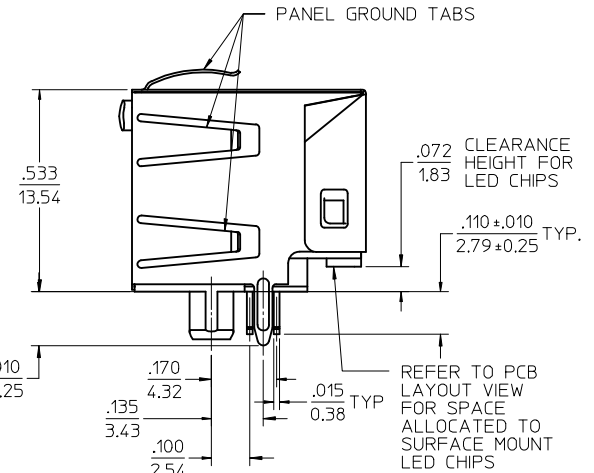

REFER TO PCB LAYOUT VIEW FOR SPACE ALLOCATED TO SURFACE MOUNT LED CHIPS

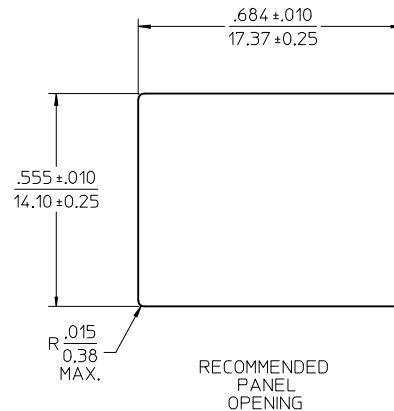

RECOMMENDED PANEL OPENING

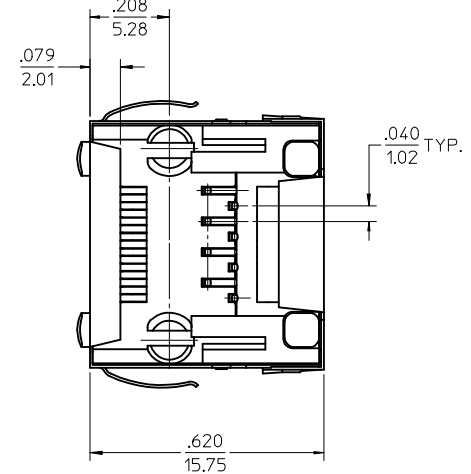

NOTES:

- 1) MATERIAL:
HOUSING: NYLON(PA), GLASS FILLED, UL94V-0, COLOR: BLACK
TERMINALS: PHOSPHOR BRONZE
SHIELD: BRASS
LIGHT PIPES:
POLYCARBONATE - WAVE OR HAND SOLDER ONLY (NOT DESIGNED FOR I/R REFLOW OR CONVECTION REFLOW SOLDER PROCESSES)
POLYSULFONE - MAXIMUM REFLOW TEMPERATURE 400°F (205°C)
- 2) FINISH:
TERMINALS:
SELECT GOLD IN CONTACT AREA: 50 MICROINCHES/1.27 MICROMETERS MIN.
SELECT TIN IN PC TAIL AREA: 100 MICROINCHES/2.54 MICROMETERS MIN.
WITH OVERALL NICKEL UNDERPLATE: 50 MICROINCHES/1.27 MICROMETERS MIN.
SHIELD:
100 MICROINCHES/2.54 MICROMETERS OVER 50 MICROINCHES/1.27 MICROMETERS COPPER UNDERPLATE, PCB GROUND TABS DIPPED IN TIN
- 3) PRODUCT SPECIFICATION AND PROCESSING PARAMETERS: PS-43860-003.
- 4) PACKAGING SPECIFICATION:
CONNECTOR ASSEMBLIES PACKAGED IN THERMOFORMED TRAYS PER MOLEX PACKAGING SPECIFICATION PK-43860-005.
- 5) APPLICATION SPECIFICATION: AS-43860-001
- 6) ALL UNTOLERANCED DIMENSIONS ARE SHOWN FOR REFERENCE ONLY.
- 7) CONFORMS TO FCC REGULATION PART 68.5 FOR MODULAR JACKS.
- 8) AVAILABLE WITH THE (2) SPECIFIED PANEL GROUND TABS OMITTED FOR SIDE TO SIDE STACKABILITY, PER THE ASSEMBLY MATERIAL NUMBER TABLE.
- 9) REFER TO SHEET (5) OF (5) FOR RECOMMENDED PCB LAYOUT.
- 10) THIS PART CONFORMS TO CLASS B REQUIREMENTS OF COSMETIC SPECIFICATION PS-45499-002.

ASSEMBLY MAT. NUM.	LIGHT PIPE MATERIAL	CONNECTOR SIZE	DIM "A"	CIRCUITS	PANEL GROUND TABS
43860-0010	POLYCARBONATE	8	.469/11.91	8	ALL
43860-0011	POLYCARBONATE	6	.389/9.88	6	ALL
43860-0012	POLYCARBONATE	6	.389/9.88	4	ALL
43860-0016	POLYCARBONATE	8	.469/11.91	8	SEE NOTE #8
43860-0017	POLYCARBONATE	6	.389/9.88	6	SEE NOTE #8
43860-0018	POLYCARBONATE	6	.389/9.88	4	SEE NOTE #8
43860-1010	POLYSULFONE	8	.469/11.91	8	ALL
43860-1011	POLYSULFONE	6	.389/9.88	6	ALL
43860-1012	POLYSULFONE	6	.389/9.88	4	ALL
43860-1016	POLYSULFONE	8	.469/11.91	8	SEE NOTE #8
43860-1017	POLYSULFONE	6	.389/9.88	6	SEE NOTE #8
43860-1018	POLYSULFONE	6	.389/9.88	4	SEE NOTE #8

SEE SHEET 1 EC NO: UCP2015-0148 DRAWN: NGUYEN 2014/08/25 CHKD: BELL 2014/08/25 APPR: FSMITH 2015/05/19 H9	QUALITY SYMBOLS ∇=0 ∇=0 ∇=0	GENERAL TOLERANCES (UNLESS SPECIFIED) <table border="1"> <tr> <th></th> <th>mm</th> <th>INCH</th> </tr> <tr> <td>4 PLACES ±</td> <td>---</td> <td>±---</td> </tr> <tr> <td>3 PLACES ±</td> <td>---</td> <td>±.010</td> </tr> <tr> <td>2 PLACES ±</td> <td>0.25</td> <td>±---</td> </tr> <tr> <td>1 PLACE ±</td> <td>---</td> <td>±---</td> </tr> <tr> <td>0 PLACE ±</td> <td>±</td> <td>±</td> </tr> </table>		mm	INCH	4 PLACES ±	---	±---	3 PLACES ±	---	±.010	2 PLACES ±	0.25	±---	1 PLACE ±	---	±---	0 PLACE ±	±	±	DIMENSION STYLE IN/MM	SCALE 4:1	DESIGN UNITS INCH	THIRD ANGLE PROJECTION
		mm	INCH																					
	4 PLACES ±	---	±---																					
	3 PLACES ±	---	±.010																					
2 PLACES ±	0.25	±---																						
1 PLACE ±	---	±---																						
0 PLACE ±	±	±																						
DRAFT WHERE APPLICABLE MUST REMAIN WITHIN DIMENSIONS		MATERIAL NO. SEE CHART	DRAWN BY TALEND	DATE 1997/02/13	TITLE INVERTED MODULAR JACK ASSEMBLY																			
		ANGULAR ±1/2°	CHECKED BY ROBERTS	DATE 1997/03/03	molex																			
		SIZE C	APPROVED BY FRY	DATE 1997/03/04	DOCUMENT NO. SD-43860-001	SHEET NO. 4 OF 5																		

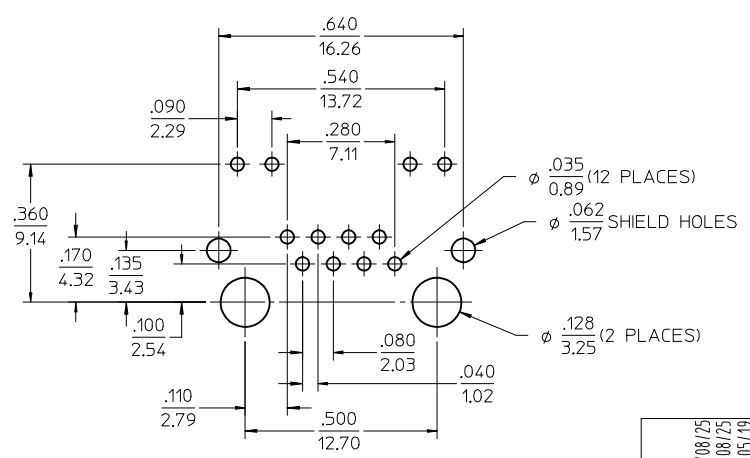
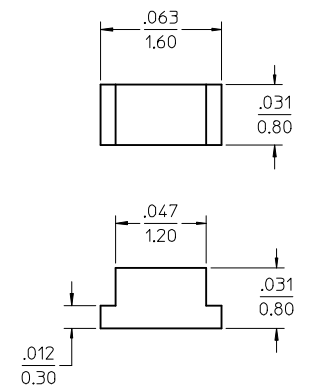
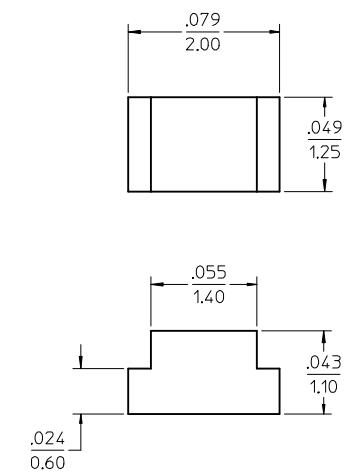
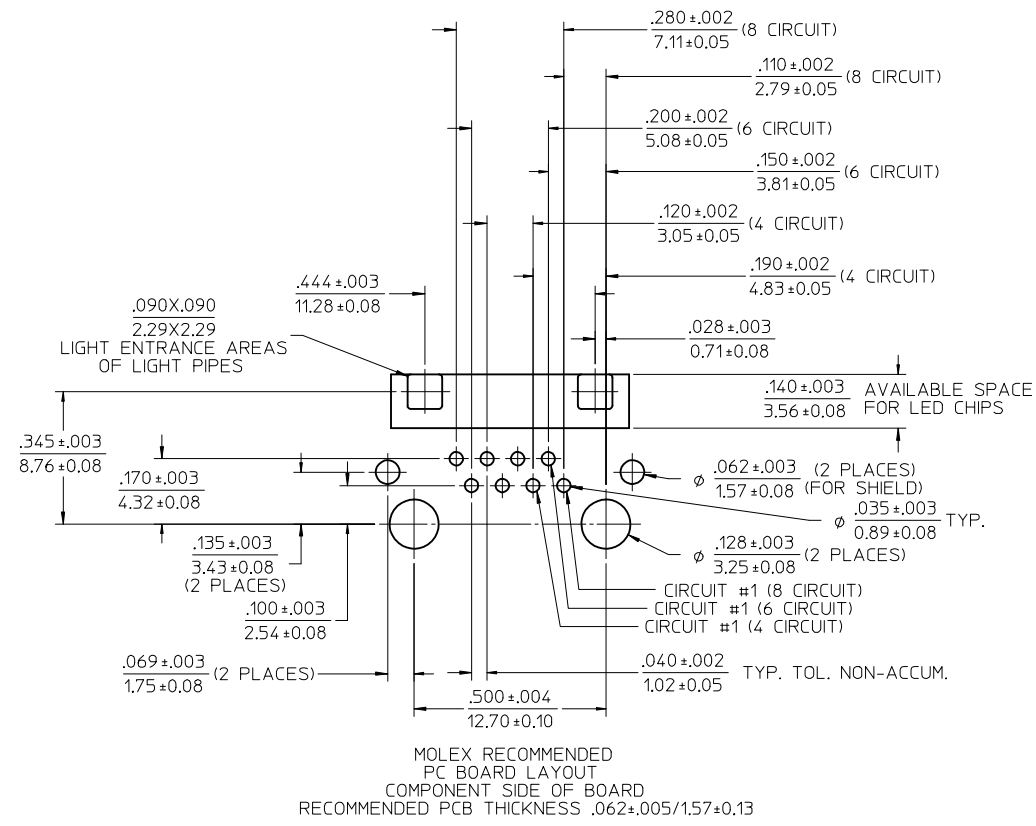

NOTES:
1. FOR CROSS REFERENCE OF RECOMMENDED LED'S SEE MOLEX WEB SITE

SEE SHEET 1 EC NO: UCP2015-0148 DRAWN: NGUYEN 2014/08/25 CHKD: JHELL 2014/08/25 APPR: F SMITH 2015/05/19 H9	QUALITY SYMBOLS ▽=0 ▽=0 ▽=0	GENERAL TOLERANCES (UNLESS SPECIFIED)	DIMENSION STYLE IN/MM	SCALE 4:1	DESIGN UNITS INCH	THIRD ANGLE PROJECTION
		4 PLACES ± --- ± --- 3 PLACES ± --- ± .010 2 PLACES ± .25 ± --- 1 PLACE ± --- ± --- 0 PLACE ± ±	DRAWN BY DATE TALEND 1997/02/13 CHECKED BY DATE ROBERTS 1997/03/03 APPROVED BY DATE FRY 1997/03/04	TITLE INVERTED MODULAR JACK ASSEMBLY		
		ANGULAR ±1/2°	MATERIAL NO. SEE CHART	DOCUMENT NO. SD-43860-001	SHEET NO. 5 OF 5	
		DRAFT WHERE APPLICABLE MUST REMAIN WITHIN DIMENSIONS				

THIS DRAWING CONTAINS INFORMATION THAT IS PROPRIETARY TO MOLEX INCORPORATED AND SHOULD NOT BE USED WITHOUT WRITTEN PERMISSION