

HOUSING MATERIAL: 94V-0 UNFILLED POLYESTER  
COLOR: WHITE

TERMINAL MATERIAL: PHOSPHOR BRONZE

SEE NOTE 10

SECTION A-A

SECTION B-B

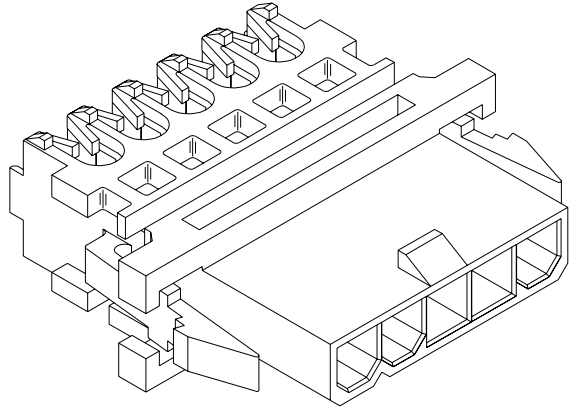

**NOTES:**

- ASSEMBLY NO. 71690-23\*\* SHOWN FOR ILLUSTRATION.
- MATES WITH PART NUMBER 71694-\*\*\*\*.
- SEE SHEET 2 FOR PART NUMBERS AND THEIR CONFIGURATIONS.
- FINISHES (SEE CHART):  
TIN OVERALL - .000100/(0.00254) MINIMUM TIN OVERALL, OVER NICKEL UNDERPLATING OVERALL.  
15 GOLD - .000015/(0.00038) MINIMUM SELECT GOLD AND .000150/(0.00380) MINIMUM SELECT TIN OVER NICKEL UNDERPLATING OVERALL.
- ITEM NUMBERS PRECEDED BY AN "X" IN THE CHART ARE NOT AVAILABLE.
- RECOMMENDED FOR USE WITH UL # 1007 STYLE WIRE.
- OPTIONAL COVER NUMBERS: 71161-\*\*\*01 (FEED THRU) OR ---02 (FEED TO VERSION).
- SEE SHEET 7 FOR PANEL CUTOUT DETAIL.
- PART CONFORMS TO SPECIFICATION NO. PS-71690-001.
- RECYCLE LOGO: >PBT< FR TO BE LOCATED IN THIS AREA.
- IDT SLOT IDENTIFIER COLOR STRIPE TO BE LOCATED ON THIS SURFACE. ID PER CHART BELOW.

WIRE GAUGE	ID COLOR
18	FLRSCNT MAGENTA
20	BLUE
22	GREEN
24	BLACK

- SEE SMES-71690-0000 FOR TERMINATION SPECIFICATIONS.
- PACKAGE PER PK-71690-0000.

NOTE FOR LEAD FREE CONVERSION:

THE PRIMARY SHIPPING CARTON WILL BE LABELED "COMPLIANT TO ROHS DIRECTIVE 2002/95/EC AND ELV ANNEX II OF DIRECTIVE 2000/53/EC". CARTONS WITHOUT THIS LABEL MAY CONTAIN PRODUCT WITH LEAD.

L	LEAD FREE CONV ECN UCP2004-2042 ADAMS 04/04/20
K	CHANGE PROD SPEC ECR UDT2001-0195 KMS 9/22/2000
J	ALL WHITE MAT'L PER EC # U71026 ELO 97/2/26
I	18 AWG CLR CHANGE PER ECR U70413 ELO 10/23/96
H	REVISED PER ECR U61437 PAR 05/15/96
G	REVISED PER ECR U61185 TSE 03/27/96
F	ADD GOLD ASSY'S PER ECR U51189 08/30/95 sds
E	REV CHARTS/D DIM PER ECR U60094 07/26/95 sds
8	J D ADD HOLE/NOTE 12 PER ECR U50939 04/17/95 sds
7	L C ADD DIM/REV NOTE PER ECR U40914 8/10/94 sds
6	L C ADD NOTE II PER ECR U40717 6/29/94 sds
4	L B FINAL RELEASE PER ECR U40514 4/25/94 sds
2	L A
1	L A

MFG, SH, REV, LTR, REVISIONS

DIMENSIONS SHOWN (METRIC) INCH	
UNLESS OTHERWISE SPECIFIED TOLERANCES: ANGULAR ± 1/2°	
3 PLACE	± .010
2 PLACE	± .014 ± 0.25
1 PLACE	± 0.36

REVISIONS ONLY ON CAD SYSTEM

TITLE: MINI-FIT IDT SINGLE ROW PLUG SALES ASSEMBLY

MOLEX INCORPORATED SHEET NO. DATE U.S.A. 1 OF 8 01/28/93

MOLEX INC. 60532

SEE CHART SDA-71690-\*\*\*\*

DRWG. NO. 4: 1

FILE NAME: 571690X1.DEN

THIS DRAWING CONTAINS INFORMATION THAT IS PROPRIETARY TO MOLEX INC. AND SHOULD NOT BE USED WITHOUT WRITTEN PERMISSION.

71690

J	CKT SIZE	S T A T	ASSEMBLY ITEM NUMBER	PANEL MOUNTS	WIRE AWG	WIRE DESCRIPTION	DIMENSION A		DIMENSION B		DIMENSION C		PLATING SEE NOTE 4
							INCH	(MM)	INCH	(MM)	INCH	(MM)	
	2		71690-1001	NO	18	SOLID,FUSED STRANDED,STRANDED	0.490	(12.45)	0.378	(9.60)	0.1654	(4.20)	TIN OVERALL
	2		71690-1003	NO	20		0.490	(12.45)	0.378	(9.60)	0.1654	(4.20)	
	2		71690-1004	NO	22		0.490	(12.45)	0.378	(9.60)	0.1654	(4.20)	TIN OVERALL
	2		71690-1005	NO	24		0.490	(12.45)	0.378	(9.60)	0.1654	(4.20)	
	2		71690-1007	NO	18		0.490	(12.45)	0.378	(9.60)	0.1654	(4.20)	I5 GOLD
	2		71690-1009	NO	20		0.490	(12.45)	0.378	(9.60)	0.1654	(4.20)	
	2		71690-1010	NO	22		0.490	(12.45)	0.378	(9.60)	0.1654	(4.20)	I5 GOLD
	2		71690-1011	NO	24		0.490	(12.45)	0.378	(9.60)	0.1654	(4.20)	
	2		71690-1101	YES	18		0.821	(20.48)	0.378	(9.60)	0.1654	(4.20)	TIN OVERALL
	2		71690-1103	YES	20		0.821	(20.48)	0.378	(9.60)	0.1654	(4.20)	
	2		71690-1104	YES	22		0.821	(20.48)	0.378	(9.60)	0.1654	(4.20)	I5 GOLD
	2		71690-1105	YES	24		0.821	(20.48)	0.378	(9.60)	0.1654	(4.20)	
	2		71690-1107	YES	18		0.821	(20.48)	0.378	(9.60)	0.1654	(4.20)	I5 GOLD
	2		71690-1109	YES	20		0.821	(20.48)	0.378	(9.60)	0.1654	(4.20)	
	2		71690-1110	YES	22		0.821	(20.48)	0.378	(9.60)	0.1654	(4.20)	TIN OVERALL
	2		71690-1111	YES	24		0.821	(20.48)	0.378	(9.60)	0.1654	(4.20)	
	3		71690-1401	NO	18		0.655	(16.65)	0.543	(13.80)	0.3307	(8.40)	I5 GOLD
	3		71690-1403	NO	20		0.655	(16.65)	0.543	(13.80)	0.3307	(8.40)	
	3		71690-1404	NO	22		0.655	(16.65)	0.543	(13.80)	0.3307	(8.40)	TIN OVERALL
	3		71690-1405	NO	24		0.655	(16.65)	0.543	(13.80)	0.3307	(8.40)	
	3		71690-1407	NO	18		0.655	(16.65)	0.543	(13.80)	0.3307	(8.40)	I5 GOLD
	3		71690-1409	NO	20		0.655	(16.65)	0.543	(13.80)	0.3307	(8.40)	
	3		71690-1410	NO	22		0.655	(16.65)	0.543	(13.80)	0.3307	(8.40)	TIN OVERALL
	3		71690-1411	NO	24		0.655	(16.65)	0.543	(13.80)	0.3307	(8.40)	
	3		71690-1501	YES	18		0.986	(25.05)	0.543	(13.80)	0.3307	(8.40)	I5 GOLD
	3		71690-1503	YES	20		0.986	(25.05)	0.543	(13.80)	0.3307	(8.40)	
	3		71690-1504	YES	22		0.986	(25.05)	0.543	(13.80)	0.3307	(8.40)	TIN OVERALL
	3		71690-1505	YES	24		0.986	(25.05)	0.543	(13.80)	0.3307	(8.40)	
	3		71690-1507	YES	18		0.986	(25.05)	0.543	(13.80)	0.3307	(8.40)	I5 GOLD
	3		71690-1509	YES	20		0.986	(25.05)	0.543	(13.80)	0.3307	(8.40)	
	3		71690-1510	YES	22		0.986	(25.05)	0.543	(13.80)	0.3307	(8.40)	TIN OVERALL
	3		71690-1511	YES	24	SOLID,FUSED STRANDED,STRANDED	0.986	(25.05)	0.543	(13.80)	0.3307	(8.40)	

WITHOUT PANEL MOUNTS

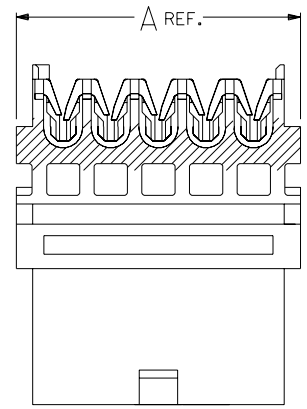

L	SEE SHEET I
H	SEE SHEET I
F	SEE SHEET I
D	SEE SHEET I
C	SEE SHEET I
A	SEE SHEET I
4	SEE SHEET I
3	SEE SHEET I
2	SEE SHEET I
I	SEE SHEET I

71690

POLARIZATION SCHEME

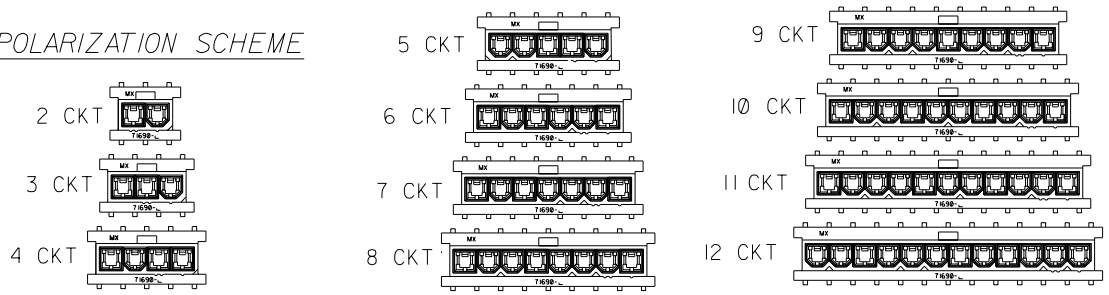

DIMENSIONS SHOWN (METRIC) INCH		REVISIONS	
UNLESS OTHERWISE SPECIFIED TOLERANCES: ANGULAR ± 1/2°		MFG. SH.	REV.
5 PLACE ± .010	METRIC ---	LTR.	REV. ONLY ON CAD SYSTEM
2 PLACE ± .014	± 0.25	TITLE	
1 PLACE ---	± 0.36	MINI-FIT IDT SINGLE ROW PLUG ASSEMBLY	
DRAFT WHERE APPLICABLE MUST REMAIN WITHIN DIMENSIONS		PROB. MOLEX INCORPORATED	SHEET NO. 2
DATE 01/28/93		U.S.A.	68532
DRWG. NO. SDA-71690-****	DRWG. NO. SDA-71690-****	FILE NAME	DIV.
BY RWB	CHK'D. BY SAS	71690X2	TC
APP'D. BY	SCALE	THIS DRAWING CONTAINS INFORMATION THAT IS PROPRIETARY TO MOLEX INC. AND SHOULD NOT BE USED WITHOUT WRITTEN PERMISSION.	





**MOLEX INCORPORATED**  
LISLE, ILL. 60532 U.S.A.

## WIRE TERMINATION SPECIFICATION

### 1.0 APPLICABLE DRAWINGS:

THIS SPECIFICATION APPLIES TO A-71690 AND A-71694 SERIES OF INSULATION DISPLACEMENT CONNECTORS.

### 2.0 SCOPE:

THIS SPECIFICATION IS DESIGNED TO INSURE THE PROPER TERMINATION AND PERFORMANCE OF THE A-71690 AND A-71694 SERIES OF INSULATION DISPLACEMENT CONNECTORS.

### 3.0 GENERAL:

THE .1654/(4.20) CENTER INSULATION DISPLACEMENT CONNECTOR SYSTEM IS DESIGNED TO INTERCONNECT DISCRETE WIRE AS OUTLINED IN THIS SPECIFICATION.

### 4.0 CONDUCTOR REQUIREMENTS:

#### 4.1 CONDUCTOR SIZE IDENTIFICATION:

CONDUCTOR SIZE	CONDUCTOR STYLE	HOUSING ID COLOR (SEE FIG. 4)	TERMINAL ID HOLE POSITION (SEE FIG.8; SHT.5)
18 AWG	STRANDED WITH TOPCOAT,FUSED, SOLID	RED	POSITION 1
20 AWG	STRANDED WITH TOPCOAT,FUSED, SOLID	BLUE	POSITION 2
22 AWG	STRANDED WITH TOPCOAT,FUSED, SOLID	GREEN	POSITION 3
24 AWG	STRANDED WITH TOPCOAT,FUSED, SOLID	BLACK	POSITION 4

RECOMMENDED UL STYLE: 1007, 1061

#### 4.2 INSULATION REQUIREMENTS:

INSULATION DIAMETER: .090 MAX

INSULATION HARDNESS: 85 MAX ON THE SHORE A SCALE

### 5.0 TERMINATION REQUIREMENTS:

#### 5.1 CABLE INSERTION DEPTH:

THE CABLE SHOULD BE INSERTED TO DEPTH OF .140/(3.56)\* FROM THE TOP OF THE HOUSING TO THE TOP OF THE WIRE (SEE FIGURE 2). WIRE MUST BE LOCATED BELOW THE BOTTOM OF EAGLES.

\* TERMINATION DEPTH FOR THE 24 AWG WIRES IN THE FOLLOWING ASSEMBLIES TO BE .138±.005/(3.51±0.13); 71690-6008 AND 71694-2402.

STRAIN RELIEF

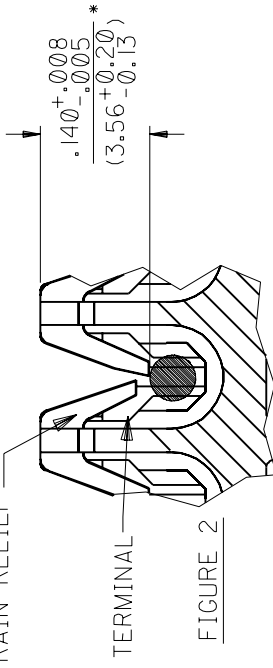

FIGURE 2

REV.	B	A	B	B	B
SHT.	1	2	3	4	5

FILE NAME  
T71690X1

▽ = 0      ◀ = 0

REVISE ONLY ON CAD SYSTEM

REV. B

THIS DRAWING CONTAINS INFORMATION THAT IS PROPRIETARY TO MOLEX INC. AND SHOULD NOT BE USED WITHOUT WRITTEN PERMISSION.

SHT. 1 OF 5

DRWG. NO. SMES-71690-0000

DRWG. NO. SMES-71690-0000



## WIRE TERMINATION SPECIFICATION

### 5.2 WIRE CUT OFF

IN THE FEED-TO VERSION THE WIRE MUST BE DISPLACED IN BOTH INSULATION DISPLACEMENT SLOTS AND MUST PROTRUDE THROUGH THE SECONDARY SLOT BY  $(1.52)/(.060)$  MIN. AS SHOWN IN FIGURE 3.

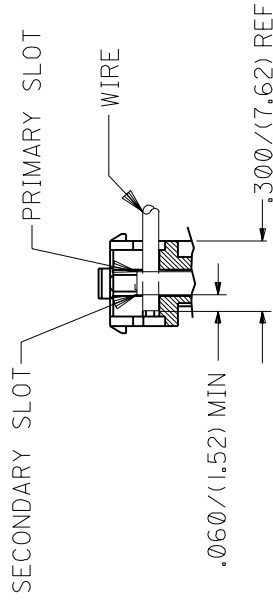

FIGURE 3

### 5.3 HORIZONTAL PULL OUT FORCE

THE CONNECTOR MUST MAINTAIN THE FOLLOWING MIN. PULL OUT VALUES WHEN A FORCE IS APPLIED AT A RATE OF 1 INCH PER MINUTE TO THE CABLE IN A DIRECTION PERPENDICULAR TO THE INSULATION DISPLACEMENT SECTION. AS SHOWN IN FIGURE 4. (NOTE CABLE MUST BE SLIT TO FORM INDIVIDUAL CONDUCTORS AFTER TERMINATION BUT PRIOR TO TESTING).

AWG	PULL FORCE
18 AWG	14.0 LBS. MIN.
20 AWG	TBD
22 AWG	TBD
24 AWG	8.0 LBS. MIN.

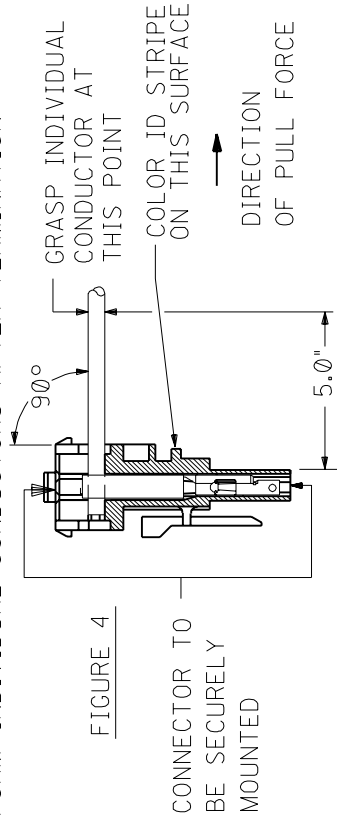

FIGURE 4

### 5.4 VERTICAL PULL OUT FORCE

THE CONNECTOR MUST MAINTAIN THE FOLLOWING MIN. PULL OUT VALUES WHEN A FORCE IS APPLIED AT A RATE OF 1 INCH PER MINUTE TO THE CABLE IN A DIRECTION PARALLEL TO THE INSULATION DISPLACEMENT SECTION. AS SHOWN IN FIGURE 5. (NOTE CABLE MUST BE SLIT TO FORM INDIVIDUAL CONDUCTORS AFTER TERMINATION BUT PRIOR TO TESTING).

AWG	PULL FORCE
18 AWG	5.0 LBS. MIN.
20 AWG	TBD
22 AWG	TBD
24 AWG	2.4 LBS. MIN.

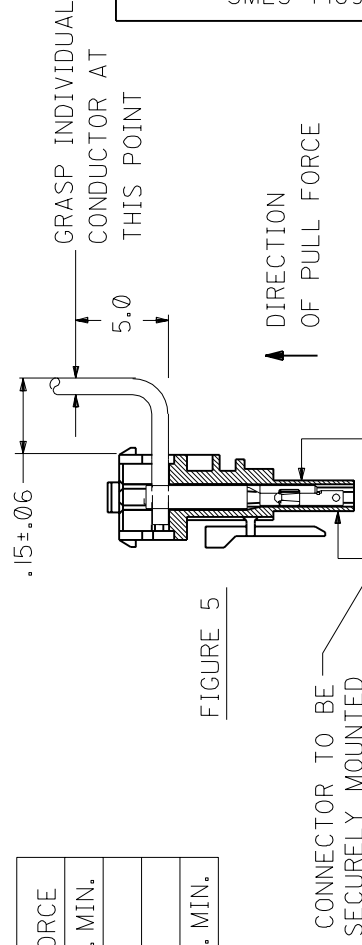

FIGURE 5

REV.

SHT.

FILE NAME  
T71690X2

▽ C = 0

▲ = 0

CONNECTOR TO BE SECURELY MOUNTED

REVISE ONLY ON CAD SYSTEM

REV.

A

THIS DRAWING CONTAINS INFORMATION THAT IS PROPRIETARY TO MOLEX INC. AND SHOULD NOT BE USED WITHOUT WRITTEN PERMISSION.

SHT.

2



**MOLEX INCORPORATED**  
LISLE, ILL. 60532 U.S.A.

## WIRE TERMINATION SPECIFICATION

### 5.5 TORSIONAL RESISTANCE:

CONNECTOR MUST WITHSTAND A MAXIMUM TWIST ON A TERMINATED CABLE OF 130° WITHOUT DISTURBING THE INSULATION DISPLACEMENT INTERFACE IN THE PRIMARY OR SECONDARY SLOTS (SEE FIGURE 3) (NOTE CABLE MUST BE SLIT TO FORM INDIVIDUAL CONDUCTORS AFTER TERMINATION BUT PRIOR TO TESTING).

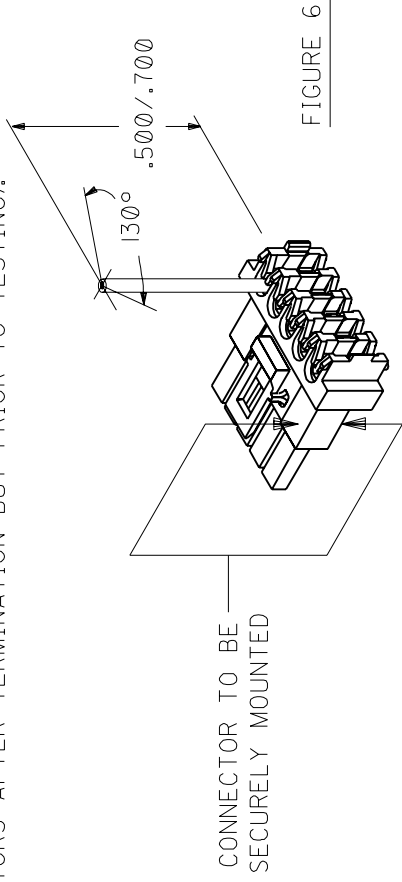

### 5.6 VISUAL INSPECTION:

AFTER TERMINATION, INSULATION DISPLACEMENT SECTION OF THE TERMINAL TO BE FREE OF TOOL MARKS FROM TERMINATION EQUIPMENT.

### 6.0 TERMINATION EVALUATION PROCEDURE:

STEP 1 - STRAIN RELIEF REMOVAL  
REMOVE SHADED PORTION OF THE STRAIN RELIEF USING A RAZOR BLADE

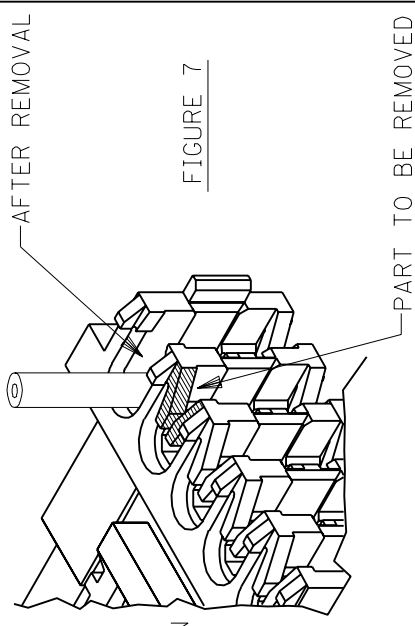

### STEP 2 - REMOVAL OF TERMINAL

INSERT THE REMOVAL TOOL (#HT60630A) INTO THE FRONT OF OF THE CONNECTOR (AROUND THE TERMINAL) TO DEPRESS LOCK TANGS. PUSH THE TERMINAL/WIRE OUT THE BACK OF THE CONNECTOR.

REV.

SHT.

FILE NAME  
T71690X3



= 0



= 0

REVISE ONLY ON CAD SYSTEM

REV.

B

THIS DRAWING CONTAINS INFORMATION THAT IS PROPRIETARY TO MOLEX INC. AND SHOULD NOT BE USED WITHOUT WRITTEN PERMISSION.

SHT.

3

DRWG. NO. SMES-71690-0000

DRWG. NO. SMES-71690-0000



**MOLEX INCORPORATED**  
LISLE, ILL. 60532 U.S.A.

## WIRE TERMINATION SPECIFICATION

STEP 3 -CONDUCTOR REMOVAL  
USING A SMALL PAIR OF PLIERS SPREAD THE I.D.T. SLOT  
AND REMOVE CONDUCTOR BY PUSHING IN DIRECTION SHOWN

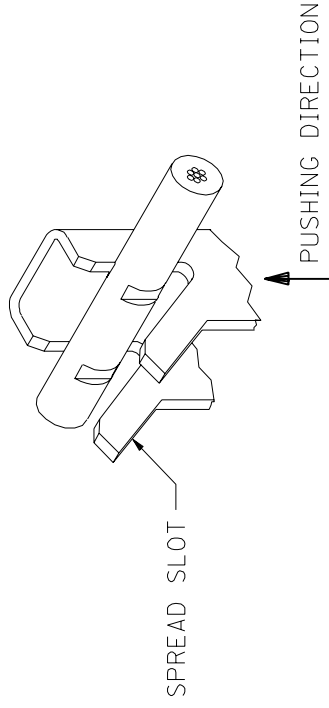

STEP 4 -REMOVING INSULATION  
INSULATION TO BE REMOVED WITHOUT DISTURBING I.D.T. AREA

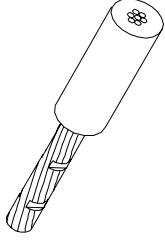

STEP 5 -CONDUCTOR INSPECTION  
FOUR DEFORMATION POINTS MUST BE CLEARLY VISIBLE WHEN  
USING 10X MAGNIFICATION

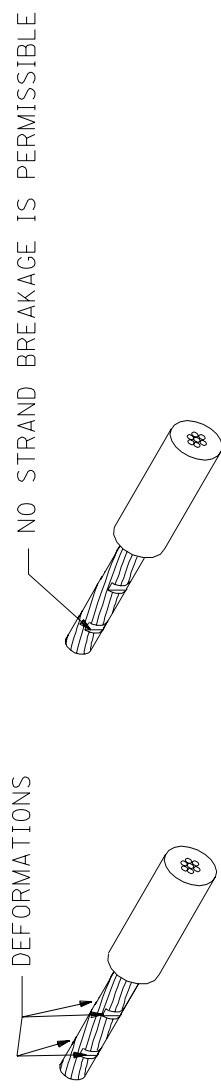

DRWG. NO. SMES-71690-0000

DRWG. NO. SMES-71690-0000

REV.	FILE NAME	REVISION	REV.
SHT.	T71690X4	= 0	B
		▲ = 0	
		◁ = 0	4

REVISE ONLY ON CAD SYSTEM

THIS DRAWING CONTAINS INFORMATION THAT IS PROPRIETARY TO  
MOLEX INC. AND SHOULD NOT BE USED WITHOUT WRITTEN PERMISSION.



**MOLEX INCORPORATED**  
LISLE, ILL. 60532 U.S.A.

## WIRE TERMINATION SPECIFICATION

LTR.	REVISIONS
A	RELEASED PER ECR U51189 09/15/95 SAS
B	UPDATED PER ECR U70308 ELO 09/20/96

### STEP 1 -REMOVAL OF TERMINAL

INSERT THE REMOVAL TOOL(\*HT60630A) INTO THE FRONT OF OF THE CONNECTOR (AROUND THE TERMINAL) TO DEPRESS LOCK TANGS.  
PUSH THE TERMINAL/WIRE OUT THE BACK OF THE CONNECTOR.

### STEP 2 -WIRE GAGE PER CHART

ID LETTER	WIRE GAGE
D	18 AWG
C	20 AWG
B	22 AWG
A	24 AWG

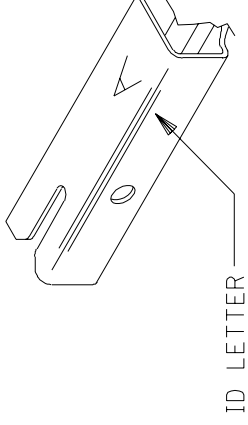

FIGURE 8

DRWG. NO. SMES-71690-0000

DRWG. NO. SMES-71690-0000

REV.

SHT.

FILE NAME  
T71690X5

□ = 0    ▲ = 0

REVISE ONLY ON CAD SYSTEM

REV. B

THIS DRAWING CONTAINS INFORMATION THAT IS PROPRIETARY TO MOLEX INC. AND SHOULD NOT BE USED WITHOUT WRITTEN PERMISSION.

SHT. 5