

注記 NOTES

1. 使用材料 MATERIAL

ハウジング : 液晶ポリマー (LCP) UL94V-0 (黒)
 60極品はLCPのグレードが異なります。
 HOUSING:LIQUID CRYSTAL POLYMER UL94V-0 (COLOR:BLACK)
 ターミナル : 銅合金
 TERMINAL : COPPER ALLOY
 金具 : 銅合金
 FITTING NAIL : COPPER ALLOY

△ (全極数 / 2) = 偶数の場合に適用。
 APPLY FOR (CIRCUIT/2)-EVEN.

4. 嵌合相手 : 503304 シリーズ
 MATE WITH : 503304 SERIES.

5. テール平坦度は、0.08 以下
 テール及び金具の平坦度は、0.1 以下
 TAIL COPLANARITY TO BE 0.08MAXIMUM.
 TAIL AND FITTING NAIL COPLANARITY TO BE 0.1MAXIMUM.

2. メッキ仕様 PLATING

ターミナル TERMINAL

金メッキ
 GOLD
 下地メッキ : ニッケルメッキ
 UNDER PLATING : NICKEL

※コンタクト部とテール部はニッケルメッキによって分断されている金メッキです。
 DIVIDE INTO PARTS THE GOLD PLATING OF THE CONTACT AND THE TAIL PART BY THE NICKEL PLATING.

金具 FITTING NAIL

錫メッキ
 Tin PLATING
 下地メッキ : ニッケルメッキ
 UNDER PLATING : NICKEL

11.6	13.47	503308-6020	60
9.6	11.47	503308-5010	50
8.4	10.27	503308-4410	44
8.0	9.87	503308-4210	42
7.6	9.47	503308-4010	40
5.6	7.47	503308-3010	30
4.8	6.67	503308-2610	26
4.4	6.27	503308-2410	24
3.6	5.47	503308-2010	20
3.2	5.07	503308-1810	18
2.8	4.67	503308-1610	16
2.0	3.87	503308-1210	12
B	A	EMBOSSSED PACKAGE	
		オーダー番号 ORDER No.	極数 CIRCUITS
		CONNECTOR SERIES No. : 503308-**09	

REVISED EC NO: J2011-0495 DRWN: M. AKAHASHI 03/20/10/05/14 CHKD: 20/10/10/05 APPR: MSASAO 20/10/10/05	DESCRIPTION	GENERAL TOLERANCES (UNLESS SPECIFIED)		DIMENSION STYLE MM ONLY		SCALE 15:1	DESIGN UNITS METRIC	THIRD ANGLE PROJECTION	
		10 UNDER	±0.2	DRAWN BY KSASAKI	DATE 2008/04/17	TITLE 0.4 B-TO-B CONN. HGT=0.7 W=2.6 PLUG ASS'Y			
		10 OVER 30 UNDER	±0.25	CHECKED BY THIRATA	DATE 2008/04/17	MOLEX INCORPORATED			
		30 OVER	±0.3	APPROVED BY MSASAO	DATE 2008/04/17				
		ANGULAR ±1 °		DRAFT WHERE APPLICABLE MUST REMAIN WITHIN DIMENSIONS		MATERIAL NO. SEE CHART		DOCUMENT NO. SD-503308-001	SHEET NO. 1 OF 2
SIZE A3		THIS DRAWING CONTAINS INFORMATION THAT IS PROPRIETARY TO MOLEX INCORPORATED AND SHOULD NOT BE USED WITHOUT WRITTEN PERMISSION							

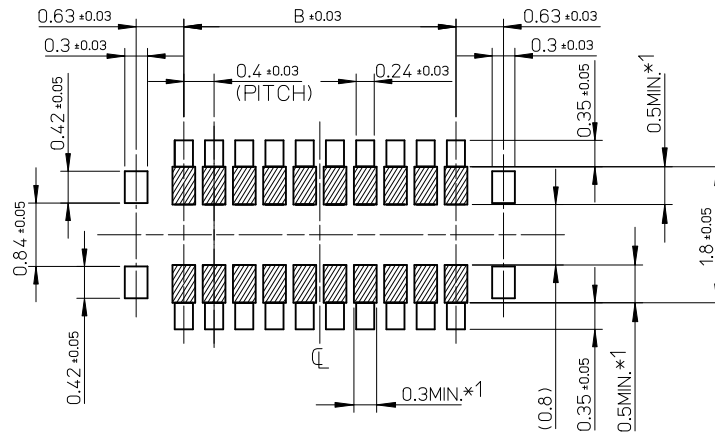

*1 パターン引き回し、および半田禁止エリア
 (当該箇所においては、これと接する回路以外の配線を禁止する。
 また、接する回路を配線する場合はレジストを施し、この部分に
 半田は無きこととする。)

*1 PROHIBITED AREA OF PATTERN WIRING AND SOLDER.
 (FOR EACH AREA, THE WIRING THAT TOUCHES ON THE SOLDER
 CAN BE ATTACHED, THEN COVERED WITH A FILM TO KEEP SOLDER OUT.)

RECOMMENDED P.W. BOARD
 PATTERN LAYOUT

REVISED EC NO: J2011-0495 DRWN: MTAKAHASHI 2010/05/14 CHKD: 2010/10/05 APPR: MSASAO 2010/10/05	GENERAL TOLERANCES (UNLESS SPECIFIED)		DIMENSION STYLE MM ONLY		SCALE 15:1	DESIGN UNITS METRIC	THIRD ANGLE PROJECTION	
	10 UNDER	± 0.2	DRAWN BY KSASAKI	DATE 2008/04/17	TITLE 0.4 B-TO-B CONN. HGT=0.7 W=2.6 PLUG ASS'Y			
	10 OVER 30 UNDER	± 0.25	CHECKED BY THIRATA	DATE 2008/04/17				
	30 OVER	± 0.3	APPROVED BY MSASAO	DATE 2008/04/17	MOLEX INCORPORATED			
	ANGULAR ± 1 °		MATERIAL NO.	SEE CHART				
DRAFT WHERE APPLICABLE MUST REMAIN WITHIN DIMENSIONS		THIS DRAWING CONTAINS INFORMATION THAT IS PROPRIETARY TO MOLEX INCORPORATED AND SHOULD NOT BE USED WITHOUT WRITTEN PERMISSION						

注記 NOTES

- 製品詳細寸法については製品単体図面を参照下さい。
RE DETAILED DIMENSION, SEE PRODUCT DRAWING.
- 梱包数量: 3000 個/リール
NUMBER OF CONNECTORS : 3000PCS/REEL
- リードテープ長さ LEAD TAPE LENGTH

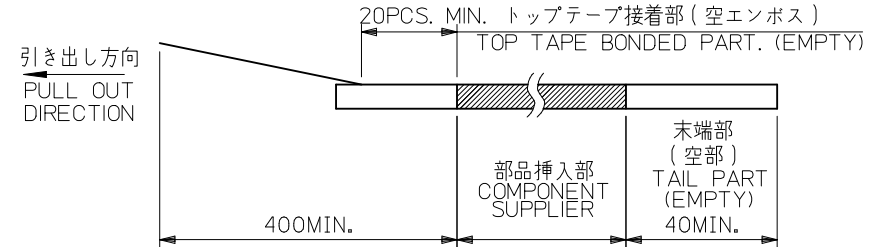

- トップテープの剥離強度: 0.1N~1.3N(10gf~130gf)
(剥離方向は下図参照)
尚、本規格値は出荷時に適用。(但し、輸送時に剥離が発生しないこと。)
PEELING OFF FORCE OF TOP TAPE : 0.1N~1.3N(10gf~130gf)
(PEELING DIRECTION AS SHOWN IN FOLLOWING FIG.)
THIS REQUIREMENT SHOULD BE APPLIED AT SHIPMENT.
PEEL OFF SHOULD NOT BE ALLOWED , DURING TRANSPORTION.

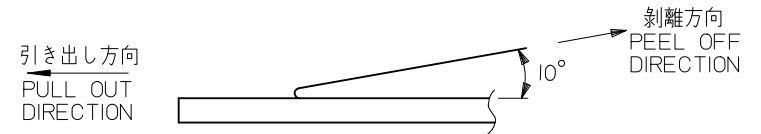

- 材料 MATERIAL
キャリアテープ (CARRIER TAPE) : ポリスチレン (POLYSTYRENE)
トップテープ (TOP TAPE) : PET , OTHER
リール (REEL) : ポリスチレン (PS) <リサイクル材を含む>
POLYSTYRENE (PS) <RECYCLE MATERIAL CONTAINED>
- ELV 及び RoHS適合品
ELV AND RoHS COMPLIANT

10 9 8 7 6 5 4 3 2 1

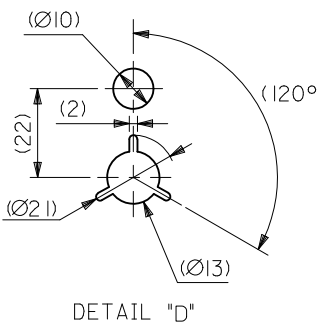
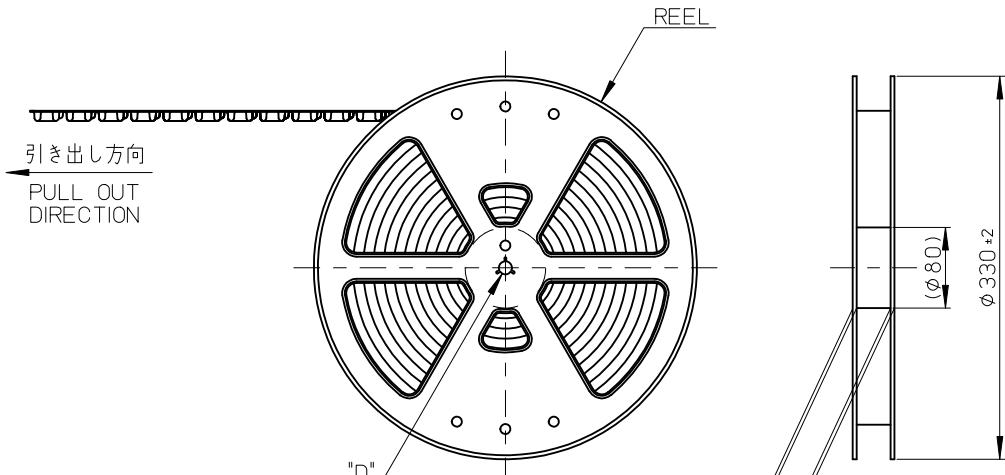

REVISED EC NO: J2011-0495 DRWN:KSASAKI CHKD: APPR:MSASAO	2010/08/16	2010/10/05	GENERAL TOLERANCES (UNLESS SPECIFIED)		DIMENSION STYLE MM ONLY		SCALE	DESIGN UNITS	MODEL NO.	503308-**10	
	10 UNDER	±0.2	10 OVER	30 UNDER	±0.25	DRAWN BY	DATE	TITLE	THIRD ANGLE PROJECTION		
	30 OVER	±0.3	ANGULAR	±1 °	DRAFT WHERE APPLICABLE MUST REMAIN WITHIN DIMENSIONS	CHECKED BY	DATE	0.4 B-TO-B CONN. HGT=0.7 PLUG ASSY EMBSTP PKG			
	APPROVED BY			DATE	MATERIAL NO.		DOCUMENT NO.		SHEET NO.		
	MSASAO			2008/12/12	SEE CHART		SD-503308-002		1 OF 3		

引き出し方向
PULL OUT DIRECTION

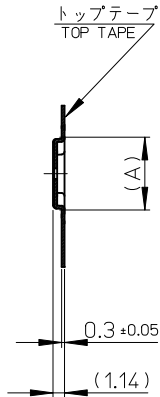

SECTION Y-Y

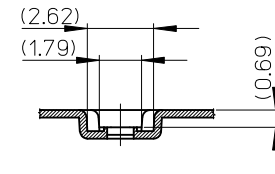
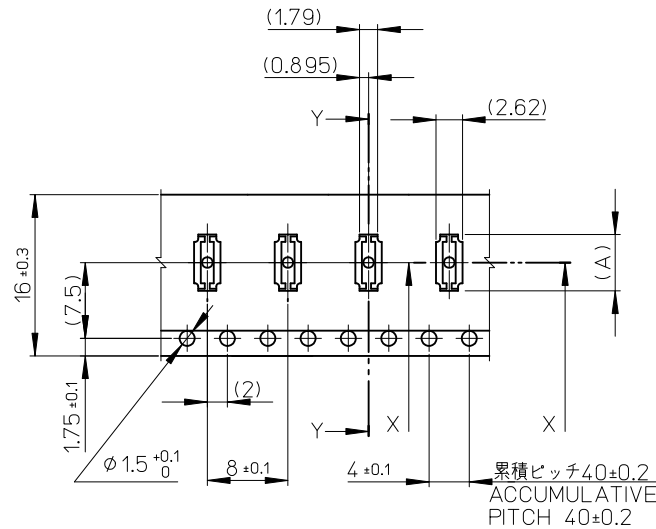

SECTION X-X

16mm 幅キャリアテープ
16mm WIDTH CARRIER TAPE

16	21.4	17.4	6.79	503308-2610	26
			6.39	503308-2410	24
			5.59	503308-2010	20
			5.19	503308-1810	18
			4.79	503308-1610	16
			3.99	503308-1210	12
キャリアテープ幅 CARRIER TAPE WIDTH			C	B	(A)
			MATERIAL No.		CKT.
			MODEL No.		503308-**-10

REVISED EC NO: J2011-0495 DRWN:KSASAKI CHKD: APPR:MSASAO 2010/08/16 2010/10/05 2010/10/05	DESCRIPTION REV	GENERAL TOLERANCES (UNLESS SPECIFIED)		DIMENSION STYLE MM ONLY		SCALE	DESIGN UNITS	THIRD ANGLE PROJECTION		
		10 UNDER	±0.2	DRAWN BY DATE		TITLE		MOLEX INCORPORATED 0.4 B-TO-B CONN. HGT=0.7 PLUG ASSY EMBSTP PKG		
		10 OVER 30 UNDER	±0.25	CHECKED BY DATE		DRAWN BY DATE				
		30 OVER	±0.3	APPROVED BY DATE		CHECKED BY DATE		DOCUMENT NO.		SHEET NO.
ANGULAR ±1°		DRAFT WHERE APPLICABLE MUST REMAIN WITHIN DIMENSIONS		MATERIAL NO.		SD-503308-002		2 OF 3		
				SIZE A3		THIS DRAWING CONTAINS INFORMATION THAT IS PROPRIETARY TO MOLEX INCORPORATED AND SHOULD NOT BE USED WITHOUT WRITTEN PERMISSION				

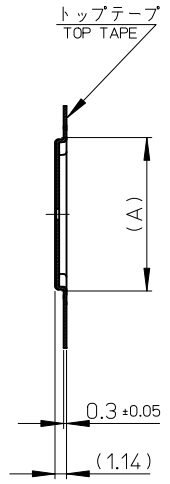

SECTION Y-Y

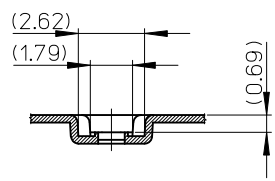
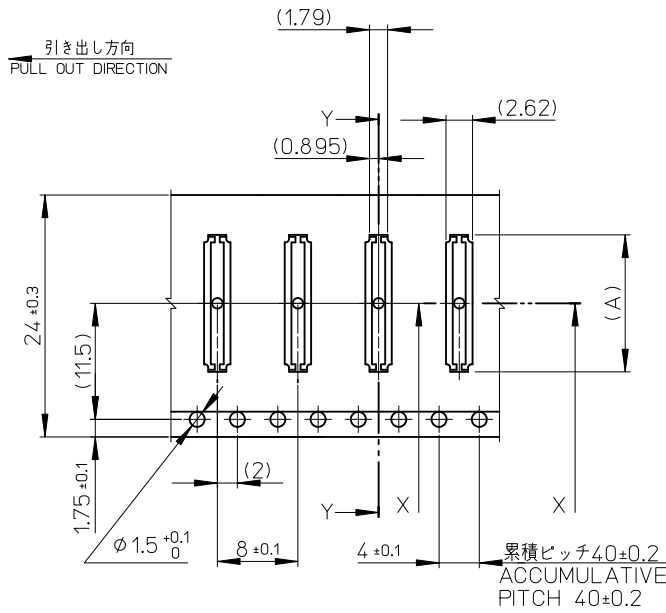

SECTION X-X

24mm 幅キャリアテープ
24mm WIDTH CARRIER TAPE

24	29.4	25.4	13.59	503308-6020	60
			11.59	503308-5010	50
			10.39	503308-4410	44
			9.99	503308-4210	42
			9.59	503308-4010	40
			7.59	503308-3010	30
キャリアテープ幅 CARRIER TAPE WIDTH			C	B	(A)
			MATERIAL No.		CKT.
			MODEL No.	503308-**-10	

REVISED EC NO: J2011-0495 DRW:KSASAKI CHKD: APPR:MSASAO 2010/08/16 2010/10/05 2010/10/05	DESCRIPTION REV	GENERAL TOLERANCES (UNLESS SPECIFIED)		DIMENSION STYLE MM ONLY		SCALE	DESIGN UNITS	THIRD ANGLE PROJECTION	
		10 UNDER	± 0.2	DRAWN BY DATE		TITLE	METRIC	MOLEX INCORPORATED 0.4 B-TO-B CONN. HGT=0.7 PLUG ASSY EMBSTP PKG	
		10 OVER 30 UNDER	± 0.25	KSASAKI 2008/12/12					
		30 OVER	± 0.3	THIRATA 2008/12/12					
ANGULAR ± 1 °		APPROVED BY DATE		MATERIAL NO.		DOCUMENT NO.		SHEET NO.	
DRAFT WHERE APPLICABLE MUST REMAIN WITHIN DIMENSIONS		MSASAO 2008/12/12		SEE CHART		SD-503308-002		3 OF 3	
THIS DRAWING CONTAINS INFORMATION THAT IS PROPRIETARY TO MOLEX INCORPORATED AND SHOULD NOT BE USED WITHOUT WRITTEN PERMISSION									