

参考基板レイアウト (マウント面)

P.C. BOARD PATTERN DIMENSION (REF.) (MOUNTING AREA)

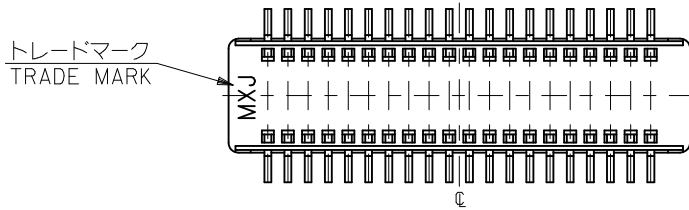
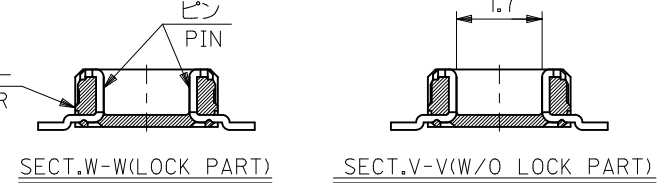

NON	20.55	19.5	21.45	55560-0801	80
10,21	15.55	14.5	16.45	-0601	60
2,4,8,10,16,18,22,24	13.05	12.0	13.95	-0501	50
2,3,5,6,8,9,12,13,15,16,18,19	10.55	9.5	11.45	-0401	40
2,3,4,5,7,8,9,10,11,13,14,15,16	9.05	8.0	9.95	-0341	34
ALL	8.05	7.0	8.95	-0301	30
	6.55	5.5	7.45	-0241	24
	6.05	5.0	6.95	-0221	22
	5.55	4.5	6.45	-0201	20
4.55	3.5	5.45	55560-0161	16	
LOCK POSITION	C	B	A	MATERIAL NO.	極数 CIRCUIT

REVISED EC NO: J2012-0135 DRWN: YON002 CHKD: TASAKAWA APPR: MSASAO	DESCRIPTION 2011/07/01 2011/07/01 2011/07/29	GENERAL TOLERANCES (UNLESS SPECIFIED)		DIMENSION STYLE MM ONLY		SCALE ---	DESIGN UNITS METRIC	THIRD ANGLE PROJECTION	
		10 UNDER	±0.20	DRAWN BY SAIHARA	DATE 2003/03/31	TITLE 0.5 B-TO-B CONN PLUG ASSY (HGT=1.5)			
		10 OVER 30 UNDER	±0.25	CHECKED BY MSASAO	DATE 2003/03/31	MOLEX INCORPORATED			
		30 OVER	±0.30	APPROVED BY MSASAO	DATE 2003/03/31	DOCUMENT NO. SD-55560-006			
ANGULAR ±3 °		DRAFT WHERE APPLICABLE MUST REMAIN WITHIN DIMENSIONS		MATERIAL NO. SEE CHART		SHEET NO. 1 OF 2		THIS DRAWING CONTAINS INFORMATION THAT IS PROPRIETARY TO MOLEX INCORPORATED AND SHOULD NOT BE USED WITHOUT WRITTEN PERMISSION	

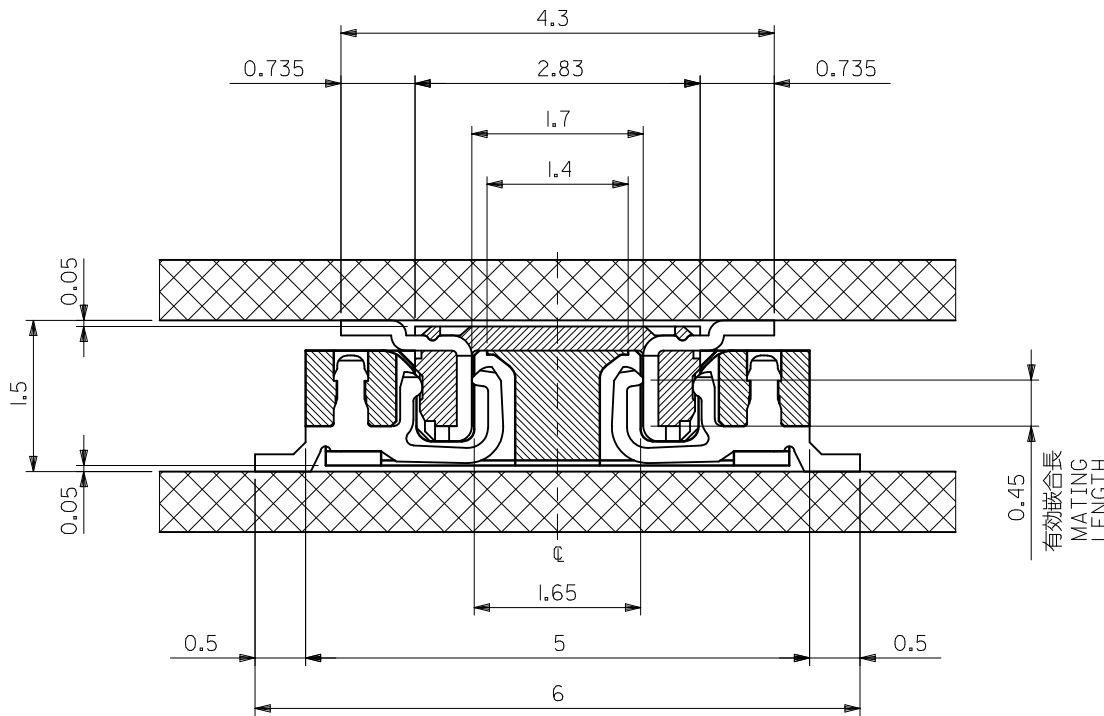

注記 NOTES:

1. 使用材料 MATERIAL
 ウェハー: 液晶ポリマー ガラス充填 ,UL94V-0(黒)
 WAFER : LIQUID CRYSTAL POLYMER
 (GLASS FILLED), UL94V-0 (COLOR: BLACK)
 ピン : 黄銅 (t=0.15)
 PIN : BRASS (t=0.15)
2. メッキ仕様 PLATING
 金メッキ 0.25 MICROMETER MINIMUM (コンタクト部)
 GOLD 0.25 MICROMETER MINIMUM (CONTACT AREA).
 金メッキ 0.4 MICROMETER MAXIMUM (テール部)
 GOLD 0.4 MICROMETER MAXIMUM (TAIL AREA).
 下地メッキ: ニッケルメッキ 1.5 MICROMETER MINIMUM
 UNDER PLATING : NICKEL 1.5 MICROMETER MINIMUM.
3. (全極数/2) = 偶数の場合に適用。
 APPLY FOR (CIRCUIT/2)=EVEN.
4. 嵌合相手: 54722 シリーズ, 54037 シリーズ
 MATE WITH : 54722 SERIES, 54037 SERIES.
5. テール平坦度は、0.1 MAXIMUM
 TAIL COPLANARITY TO BE 0.1 MAXIMUM.

嵌合断面図 (参考)
 MATED DRAWING (REF.)

REVISED EC NO: J2012-0135 DRWN: YON002 2011/07/01 CHKD: TASAKAWA 2011/07/01 APPR: MSASAO 2011/07/29	GENERAL TOLERANCES (UNLESS SPECIFIED)		DIMENSION STYLE MM ONLY	SCALE ---	DESIGN UNITS METRIC	THIRD ANGLE PROJECTION	
	10 UNDER	± 0.20	DRAWN BY SAIHARA	DATE 2000/10/05	TITLE 0.5 B-T-O-B CONN PLUG ASSY (HGT=1.5)		
	10 OVER 30 UNDER	± 0.25	CHECKED BY MSASAO	DATE 2003/03/31	MOLEX INCORPORATED		
	30 OVER	± 0.30	APPROVED BY MSASAO	DATE 2003/03/31	MATERIAL NO. SEE SHEET 1	DOCUMENT NO. SD-55560-006	SHEET NO. 2 OF 2
	ANGULAR ±3 ° DRAFT WHERE APPLICABLE MUST REMAIN WITHIN DIMENSIONS		SIZE A3	THIS DRAWING CONTAINS INFORMATION THAT IS PROPRIETARY TO MOLEX INCORPORATED AND SHOULD NOT BE USED WITHOUT WRITTEN PERMISSION			

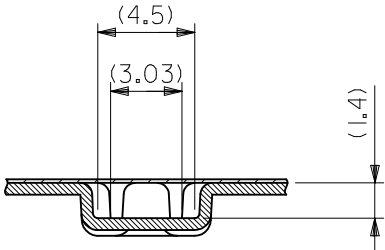
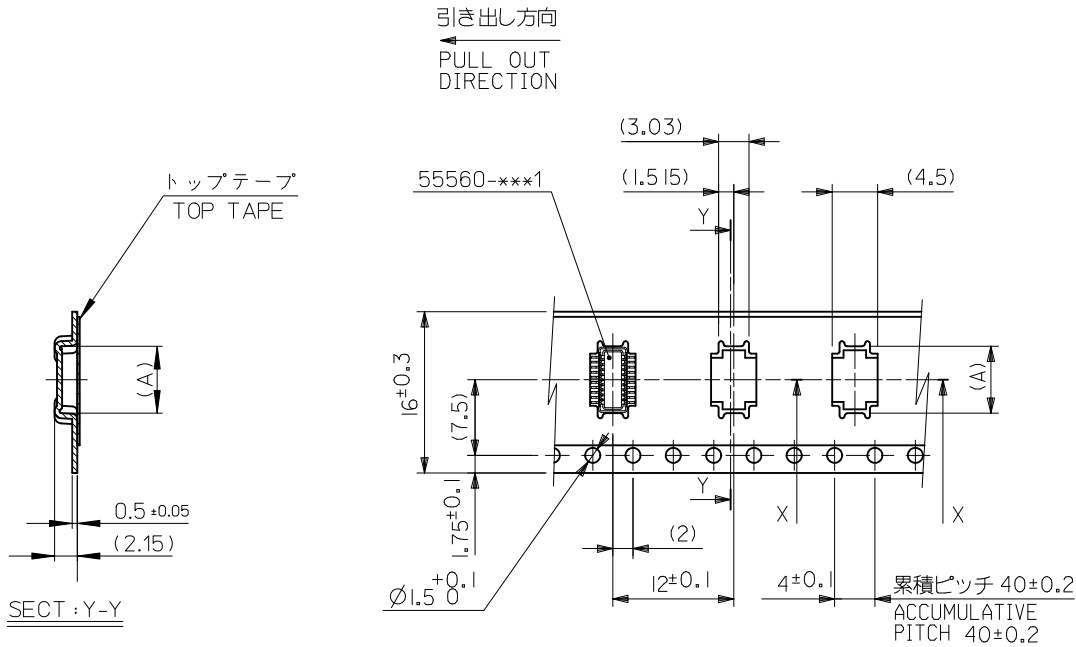

SECTION X-X
SCALE 5:1

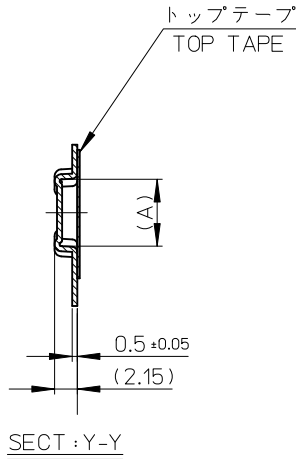

16mm幅キャリアテープ
16mm WIDTH CARRIER TAPE

16	17.5	6.65	55560-0207	55560-***7	20
キャリアテープ幅 CARRIER TAPE WIDTH	B	(A)	MATERIAL No.	MODEL No.	極数 CIRCUIT

REVISED EC NO: J2010-1529 DRWN: YON002 CHKD: SMARUYAMA APPR: MSASAO	DESCRIPTION 2010/01/28 2010/02/01 2010/02/01	GENERAL TOLERANCES (UNLESS SPECIFIED)		DIMENSION STYLE	SCALE	DESIGN UNITS	THIRD ANGLE PROJECTION	
				MM ONLY	---	METRIC		
		10 UNDER	±0.2	DRAWN BY	DATE	TITLE		
		10 OVER 30 UNDER	±0.25	S. AIHARA	'00/10/06	0.5 B-T0-B PLUG ASSY (HGT=1.5) EMBSTP PKG (SHEET 2 OF 5)		
30 OVER	±0.3	CHECKED BY	DATE	MOLEX INCORPORATED				
		M. SASAO	'03/03/31	MATERIAL NO.			SHEET NO.	
		APPROVED BY	DATE	DOCUMENT NO.				
		M. SASAO	'03/03/31	SEE CHART			2 OF 5	
		ANGULAR ±3 °		MATERIAL NO.				
		DRAFT WHERE APPLICABLE MUST REMAIN WITHIN DIMENSIONS		SD-55560-007				
				THIS DRAWING CONTAINS INFORMATION THAT IS PROPRIETARY TO MOLEX INCORPORATED AND SHOULD NOT BE USED WITHOUT WRITTEN PERMISSION				

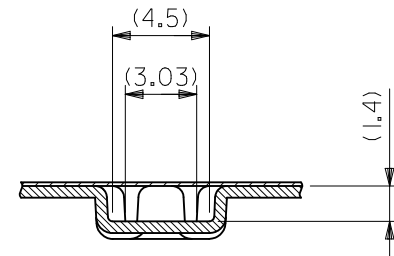
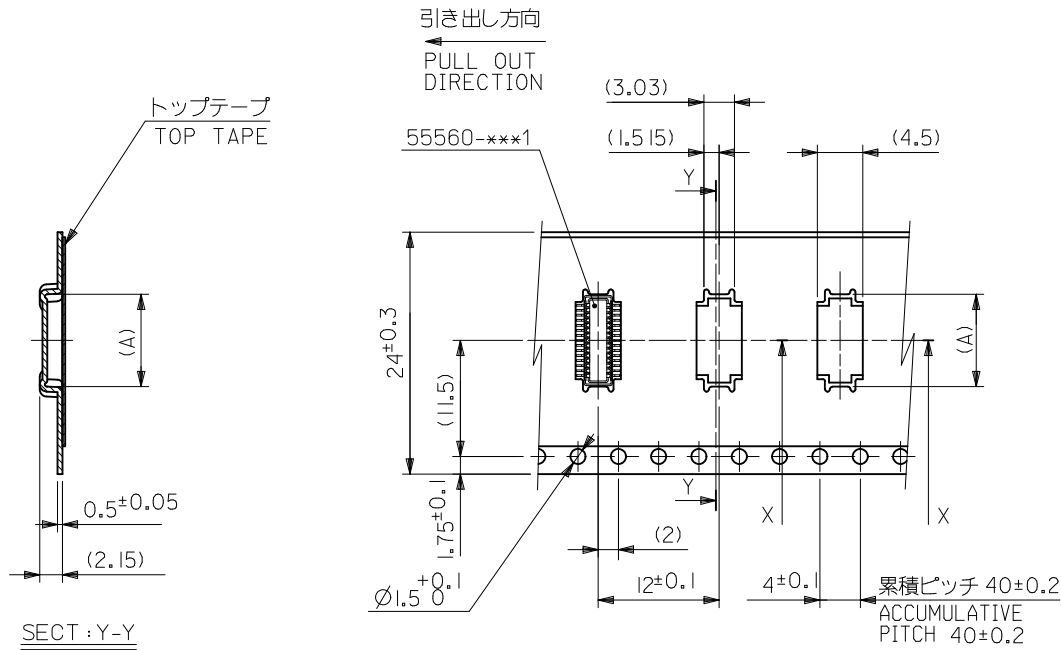

24mm幅キャリアテープ
24mm WIDTH CARRIER TAPE

24	25.5	14.15	55560-0507	55560-***7	50
		11.65	55560-0407		40
		10.15	55560-0347		34
		9.15	55560-0307		30
		7.65	55560-0247		24
		7.15	55560-0227		22
キャリアテープ幅 CARRIER TAPE WIDTH	B	(A)	MATERIAL No.	MODEL No.	極数 CIRCUIT

REVISED EC NO: J2010-1529 DRWN: YON002 CHKD: SMARUYAMA APPR: MSASAO 2010/01/28 2010/02/01 2010/02/02	GENERAL TOLERANCES (UNLESS SPECIFIED)		DIMENSION STYLE MM ONLY		SCALE ---	DESIGN UNITS METRIC	THIRD ANGLE PROJECTION
	10 UNDER	±0.2	DRAWN BY S. AIHARA	DATE '00/10/06	TITLE 0.5 B-T0-B PLUG ASSY (HGT=1.5) EMBSTP PKG (SHEET 3 OF 5)		
	10 OVER 30 UNDER	±0.25	CHECKED BY M. SASAO	DATE '03/03/31	MOLEX INCORPORATED		
	30 OVER	±0.3	APPROVED BY M. SASAO	DATE '03/03/31	DOCUMENT NO. SD-55560-007		
	ANGULAR ±3 °	DRAFT WHERE APPLICABLE MUST REMAIN WITHIN DIMENSIONS		MATERIAL NO. SEE TABLE		SHEET NO. 3 OF 5	
J	REV	THIS DRAWING CONTAINS INFORMATION THAT IS PROPRIETARY TO MOLEX INCORPORATED AND SHOULD NOT BE USED WITHOUT WRITTEN PERMISSION					

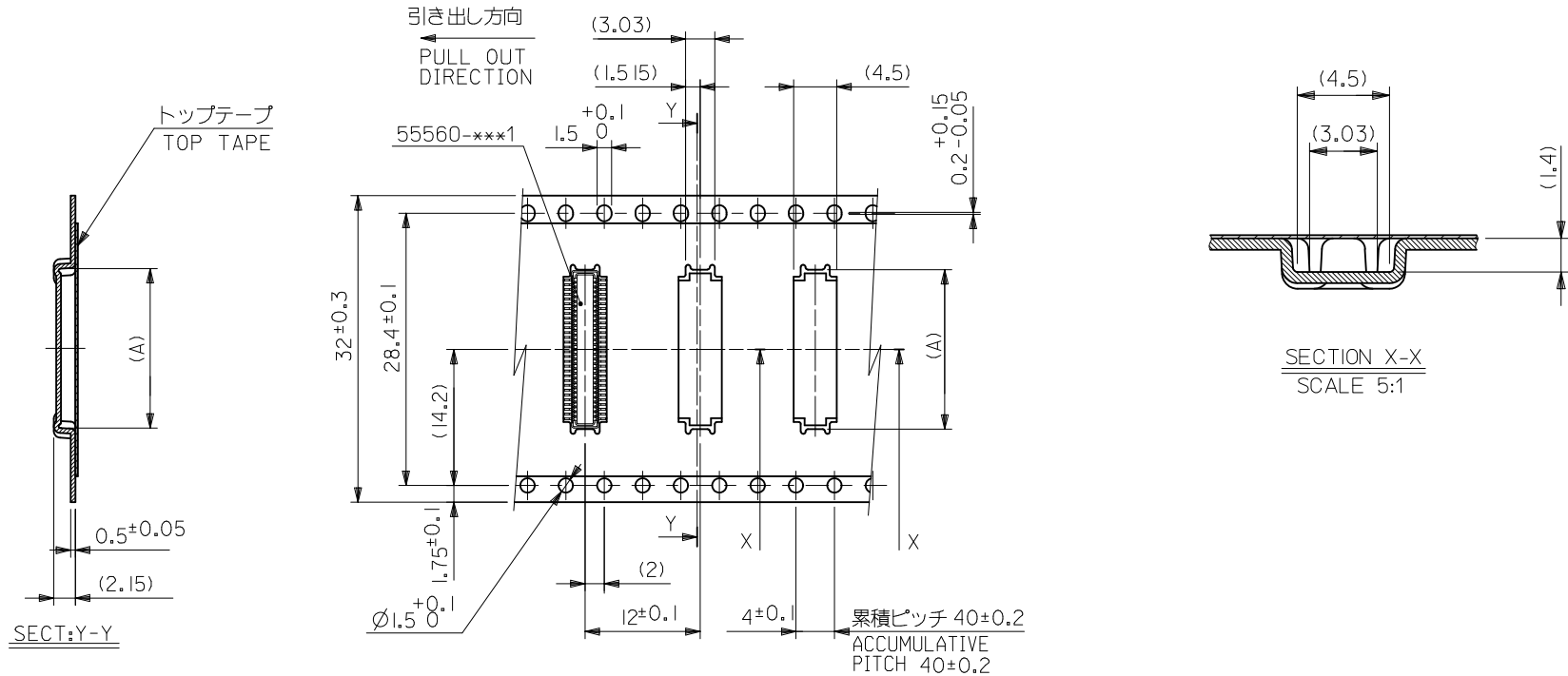

32mm幅キャリアテープ
32mm WIDTH CARRIER TAPE

32	33.5	16.65	55560-0607	55560-***7	60
キャリアテープ幅 CARRIER TAPE WIDTH	B	(A)	MATERIAL No.	MODEL No.	極数 CIRCUIT

REVISED EC NO: J2010-1529 DRWN: YON002 CH'KD: SMARUYAMA APPR: MSASAO 2010/01/28 2010/02/01 2010/02/02	GENERAL TOLERANCES (UNLESS SPECIFIED)		DIMENSION STYLE MM ONLY		SCALE ---	DESIGN UNITS METRIC	THIRD ANGLE PROJECTION
	10 UNDER	±0.2	DRAWN BY T. YASUI	DATE '02/03/06	TITLE 0.5 B-T0-B PLUG ASSY (HGT=1.5) EMBSTP PKG (SHEET 4 OF 5)		
	10 OVER 30 UNDER	±0.25	CHECKED BY M. SASAO	DATE '03/03/31	MOLEX INCORPORATED		
	30 OVER	±0.3	APPROVED BY M. SASAO	DATE '03/03/31	MATERIAL NO. SEE CHART	DOCUMENT NO. SD-55560-007	SHEET NO. 4 OF 5
	ANGULAR ±3 °	THIS DRAWING CONTAINS INFORMATION THAT IS PROPRIETARY TO MOLEX INCORPORATED AND SHOULD NOT BE USED WITHOUT WRITTEN PERMISSION					
	DRAFT WHERE APPLICABLE MUST REMAIN WITHIN DIMENSIONS						

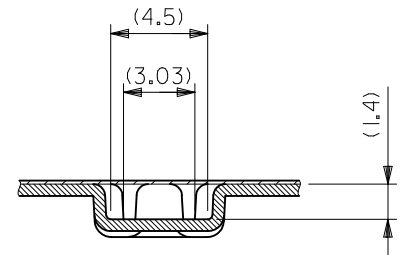
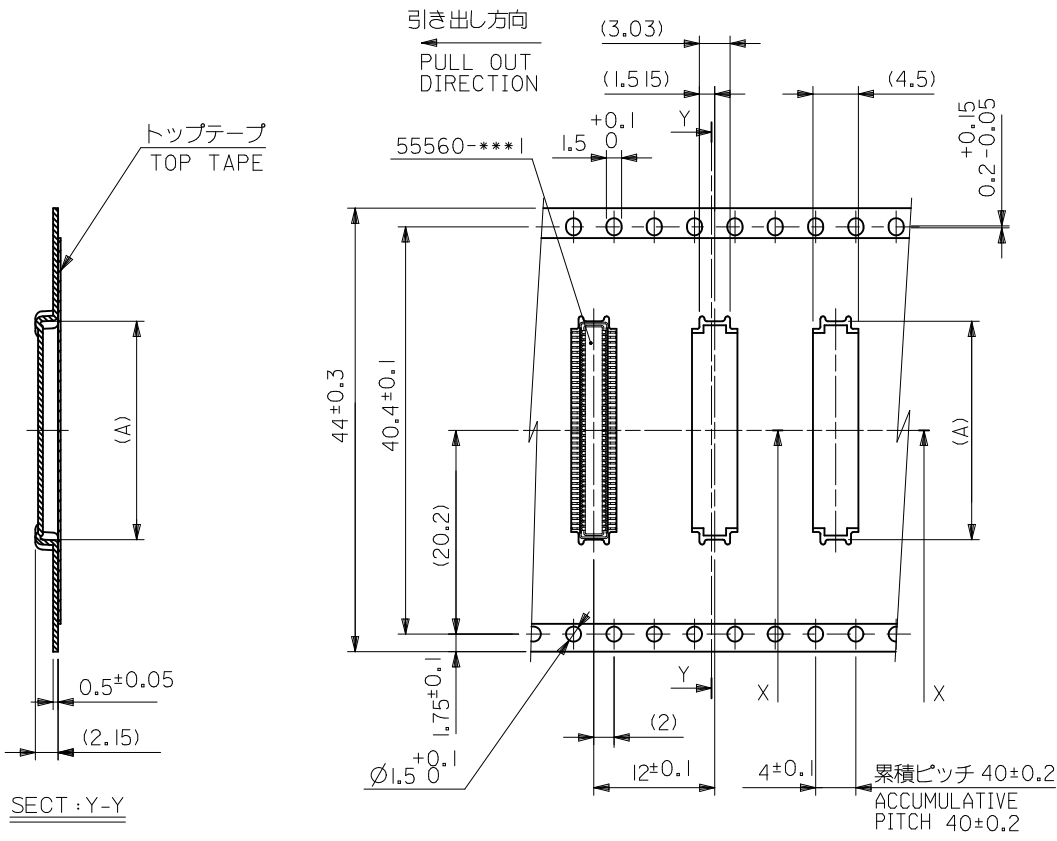

SECTION X-X
SCALE 5:1

SECT: Y-Y

44mm幅キャリアテープ
44mm WIDTH CARRIER TAPE

44	45.5	21.65	55560-0807	55560-***7	80
キャリアテープ幅 CARRIER TAPE WIDTH	B	(A)	MATERIAL No.	MODEL No.	極数 CIRCUIT

REVISED EC NO: J2010-1529 DRWN: YON002 CH'KD: SMARUYAMA APPR: MSASAO 2010/01/28 2010/02/01 2010/02/01	GENERAL TOLERANCES (UNLESS SPECIFIED)		DIMENSION STYLE MM ONLY		SCALE ---	DESIGN UNITS METRIC	THIRD ANGLE PROJECTION
	10 UNDER	±0.2	DRAWN BY S. AIHARA	DATE '00/10/06	TITLE 0.5 B-T0-B PLUG ASSY (HGT=1.5) EMBSTP PKG (SHEET 5 OF 5)		
	10 OVER 30 UNDER	±0.25	CHECKED BY M. SASAO	DATE '03/03/31	MOLEX INCORPORATED		
	30 OVER	±0.3	APPROVED BY M. SASAO	DATE '03/03/31	MATERIAL NO. SEE CHART	DOCUMENT NO. SD-55560-007	SHEET NO. 5 OF 5
J	REVISION	ANGULAR ±3 °	DRAFT WHERE APPLICABLE MUST REMAIN WITHIN DIMENSIONS		THIS DRAWING CONTAINS INFORMATION THAT IS PROPRIETARY TO MOLEX INCORPORATED AND SHOULD NOT BE USED WITHOUT WRITTEN PERMISSION		