

φ 5.00
MAX PICK AND PLACE AREA

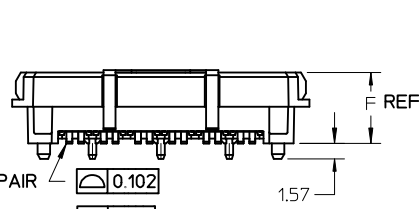

- FOR 6 AND 12 PAIR $\sqrt{0.102}$
- FOR 24 PAIR $\sqrt{0.114}$
- FOR 36 PAIR $\sqrt{0.127}$

N SURFACES
N = # OF CIRCUITS
(SEE NOTE 15)

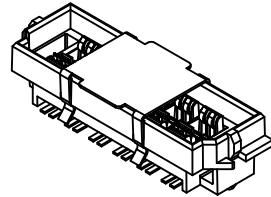
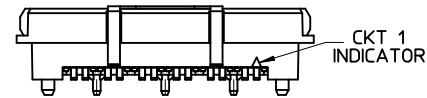
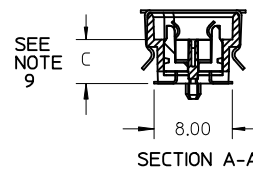
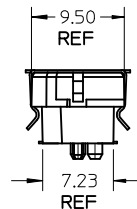

NOTES:

- 1) MATERIALS:
HOUSING - LIQUID CRYSTAL POLYMER, UL94 V-0, NATURAL
CHICKLET - LIQUID CRYSTAL POLYMER, UL94 V-0, BLACK
CONTACT - TIN BRASS
- 2) CONTACT PLATING FINISH:
0.76 MICRON MIN. SELECT GOLD AND
3.81 MICRON MIN. SELECT PURE TIN OVER
1.27 MICRON MIN. NICKEL OVERALL
- 3) HOUSING PLATING FINISH:
0.10 MICRON MAX. IMMERSION GOLD OVER
3.81 MICRON MIN. NICKEL OVER
3.81 MICRON MIN. COPPER OVERALL
- 4) 4.5mm 12 PAIR PLUG ASSEMBLY SHOWN.
- 5) PART CONFORMS TO MOLEX COSMETIC SPECIFICATION PS-75005-002.
- 6) PART PERFORMS TO MOLEX PRODUCT SPECIFICATION PS-75005-001.
- 7) PACKAGE PER PK-75003-002.
- 8) FOR AUTO-PLACEMENT APPLICATIONS: PCB ORIENTATION HOLE TO BE $\phi 1.65 \pm 0.05$
FOR HAND PLACEMENT APPLICATIONS: PCB ORIENTATION HOLE TO BE $\phi 1.45 \pm 0.05$
- 9) THIS DIMENSION CONTROLS THE STACK HEIGHT OF THE MATED CONNECTORS.
- 10) PLEASE REFER TO MOLEX APPLICATION SPECIFICATION AS-75005-001 FOR SUITABLE PROCESSING TEMPERATURES, PERMISSABLE OFFSETS, AND MATING SEQUENCES.
- 11) THESE PLATED THRU HOLES SHOULD BE CONNECTED TO SIGNAL GROUND.
- 12) THIS PART MATES WITH THE 75005 RECEPTACLE.
- 13) THIS PART IS RECOMMENDED TO BE PLACED ON THE MEZZANINE CARD.
- 14) HOUSING IS CONDUCTIVE, UNINSULATED TRACES MUST BE KEPT OUT OF KEEP-OUT ZONE.
- 15) EACH SIDE IS MEASURED TO A COMMON DATUM WITH-IN A COPLANARITY OF 0.102mm FOR 6 AND 12 PAIR, 0.114mm FOR 24 PAIR AND 0.127mm FOR 36 PAIR, THE SIDES MAY VARY TO EACH OTHER BY 0.05mm MAX.

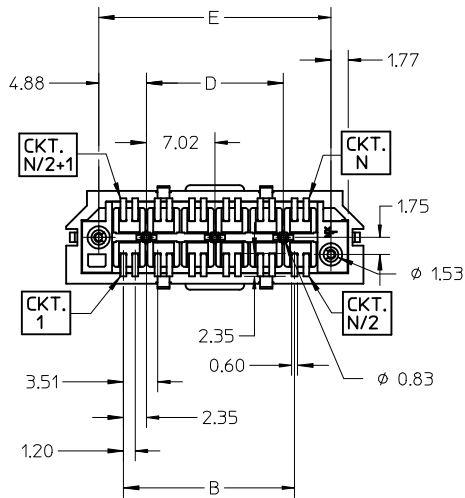

ADD PKG DETAILS EC NO: UCP2010-1785 DRW:MSI/BARRA 2010/01/22 CHKD:SDANNELLEY 2001/10/25 APPR:SMILLER 2010/01/28	QUALITY SYMBOLS $\nabla F=0$ $\nabla E=0$ $\nabla F=0$	GENERAL TOLERANCES (UNLESS SPECIFIED)	DIMENSION STYLE	SCALE	DESIGN UNITS	THIRD ANGLE PROJECTION	
		mm INCH	MM ONLY	2:1	METRIC		
		4 PLACES ± --- ± ---	DRAWN BY DATE	TITLE	SALES DRAWING FOR HIGH SPEED MEZZANINE PLUG		
		3 PLACES ± --- ± ---	KSTILES 2001/10/24				
2 PLACES ± 0.13 ± ---	CHECKED BY DATE	MOLEX INCORPORATED DOCUMENT NO. SD-75003-001 SHEET NO. 1 OF 8					
1 PLACE ± 0.25 ± ---	KREGNIER 2001/10/25						
ANGULAR ± 1/2°	APPROVED BY DATE	THIS DRAWING CONTAINS INFORMATION THAT IS PROPRIETARY TO MOLEX INCORPORATED AND SHOULD NOT BE USED WITHOUT WRITTEN PERMISSION					
DRAFT WHERE APPLICABLE MUST REMAIN WITHIN DIMENSIONS	SMILLER 2010/01/28						
	MATERIAL NO.	SEE TABLE					
	SIZE B						

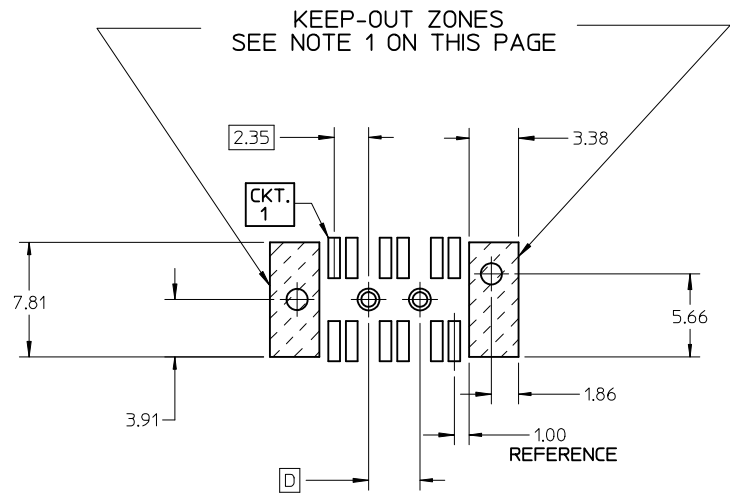

COMPONENT SIDE SHOWN
 RECOMMENDED PCB THICKNESS: 1.57mm
 FOR 12 CIRCUIT OPTION.
 FOR DIMENSIONS NOT SHOWN REFER TO
 THE 24-72 CIRCUIT PCB LAYOUT.

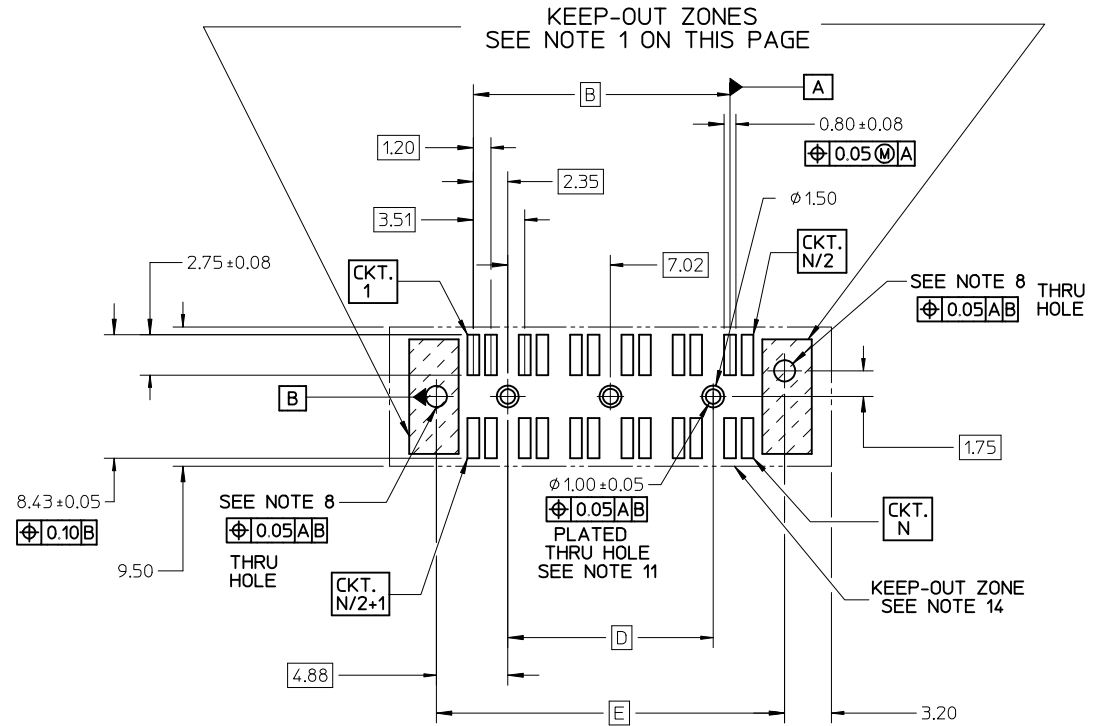

COMPONENT SIDE SHOWN
 RECOMMENDED PCB THICKNESS: 1.57mm
 FOR CIRCUIT SIZES FROM 24-72 CIRCUITS.

UNLESS OTHERWISE SPECIFIED, DIMENSIONS ARE COMMON TO BOTH VIEWS

NOTE:
 1. NO FEATURES (INCLUDING SOLDER PASTE) WHICH RISE ABOVE THE PCB SURFACE ALLOWED IN THIS AREA.

SEE SHEET 1 EC NO: UCP2010-1785 DRAWN BY: DRWINHS IBARRA 2010/01/22 CHECKED BY: CHKD:SDANNELLEY 2001/10/25 APPROVED BY: APPR:SMILLER 2010/01/28	DESCRIPTION REV	QUALITY SYMBOLS	GENERAL TOLERANCES (UNLESS SPECIFIED)	DIMENSION STYLE	SCALE	DESIGN UNITS	THIRD ANGLE PROJECTION	
		$\nabla F/0$ $\nabla E/0$ $\nabla F/0$	mm INCH 4 PLACES ± --- ± --- 3 PLACES ± --- ± --- 2 PLACES ± 0.13 ± --- 1 PLACE ± 0.25 ± --- ANGULAR ± 1/2°	MM ONLY	3:1	METRIC	DRAWN BY DATE KSTILES 2001/10/24 CHECKED BY DATE KREGNIER 2001/10/25 APPROVED BY DATE SMILLER 2010/01/28	TITLE
		DRAFT WHERE APPLICABLE MUST REMAIN WITHIN DIMENSIONS	SEE TABLE	MATERIAL NO.	DOCUMENT NO.	SALES DRAWING FOR HIGH SPEED MEZZANINE PLUG MOLEX INCORPORATED SD-75003-001		SHEET NO.
		SIZE B	THIS DRAWING CONTAINS INFORMATION THAT IS PROPRIETARY TO MOLEX INCORPORATED AND SHOULD NOT BE USED WITHOUT WRITTEN PERMISSION		2 OF 8			

10 9 8 7 6 5 4 3 2 1

TUBE PACKAGING

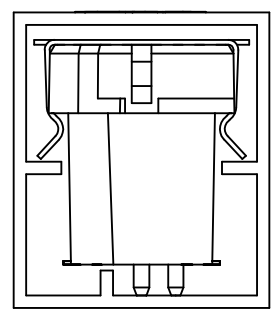

ORIENTATION OF PART IN TUBE

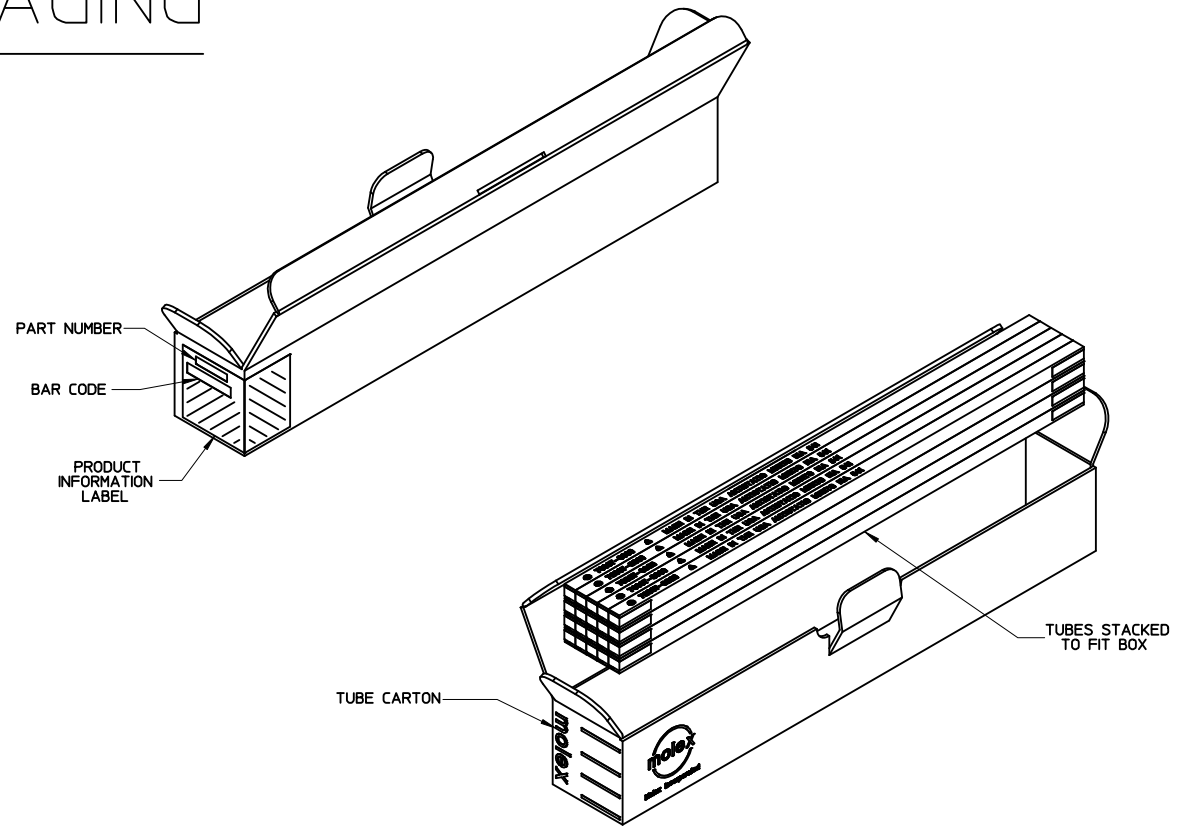

SEE SHEET 1 EC NO: UCP2010-4785 DRWNS:IBARRA 2010/01/22 CHKD:SDANNELLEY 2001/10/25 APPR:SMILLER 2010/01/28	QUALITY SYMBOLS $\nabla = 0$ $\nabla = 0$ $\nabla = 0$	GENERAL TOLERANCES (UNLESS SPECIFIED) <table border="1"> <thead> <tr> <th></th> <th>mm</th> <th>INCH</th> </tr> </thead> <tbody> <tr> <td>4 PLACES</td> <td>± ---</td> <td>± ---</td> </tr> <tr> <td>3 PLACES</td> <td>± ---</td> <td>± ---</td> </tr> <tr> <td>2 PLACES</td> <td>± 0.13</td> <td>± ---</td> </tr> <tr> <td>1 PLACE</td> <td>± 0.25</td> <td>± ---</td> </tr> <tr> <td colspan="3">ANGULAR ±1/2°</td> </tr> </tbody> </table>		mm	INCH	4 PLACES	± ---	± ---	3 PLACES	± ---	± ---	2 PLACES	± 0.13	± ---	1 PLACE	± 0.25	± ---	ANGULAR ±1/2°			DIMENSION STYLE MM ONLY DRAWN BY: KSTILES DATE: 2001/10/24 CHECKED BY: KREGNIER DATE: 2001/10/25 APPROVED BY: SMILLER DATE: 2010/01/28	SCALE: 3:1 DESIGN UNITS: METRIC THIRD ANGLE PROJECTION	TITLE: SALES DRAWING FOR HIGH SPEED MEZZANINE PLUG MOLEX INCORPORATED DOCUMENT NO. SD-75003-001 SHEET NO. 3 OF 8
		mm	INCH																				
	4 PLACES	± ---	± ---																				
	3 PLACES	± ---	± ---																				
2 PLACES	± 0.13	± ---																					
1 PLACE	± 0.25	± ---																					
ANGULAR ±1/2°																							
DRAFT WHERE APPLICABLE MUST REMAIN WITHIN DIMENSIONS	MATERIAL NO. SEE TABLE	THIS DRAWING CONTAINS INFORMATION THAT IS PROPRIETARY TO MOLEX INCORPORATED AND SHOULD NOT BE USED WITHOUT WRITTEN PERMISSION																					
SIZE: B																							

9 8 7 6 5 4 3 2 1

TAPE AND REEL PACKAGING

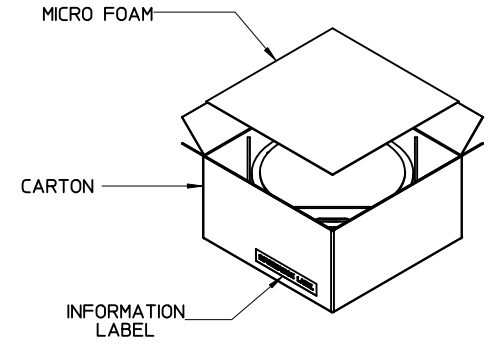
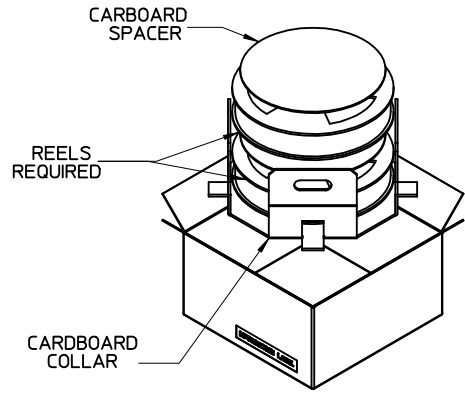
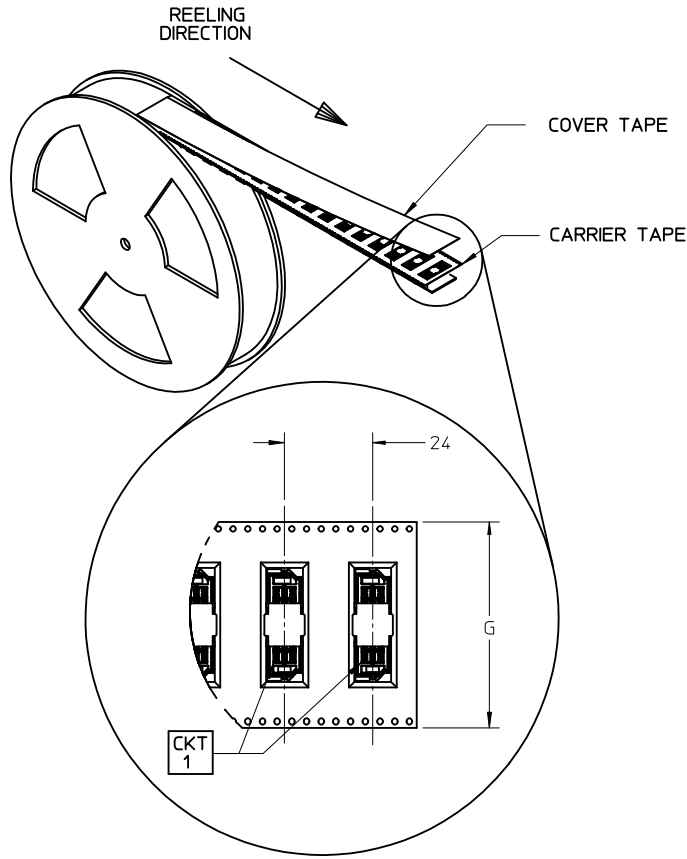

SEE SHEET 1 EC NO: UCP2010-1785 DRWNS:IBARRA 2010/01/22 CHKD:SDANNELLEY 2001/10/25 APPR:SMILLER 2010/01/28	QUALITY SYMBOLS	GENERAL TOLERANCES (UNLESS SPECIFIED)	DIMENSION STYLE MM ONLY		SCALE 2:1	DESIGN UNITS METRIC	THIRD ANGLE PROJECTION	
	▽=0	mm INCH	DRAWN BY	DATE	TITLE SALES DRAWING FOR HIGH SPEED MEZZANINE PLUG			
	▽=0	4 PLACES ± --- ± ---	KSTILES	2001/10/24				
	▽=0	3 PLACES ± --- ± ---	CHECKED BY	DATE	MOLEX INCORPORATED DOCUMENT NO. SD-75003-001 SHEET NO. 4 OF 8			
▽=0	2 PLACES ± 0.13 ± ---	KREGNIER	2001/10/25					
	1 PLACE ± 0.25 ± ---	APPROVED BY	DATE	THIS DRAWING CONTAINS INFORMATION THAT IS PROPRIETARY TO MOLEX INCORPORATED AND SHOULD NOT BE USED WITHOUT WRITTEN PERMISSION				
	ANGULAR ± 1/2°	SMILLER	2010/01/28					
		DRAFT WHERE APPLICABLE MUST REMAIN WITHIN DIMENSIONS		SEE TABLE				
				SIZE B				

PACKAGED IN TUBES

NUMBER OF CIRCUITS	NUMBER OF DIFFERENTIAL PAIRS	MATERIAL NUMBER	A	B	C	D	E	F	PARTS PER TUBE
12	6	NOT TOOLED	19.93	7.02	4.50	3.52	13.27	7.25	NOT TOOLED
12	6	750030305	19.93	7.02	5.50	3.52	13.27	8.25	28
12	6	NOT TOOLED	19.93	7.02	6.50	3.52	13.27	9.25	NOT TOOLED
12	6	750030308	19.93	7.02	8.50	3.52	13.27	11.25	28
12	6	750030310	19.93	7.02	10.50	3.52	13.27	13.25	28
12	6	NOT TOOLED	19.93	7.02	12.50	3.52	13.27	15.25	NOT TOOLED
24	12	NOT TOOLED	30.46	17.55	4.50	14.05	23.80	7.25	NOT TOOLED
24	12	750030005	30.46	17.55	5.50	14.05	23.80	8.25	18
24	12	NOT TOOLED	30.46	17.55	6.50	14.05	23.80	9.25	NOT TOOLED
24	12	750030008	30.46	17.55	8.50	14.05	23.80	11.25	18
24	12	750030010	30.46	17.55	10.50	14.05	23.80	13.25	18
24	12	NOT TOOLED	30.46	17.55	12.50	14.05	23.80	15.25	NOT TOOLED

SEE SHEET 1 EC NO: UCP2010-1785 DRWN:MS IBARRA 2010/01/22 CHKD:SDANNELLEY 2001/10/25 APPR:SMILLER 2010/01/28	QUALITY SYMBOLS $\nabla Z=0$ $\nabla Z=0$ $\nabla Z=0$	GENERAL TOLERANCES (UNLESS SPECIFIED) <table border="1" style="width: 100%; border-collapse: collapse;"> <tr> <th></th> <th>mm</th> <th>INCH</th> </tr> <tr> <td>4 PLACES</td> <td>± ---</td> <td>± ---</td> </tr> <tr> <td>3 PLACES</td> <td>± ---</td> <td>± ---</td> </tr> <tr> <td>2 PLACES</td> <td>± 0.13</td> <td>± ---</td> </tr> <tr> <td>1 PLACE</td> <td>± 0.25</td> <td>± ---</td> </tr> <tr> <td colspan="3" style="text-align: center;">ANGULAR ±1/2°</td> </tr> </table>		mm	INCH	4 PLACES	± ---	± ---	3 PLACES	± ---	± ---	2 PLACES	± 0.13	± ---	1 PLACE	± 0.25	± ---	ANGULAR ±1/2°			DIMENSION STYLE MM ONLY	SCALE 2:1	DESIGN UNITS METRIC	THIRD ANGLE PROJECTION
		mm	INCH																					
	4 PLACES	± ---	± ---																					
	3 PLACES	± ---	± ---																					
2 PLACES	± 0.13	± ---																						
1 PLACE	± 0.25	± ---																						
ANGULAR ±1/2°																								
DESCRIPTION DRAFT WHERE APPLICABLE MUST REMAIN WITHIN DIMENSIONS		DRAWN BY DATE KSTILES 2001/10/24 CHECKED BY DATE KREGNIER 2001/10/25 APPROVED BY DATE SMILLER 2010/01/28	TITLE SALES DRAWING FOR HIGH SPEED MEZZANINE PLUG																					
		MATERIAL NO. SEE TABLE	DOCUMENT NO. SD-75003-001		SHEET NO. 5 OF 8																			
THIS DRAWING CONTAINS INFORMATION THAT IS PROPRIETARY TO MOLEX INCORPORATED AND SHOULD NOT BE USED WITHOUT WRITTEN PERMISSION																								

PACKAGED IN TUBES

NUMBER OF CIRCUITS	NUMBER OF DIFFERENTIAL PAIRS	MATERIAL NUMBER	A	B	C	D	E	F	PARTS PER TUBE
48	24	NOT TOOLED	51.52	38.61	4.50	35.11	44.86	7.25	NOT TOOLED
48	24	750030105	51.52	38.61	5.50	35.11	44.86	8.25	10
48	24	NOT TOOLED	51.52	38.61	6.50	35.11	44.86	9.25	NOT TOOLED
48	24	NOT TOOLED	51.52	38.61	8.50	35.11	44.86	11.25	NOT TOOLED
48	24	750030110	51.52	38.61	10.50	35.11	44.86	13.25	10
48	24	NOT TOOLED	51.52	38.61	12.50	35.11	44.86	15.25	NOT TOOLED
72	36	NOT TOOLED	72.58	59.67	4.50	56.17	65.92	7.25	NOT TOOLED
72	36	750030205	72.58	59.67	5.50	56.17	65.92	8.25	7
72	36	NOT TOOLED	72.58	59.67	6.50	56.17	65.92	9.25	NOT TOOLED
72	36	NOT TOOLED	72.58	59.67	8.50	56.17	65.92	11.25	NOT TOOLED
72	36	750030210	72.58	59.67	10.50	56.17	65.92	13.25	7
72	36	NOT TOOLED	72.58	59.67	12.50	56.17	65.92	15.25	NOT TOOLED

SEE SHEET 1 EC NO: UCP2010-1785 DRWN:MS/BARRA 2010/01/22 CHKD:SDANNELLEY 2001/10/25 APPR:SMILLER 2010/01/28 H	QUALITY SYMBOLS F=0 F=0 F=0	GENERAL TOLERANCES (UNLESS SPECIFIED) mm INCH 4 PLACES ± --- ± --- 3 PLACES ± --- ± --- 2 PLACES ± 0.13 ± --- 1 PLACE ± 0.25 ± --- ANGULAR ± 1/2°	DIMENSION STYLE MM ONLY DRAWN BY DATE KSTILES 2001/10/24 CHECKED BY DATE KREGNIER 2001/10/25 APPROVED BY DATE SMILLER 2010/01/28	SCALE 3:1	DESIGN UNITS METRIC	THIRD ANGLE PROJECTION	SALES DRAWING FOR HIGH SPEED MEZZANINE PLUG MOLEX INCORPORATED	
	DRAFT WHERE APPLICABLE MUST REMAIN WITHIN DIMENSIONS		MATERIAL NO. SEE TABLE	DOCUMENT NO. SD-75003-001	SHEET NO. 6 OF 8		THIS DRAWING CONTAINS INFORMATION THAT IS PROPRIETARY TO MOLEX INCORPORATED AND SHOULD NOT BE USED WITHOUT WRITTEN PERMISSION	

PACKAGED IN TAPE AND REEL

NUMBER OF CIRCUITS	NUMBER OF DIFFERENTIAL PAIRS	MATERIAL NUMBER	A	B	C	D	E	F	CARRIER TAPE WIDTH G	PARTS PER REEL
12	6	NOT TOOLED	19.93	7.02	4.50	3.52	13.27	7.25	NOT TOOLED	
12	6	750032305	19.93	7.02	5.50	3.52	13.27	8.25	NOT TOOLED	
12	6	NOT TOOLED	19.93	7.02	6.50	3.52	13.27	9.25	NOT TOOLED	
12	6	750032308	19.93	7.02	8.50	3.52	13.27	11.25	NOT TOOLED	
12	6	750032310	19.93	7.02	10.50	3.52	13.27	13.25	NOT TOOLED	
12	6	NOT TOOLED	19.93	7.02	12.50	3.52	13.27	15.25	NOT TOOLED	
24	12	NOT TOOLED	30.46	17.55	4.50	14.05	23.80	7.25	NOT TOOLED	
24	12	750032005	30.46	17.55	5.50	14.05	23.80	8.25	NOT TOOLED	
24	12	NOT TOOLED	30.46	17.55	6.50	14.05	23.80	9.25	NOT TOOLED	
24	12	750032008	30.46	17.55	8.50	14.05	23.80	11.25	56	186
24	12	750032010	30.46	17.55	10.50	14.05	23.80	13.25	NOT TOOLED	
24	12	NOT TOOLED	30.46	17.55	12.50	14.05	23.80	15.25	NOT TOOLED	

SEE SHEET 1 EC NO: UCP2010-4785 DRW:MS IBARRA 2010/01/22 CHKD:SDANNELLEY 2001/10/25 APPR:SMILLER 2010/01/28	DESCRIPTION H	QUALITY SYMBOLS	GENERAL TOLERANCES (UNLESS SPECIFIED)	DIMENSION STYLE	SCALE	DESIGN UNITS	THIRD ANGLE PROJECTION	
		$\nabla F=0$ $\nabla E=0$ $\nabla D=0$	mm INCH 4 PLACES ± --- ± --- 3 PLACES ± --- ± --- 2 PLACES ± 0.13 ± --- 1 PLACE ± 0.25 ± ---	MM ONLY	3:1	METRIC	DRAWN BY DATE KSTILES 2001/10/24 CHECKED BY DATE KREGNIER 2001/10/25 APPROVED BY DATE SMILLER 2010/01/28	TITLE SALES DRAWING FOR HIGH SPEED MEZZANINE PLUG
			ANGULAR ±1/2°			MATERIAL NO. SEE TABLE	MOLEX INCORPORATED DOCUMENT NO. SD-75003-001	SHEET NO. 7 OF 8
			DRAFT WHERE APPLICABLE MUST REMAIN WITHIN DIMENSIONS			THIS DRAWING CONTAINS INFORMATION THAT IS PROPRIETARY TO MOLEX INCORPORATED AND SHOULD NOT BE USED WITHOUT WRITTEN PERMISSION		

PACKAGED IN TAPE AND REEL

NUMBER OF CIRCUITS	NUMBER OF DIFFERENTIAL PAIRS	MATERIAL NUMBER	A	B	C	D	E	F	CARRIER TAPE WIDTH G	PARTS PER REEL
48	24	NOT TOOLED	51.52	38.61	4.50	35.11	44.86	7.25	NOT TOOLED	
48	24	750032105	51.52	38.61	5.50	35.11	44.86	8.25	72	260
48	24	NOT TOOLED	51.52	38.61	6.50	35.11	44.86	9.25	NOT TOOLED	
48	24	NOT TOOLED	51.52	38.61	8.50	35.11	44.86	11.25	NOT TOOLED	
48	24	750032110	51.52	38.61	10.50	35.11	44.86	13.25	72	160
48	24	NOT TOOLED	51.52	38.61	12.50	35.11	44.86	15.25	NOT TOOLED	
72	36	NOT TOOLED	72.58	59.67	4.50	56.17	65.92	7.25	NOT TOOLED	
72	36	750032205	72.58	59.67	5.50	56.17	65.92	8.25	NOT TOOLED	
72	36	NOT TOOLED	72.58	59.67	6.50	56.17	65.92	9.25	NOT TOOLED	
72	36	NOT TOOLED	72.58	59.67	8.50	56.17	65.92	11.25	NOT TOOLED	
72	36	750032210	72.58	59.67	10.50	56.17	65.92	13.25	NOT TOOLED	
72	36	NOT TOOLED	72.58	59.67	12.50	56.17	65.92	15.25	NOT TOOLED	

ADD PKG DETAILS EC NO: UCP2010-1785 DRWN:MSIBARRA 2010/01/22 CHKD:SDANIELLEY 2001/10/25 APPR:SMILLER 2010/01/28	QUALITY SYMBOLS ▽=0 ▽=0 ▽=0	GENERAL TOLERANCES (UNLESS SPECIFIED) <table border="1" style="width: 100%; border-collapse: collapse;"> <tr> <th></th> <th>mm</th> <th>INCH</th> </tr> <tr> <td>4 PLACES</td> <td>± ---</td> <td>± ---</td> </tr> <tr> <td>3 PLACES</td> <td>± ---</td> <td>± ---</td> </tr> <tr> <td>2 PLACES</td> <td>± 0.13</td> <td>± ---</td> </tr> <tr> <td>1 PLACE</td> <td>± 0.25</td> <td>± ---</td> </tr> <tr> <td colspan="3" style="text-align: center;">ANGULAR ±1/2°</td> </tr> </table>		mm	INCH	4 PLACES	± ---	± ---	3 PLACES	± ---	± ---	2 PLACES	± 0.13	± ---	1 PLACE	± 0.25	± ---	ANGULAR ±1/2°			DIMENSION STYLE MM ONLY DRAWN BY DATE KSTILES 2001/10/24 CHECKED BY DATE KREGNIER 2001/10/25 APPROVED BY DATE SMILLER 2010/01/28	SCALE 3:1	DESIGN UNITS METRIC	THIRD ANGLE PROJECTION 	SALES DRAWING FOR HIGH SPEED MEZZANINE PLUG
		mm	INCH																						
	4 PLACES	± ---	± ---																						
	3 PLACES	± ---	± ---																						
2 PLACES	± 0.13	± ---																							
1 PLACE	± 0.25	± ---																							
ANGULAR ±1/2°																									
DRAFT WHERE APPLICABLE MUST REMAIN WITHIN DIMENSIONS						SEE TABLE		MATERIAL NO.	DOCUMENT NO.	SHEET NO.															
THIS DRAWING CONTAINS INFORMATION THAT IS PROPRIETARY TO MOLEX INCORPORATED AND SHOULD NOT BE USED WITHOUT WRITTEN PERMISSION						MOLEX INCORPORATED		SD-75003-001	8 OF 8																
THIS DRAWING CONTAINS INFORMATION THAT IS PROPRIETARY TO MOLEX INCORPORATED AND SHOULD NOT BE USED WITHOUT WRITTEN PERMISSION																									