

DETAIL "I"

OPTIONAL MOUNTING EARS AND RIBS (PRE-BENT EAR SHOWN) SEE DETAIL 3 & 4

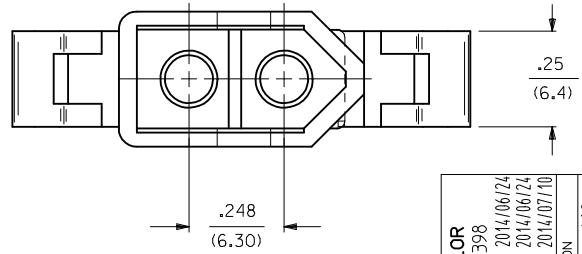

MATERIAL B COLOR EC NO: UCP2014-5398 DRWN:JDOX 2014/06/24 CHKD:HKIPPER 2014/06/24 APPR:FSMITH 2014/07/10	QUALITY SYMBOLS ∇=0 ∇=0 ∇=0	GENERAL TOLERANCES (UNLESS SPECIFIED)		DIMENSION STYLE IN/MM	SCALE 4:1	DESIGN UNITS INCH	THIRD ANGLE PROJECTION	
		4 PLACES ± --- ± ---	DRAWN BY GEP	DATE 8/9/88	TITLE .093/(2.36) HOUSING, PLUG & RECEPTACLE, 2 CKT., .248/(6.30) CTR.			
		3 PLACES ± --- ± .010	CHECKED BY RW	DATE 8/9/88	molex			
		2 PLACES ± 0.25 ± .014	APPROVED BY FSMITH	DATE 2014/07/10	MATERIAL NO. SEE CHART	DOCUMENT NO. SD-1545-*	SHEET NO. 1 OF 3	
1 PLACE ± 0.35 ± ---	ANGULAR ±1/2°		DRAFT WHERE APPLICABLE MUST REMAIN WITHIN DIMENSIONS					
0 PLACE ± --- ± ---	THIS DRAWING CONTAINS INFORMATION THAT IS PROPRIETARY TO MOLEX INCORPORATED AND SHOULD NOT BE USED WITHOUT WRITTEN PERMISSION							

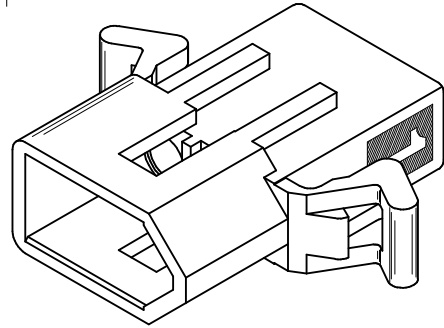
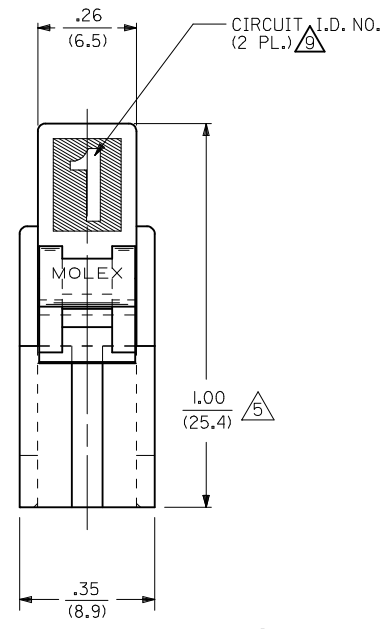
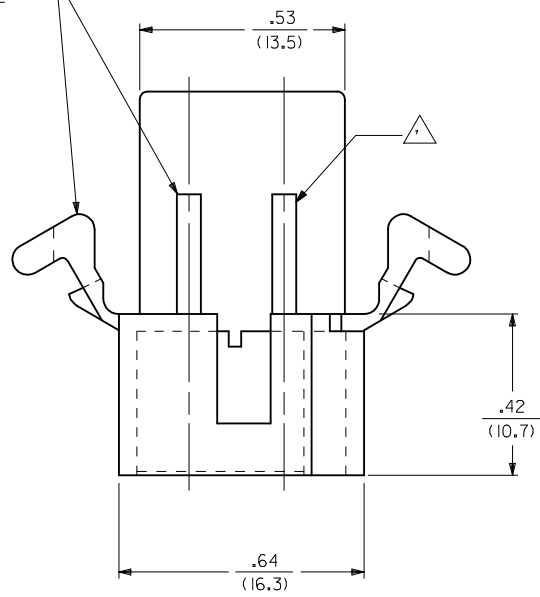
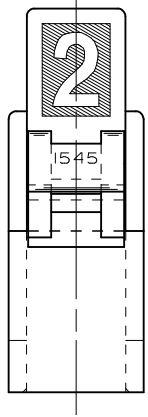
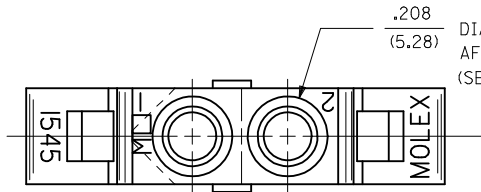

.208
(5.28)
DIA. TERMINAL ENTRY FOR TOOLS BUILT
AFTER FEB. 1985.
(SEE DETAIL 2 FOR OPTIONAL CONFIGURATION.)

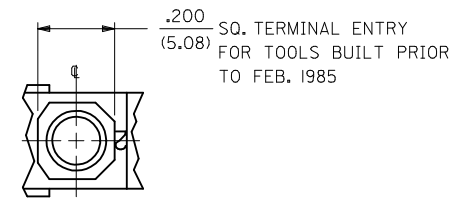

DETAIL "2"

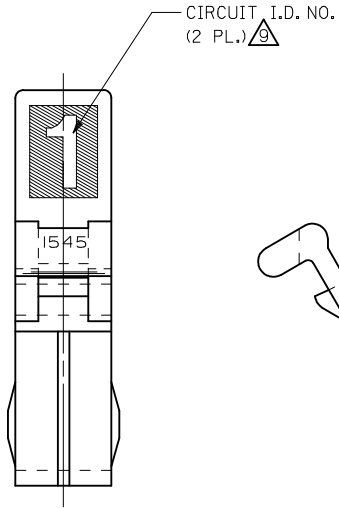

CIRCUIT I.D. NO.
(2 PL.)

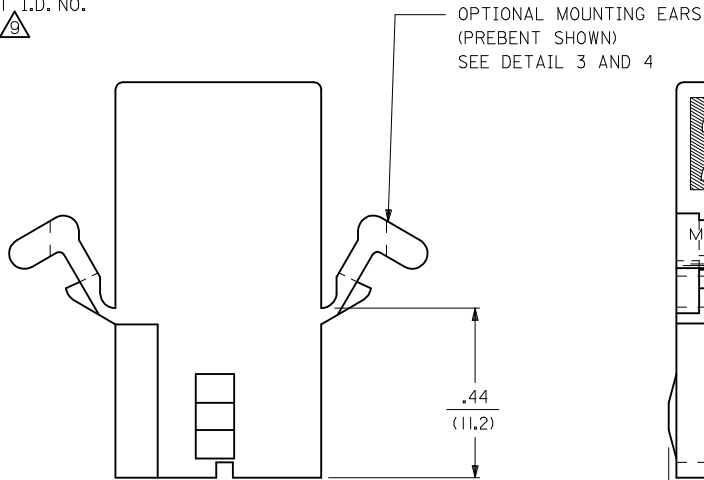

OPTIONAL MOUNTING EARS
(PREBENT SHOWN)
SEE DETAIL 3 AND 4

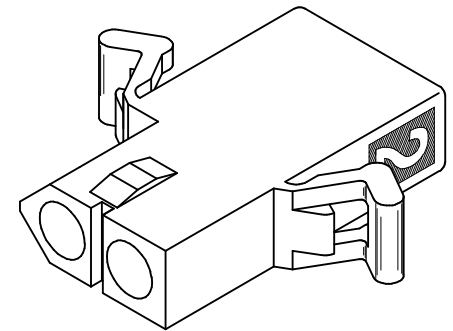
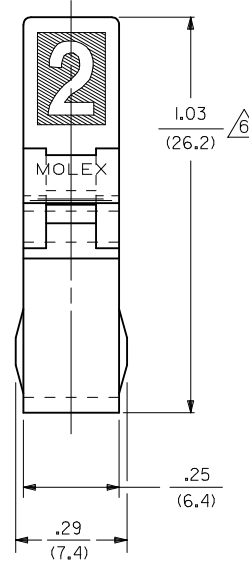

RECEPTACLE

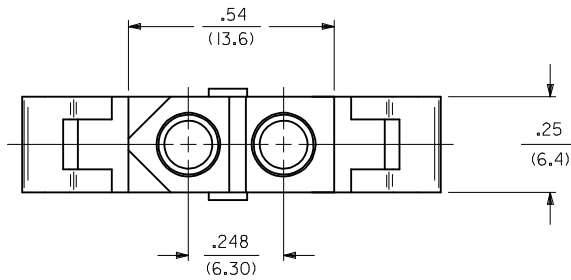

SEE SHEET 1 EC NO: UCP2014-5398 DRWN: DFOX CHKD: HKIPPER APPR: FSMITH	DESCRIPTION 2014/06/24 2014/06/24 2014/07/10	QUALITY SYMBOLS ▽=0 ▽=0 ▽=0	GENERAL TOLERANCES (UNLESS SPECIFIED)		DIMENSION STYLE IN/MM		SCALE 4:1	DESIGN UNITS INCH	THIRD ANGLE PROJECTION	
			mm	INCH	DRAWN BY GEP	DATE 8/9/88	TITLE .093/(2.36) HOUSING, PLUG & RECEPTACLE, 2 CKT., .248/(6.30) CTR.	DOCUMENT NO. SD-1545-*		SHEET NO. 2 OF 3
V1			4 PLACES ± --- ± ---	3 PLACES ± --- ± .010	2 PLACES ± 0.25 ± .014	1 PLACE ± 0.35 ± ---	0 PLACE ± --- ± ---	ANGULAR ±1/2°		THIS DRAWING CONTAINS INFORMATION THAT IS PROPRIETARY TO MOLEX INCORPORATED AND SHOULD NOT BE USED WITHOUT WRITTEN PERMISSION
DRAFT WHERE APPLICABLE MUST REMAIN WITHIN DIMENSIONS			SEE CHART							

PLUG	
PART NO.	ENG. NO.
03-09-2021	I545-P
03-09-2022	I545-P1
03-09-7021	I545-PBK
03-09-7022	I545-P1BK
03-09-2023	I545-P2
03-09-7024	I545-P1RD
03-09-7023	I545-P1BU
50-36-1686	I545-P1-1

RECEPTACLE	
PART NO.	ENG. NO.
03-09-6021	I545-R3BK
03-09-6023	I545-R3RD
03-09-6024	I545-R3BU
03-09-1022	I545-R1
03-09-1023	I545-R2
03-09-6025	I545-R1BU
03-09-1027	I545-R3
50-36-1685	I545-R1-1

LEGEND : PLUG

1545-P*****

OPTIONS: _____

BLANK = WITH STD. EARS
 1 = WITHOUT EARS
 2 = WITH PREBENT EARS

COLOR: BLANK=NATURAL COLOR _____

AM=AMBER BK=BLACK BU=BLUE
 BN=BROWN GY=GRAY GN=GREEN
 OR=ORANGE RD=RED YW=YELLOW

*APPLIES TO MATERIAL A ONLY
 MATERIAL B ONLY AVAILABLE IN BLACK

BLANK = MATERIAL CODE A _____
 1 = MATERIAL CODE B

LEGEND : RECEPTACLE

1545-R*****

BLANK = WITH STD. EARS & RAMPS _____
 1 = WITHOUT EARS, WITH RAMPS
 2 = WITHOUT EARS, WITHOUT RAMPS
 3 = WITH PREBENT EARS & RAMPS

COLOR: BLANK=NATURAL COLOR _____

AM=AMBER BK=BLACK BU=BLUE
 BN=BROWN GY=GRAY GN=GREEN
 OR=ORANGE RD=RED YW=YELLOW

*APPLIES TO MATERIAL A ONLY
 MATERIAL B ONLY AVAILABLE IN BLACK

BLANK = MATERIAL CODE A _____
 1 = MATERIAL CODE B

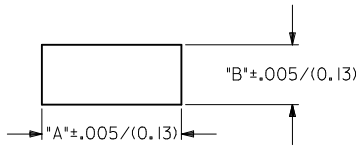
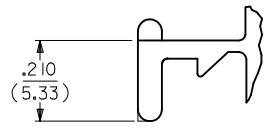
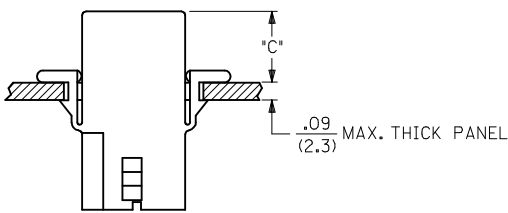

DETAIL 3
 .093/(2.36) STANDARD MOUNTING EAR

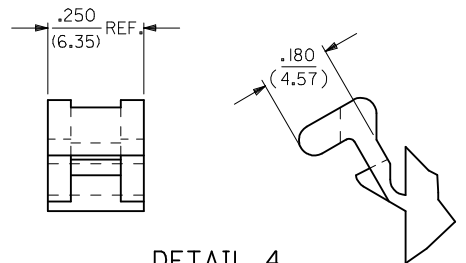

DETAIL 4
 .093/(2.36) PREBENT MOUNTING EAR

RECOMMENDED PANEL OPENING
 (SCALE 2:1)

HOUSING	DIM. "A"	DIM. "B"	DIM. "C" (PREBENT)	DIM. "C" (STD. EAR)
PLUG	.800/(20.32)	.375/(9.53)	.40/(10.2)	.39/(9.9)
RECEPTACLE	.725/(18.42)	.312/(7.92)	.41/(10.4)	.40/(10.2)

NOTES:

- MATERIAL: - A = NYLON, PA66, 94V-2. COLOR: SEE LEGEND.
 B = UL94V-0, PA6 NYLON, GLOW WIRE CAPABLE PER IEC 60335-1. COLOR: BLACK.
- FINISH: NONE.
- PRODUCT SPECIFICATION: PS-02-09.
- PACKAGING INFORMATION: PK-1545-001
- .97/(24.6) REF. FOR TOOLS BUILT PRIOR TO FEB. 1985.
- 1.00/(25.4) REF. FOR TOOLS BUILT PRIOR TO FEB. 1985.
- RIBS ARE PRESENT ONLY ON PARTS WITH MOUNTING EARS.
- EACH TERMINAL POCKET WILL ACCEPT UP TO:
 (2) #18 AWG WIRES HAVING 1/32" THK. INSULATION OR
 (1) #16 AWG WIRE HAVING 1/16" THK. INSULATION OR
 (1) #16 AWG & (1) #18 AWG WIRE HAVING 1/32" THK. INSULATION .
- CIRCUIT I.D. NUMBERS ON SIDE OF HOUSING APPEAR ON PARTS FROM TOOLS BUILT AFTER 11/25/91.
- PARTS CONFORM TO CLASS 'B' REQUIREMENTS OF COSMETIC SPECIFICATION PS-45499-002 EXCEPT MATERIAL OPTION 'B' MEETS CLASS 'C' REQUIREMENTS FOR SINK AND DISCOLORATION.

SEE SHEET 1 EC NO: UCP2014-5398 DRWN:JDFX 2014/06/24 CHKD:HKJPPER 2014/06/24 APPR:FSMITH 2014/07/10 V1	QUALITY SYMBOLS ▽=0 ▽=0 ▽=0	GENERAL TOLERANCES (UNLESS SPECIFIED) <table border="1"> <thead> <tr> <th></th> <th>mm</th> <th>INCH</th> </tr> </thead> <tbody> <tr><td>4 PLACES</td><td>± .010</td><td>± .0004</td></tr> <tr><td>3 PLACES</td><td>± .010</td><td>± .0004</td></tr> <tr><td>2 PLACES</td><td>± 0.25</td><td>± .010</td></tr> <tr><td>1 PLACE</td><td>± 0.35</td><td>± .014</td></tr> <tr><td>0 PLACE</td><td>± .010</td><td>± .0004</td></tr> </tbody> </table>		mm	INCH	4 PLACES	± .010	± .0004	3 PLACES	± .010	± .0004	2 PLACES	± 0.25	± .010	1 PLACE	± 0.35	± .014	0 PLACE	± .010	± .0004	DIMENSION STYLE IN/MM	SCALE 4:1	DESIGN UNITS INCH	THIRD ANGLE PROJECTION
				mm	INCH																			
			4 PLACES	± .010	± .0004																			
			3 PLACES	± .010	± .0004																			
2 PLACES	± 0.25	± .010																						
1 PLACE	± 0.35	± .014																						
0 PLACE	± .010	± .0004																						
DRAWN BY DATE GEP 8/9/88		CHECKED BY DATE RW 8/9/88		.093/(2.36) HOUSING, PLUG & RECEPTACLE, 2 CKT., .248/(6.30) CTR.																				
APPROVED BY DATE FSMITH 2014/07/10		MATERIAL NO. SEE CHART					DOCUMENT NO. SD-1545-*	SHEET NO. 3 OF 3																
DRAFT WHERE APPLICABLE MUST REMAIN WITHIN DIMENSIONS																								
THIS DRAWING CONTAINS INFORMATION THAT IS PROPRIETARY TO MOLEX INCORPORATED AND SHOULD NOT BE USED WITHOUT WRITTEN PERMISSION																								