

NON	20.55	19.5	21.45	55560-0801	80
10,21	15.55	14.5	16.45	-0601	60
2,4,8,10,16,18,22,24	13.05	12.0	13.95	-0501	50
2,3,5,6,8,9,12,13,15,16,18,19	10.55	9.5	11.45	-0401	40
2,3,4,5,7,8,9,10,11,13,14,15,16	9.05	8.0	9.95	-0341	34
ALL	8.05	7.0	8.95	-0301	30
	6.55	5.5	7.45	-0241	24
	6.05	5.0	6.95	-0221	22
	5.55	4.5	6.45	-0201	20
4.55	3.5	5.45	55560-0161	16	
LOCK POSITION	C	B	A	MATERIAL NO.	極数 CIRCUIT

REVISED EC NO: J2012-0135 DRWN: YON002 CHKD: TASAKAWA APPR: MSASAO 2011/07/01 2011/07/01 2011/07/29	GENERAL TOLERANCES (UNLESS SPECIFIED)		DIMENSION STYLE MM ONLY		SCALE ---	DESIGN UNITS METRIC	THIRD ANGLE PROJECTION
	10 UNDER	±0.20	DRAWN BY SAIHARA	DATE 2003/03/31	TITLE 0.5 B-TO-B CONN PLUG ASSY (HGT=1.5)		
	10 OVER 30 UNDER	±0.25	CHECKED BY MSASAO	DATE 2003/03/31	MOLEX INCORPORATED		
	30 OVER	±0.30	APPROVED BY MSASAO	DATE 2003/03/31	MATERIAL NO. SEE CHART	DOCUMENT NO. SD-55560-006	SHEET NO. 1 OF 2
	ANGULAR ±3 °	THIS DRAWING CONTAINS INFORMATION THAT IS PROPRIETARY TO MOLEX INCORPORATED AND SHOULD NOT BE USED WITHOUT WRITTEN PERMISSION					
	DRAFT WHERE APPLICABLE MUST REMAIN WITHIN DIMENSIONS						

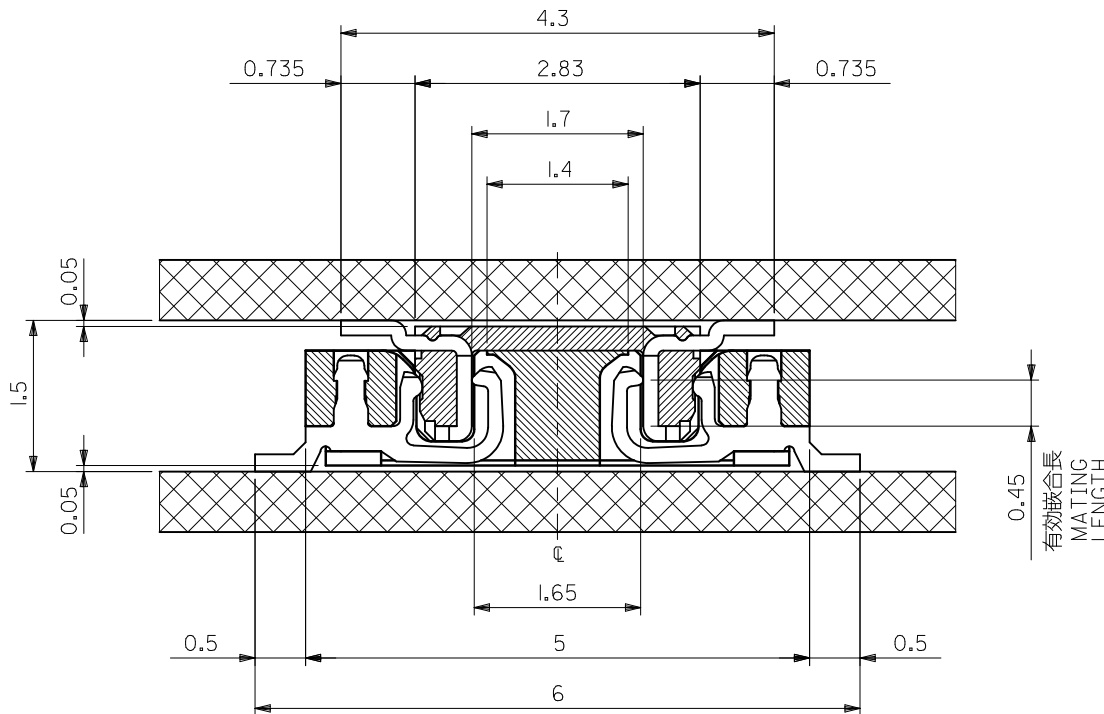

嵌合断面図 (参考)
MATED DRAWING (REF.)

注記 NOTES:

1. 使用材料 MATERIAL
 ウェハー: 液晶ポリマー ガラス充填 ,UL94V-0(黒)
 WAFER : LIQUID CRYSTAL POLYMER
 (GLASS FILLED), UL94V-0 (COLOR: BLACK)
 ピン : 黄銅 (t=0.15)
 PIN : BRASS (t=0.15)
2. メッキ仕様 PLATING
 金メッキ 0.25 MICROMETER MINIMUM (コンタクト部)
 GOLD 0.25 MICROMETER MINIMUM (CONTACT AREA).
 金メッキ 0.4 MICROMETER MAXIMUM (テール部)
 GOLD 0.4 MICROMETER MAXIMUM (TAIL AREA).
 下地メッキ: ニッケルメッキ 1.5 MICROMETER MINIMUM
 UNDER PLATING : NICKEL 1.5 MICROMETER MINIMUM.
3. (全極数/2) = 偶数の場合に適用。
 APPLY FOR (CIRCUIT/2)=EVEN.
4. 嵌合相手: 54722 シリーズ, 54037 シリーズ
 MATE WITH : 54722 SERIES, 54037 SERIES.
5. テール平坦度は、0.1 MAXIMUM
 TAIL COPLANARITY TO BE 0.1 MAXIMUM.

REVISED EC NO: J2012-0135 DRWN: YON002 CHKD: TASAKAWA APPR: MSASAO	2011/07/01 2011/07/01 2011/07/29	DESCRIPTION REV	GENERAL TOLERANCES (UNLESS SPECIFIED)		DIMENSION STYLE MM ONLY		SCALE ---	DESIGN UNITS METRIC	THIRD ANGLE PROJECTION	
			10 UNDER	± 0.20	DRAWN BY SAIHARA	DATE 2000/10/05	TITLE 0.5 B-T-O-B CONN PLUG ASSY (HGT=1.5)			
			10 OVER 30 UNDER	± 0.25	CHECKED BY MSASAO	DATE 2003/03/31	MOLEX INCORPORATED			
			30 OVER	± 0.30	APPROVED BY MSASAO	DATE 2003/03/31	MATERIAL NO. SEE SHEET 1	DOCUMENT NO. SD-55560-006	SHEET NO. 2 OF 2	
			ANGULAR ±3 ° DRAFT WHERE APPLICABLE MUST REMAIN WITHIN DIMENSIONS		THIS DRAWING CONTAINS INFORMATION THAT IS PROPRIETARY TO MOLEX INCORPORATED AND SHOULD NOT BE USED WITHOUT WRITTEN PERMISSION					

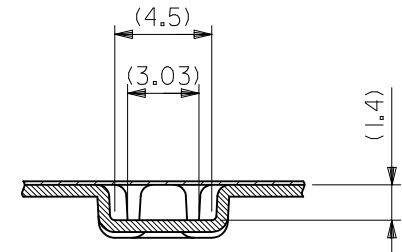
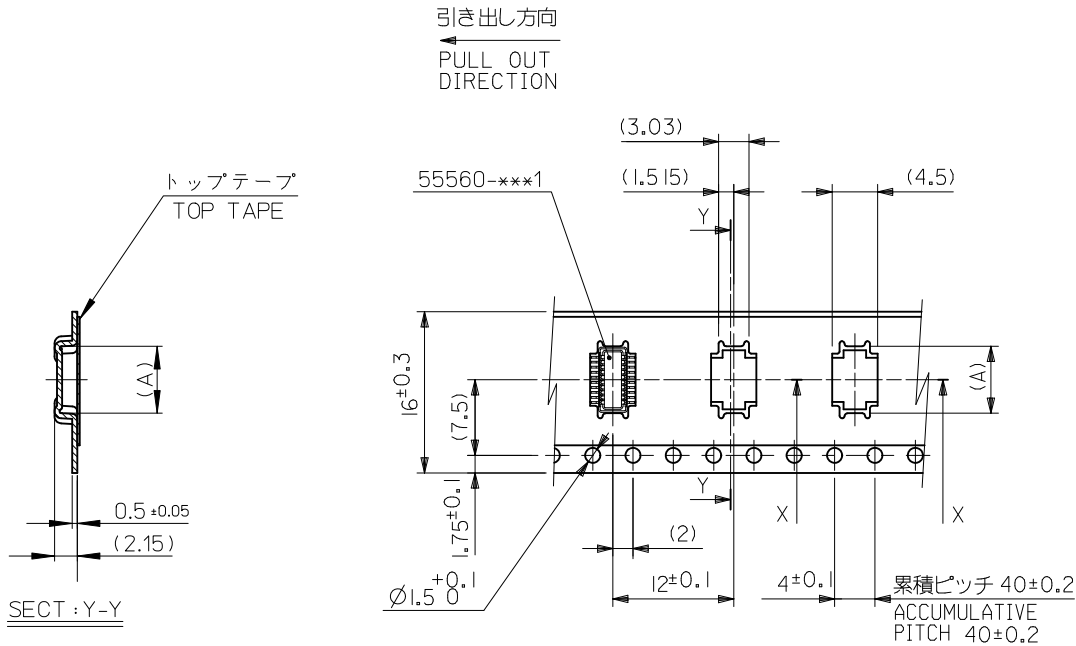

SECTION X-X
SCALE 5:1

16mm幅キャリアテープ
16mm WIDTH CARRIER TAPE

16	17.5	6.65	55560-0207	55560-***7	20
キャリアテープ幅 CARRIER TAPE WIDTH	B	(A)	MATERIAL No.	MODEL No.	極数 CIRCUIT

REVISED EC NO: J2010-1529 DRWN: YON002 2010/01/28 CHKD: SMARUYAMA 2010/02/01 APPR: MSASAO 2010/02/01	GENERAL TOLERANCES (UNLESS SPECIFIED)		DIMENSION STYLE MM ONLY		SCALE ---	DESIGN UNITS METRIC	THIRD ANGLE PROJECTION
	10 UNDER	±0.2	DRAWN BY S. AIHARA	DATE '00/10/06	TITLE 0.5 B-T0-B PLUG ASSY (HGT=1.5) EMBSTP PKG (SHEET 2 OF 5)		
	10 OVER 30 UNDER	±0.25	CHECKED BY M. SASAO	DATE '03/03/31	MOLEX INCORPORATED		
	30 OVER	±0.3	APPROVED BY M. SASAO	DATE '03/03/31	MATERIAL NO. SEE CHART	DOCUMENT NO. SD-55560-007	SHEET NO. 2 OF 5
J	DESCRIPTION ANGULAR ±3 ° DRAFT WHERE APPLICABLE MUST REMAIN WITHIN DIMENSIONS	THIS DRAWING CONTAINS INFORMATION THAT IS PROPRIETARY TO MOLEX INCORPORATED AND SHOULD NOT BE USED WITHOUT WRITTEN PERMISSION					

10 9 8 7 6 5 4 3 2 1

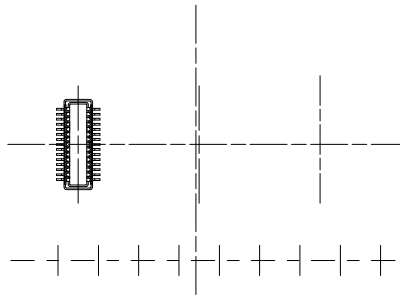
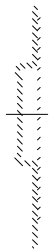

REV	DESCRPTI	GENERAL TOLERANCES (UNLESS SPECIFIED)		DIMENSION STYLE MM ONLY		SCALE ---	DESIGN UNITS METRIC	THIRD ANGLE PROJECTION	
		10 UNDER	± 0.2	DRAWN BY S. AIHARA	DATE '00/10/06	TITLE 0.5 B-T0-B PLUG ASSY (HGT=1.5) EMBSTP PKG (SHEET 3 OF 5)			
		10 OVER 30 UNDER	± 0.25	CHECKED BY M. SASAO	DATE '03/03/31				
		30 OVER	± 0.3	APPROVED BY M. SASAO	DATE '03/03/31	DOCUMENT NO. SD-55560-007		SHEET NO. 3 OF 5	
		ANGULAR ± 3 °		MATERIAL NO.					
DRAFT WHERE APPLICABLE MUST REMAIN WITHIN DIMENSIONS		SIZE A3	THIS DRAWING CONTAINS INFORMATION THAT IS PROPRIETARY TO MOLEX INCORPORATED AND SHOULD NOT BE USED WITHOUT WRITTEN PERMISSION						