

CIRCUIT SIZE	DIM. A	DIM. B	DIM. C	DIM. D
20	13.90 .547	9.00 .354	12.58 .495	12.40 .488
30	18.90 .744	14.00 .551	17.58 .692	17.40 .685
40	23.90 .941	19.00 .748	22.58 .889	22.40 .882
50	28.90 1.138	24.00 .945	27.58 1.086	27.40 1.079
60	33.90 1.335	29.00 1.142	32.58 1.283	32.40 1.276
64	35.90 1.413	31.00 1.220	34.58 1.361	34.40 1.354
70	38.90 1.531	34.00 1.339	37.58 1.480	37.40 1.472
80	43.90 1.728	39.00 1.535	42.58 1.676	42.40 1.669
84	45.90 1.807	41.00 1.614	44.58 1.755	44.40 1.748
90	48.90 1.925	44.00 1.732	47.58 1.873	47.40 1.866
100	53.90 2.122	49.00 1.929	52.58 2.070	52.40 2.063
110	58.90 2.319	54.00 2.126	57.58 2.267	57.40 2.260
120	63.90 2.516	59.00 2.323	62.58 2.464	62.40 2.457

**NOTES:**

- HOUSING MATERIAL: G.F. THERMOPLASTIC; UL RATING: 94V-0; COLOR: WHITE  
NOTE: HOUSING COLOR FOR -1664 (ONLY) IS BLACK.  
TERMINAL MATERIAL: PHOSPHOR BRONZE; 0.205/.0080 THICK  
VACUUM CAP MATERIAL: STAINLESS STEEL; 0.255/.0100 THICK
- PLATING FINISHES: SEE SHEET 2.
- THIS PART, WHEN MATED WITH MOLEX 1.0mm RECEPTACLE CONNECTOR SERIES 71439, CONFORMS TO MOLEX PRODUCT SPECIFICATION PS-71436-9999. REFER TO CHART ON SHEET 2 FOR MATED STACK HEIGHTS FOR THIS PLUG.
- PACKAGING SPECIFICATIONS: REFER TO CHART ON SHEET 2.
- PEGS ARE OPTIONAL. REFER TO CHART ON SHEET 2.
- VACUUM PICK & PLACE CAP IS OPTIONAL. REFER TO CHART ON SHEET 2.
- THIS PART CONFORMS TO EIA STANDARD 700 AAAB FOR 1.0mm TWO-PART CONNECTORS FOR USE WITH PARALLEL PRINTED BOARDS.
- COPLANARITY OF SMT TAILS: 0.10/.004 MAX.
- 64-CIRCUIT PLUG ASSEMBLY WITH PEGS AND VACUUM CAP SHOWN FOR ILLUSTRATION PURPOSES ONLY.
- DIMENSIONS ARE IN mm/In. INCH DIMENSIONS SHOWN FOR REFERENCE ONLY.
- DATE CODE STAMP IS WEEK, YEAR LOCATED APPROXIMATELY WHERE SHOWN.

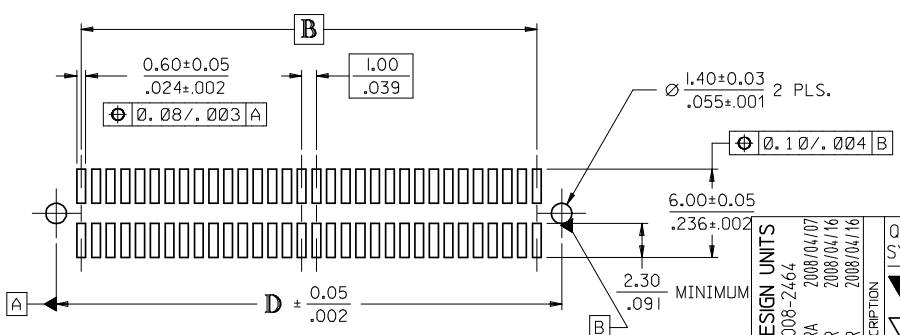
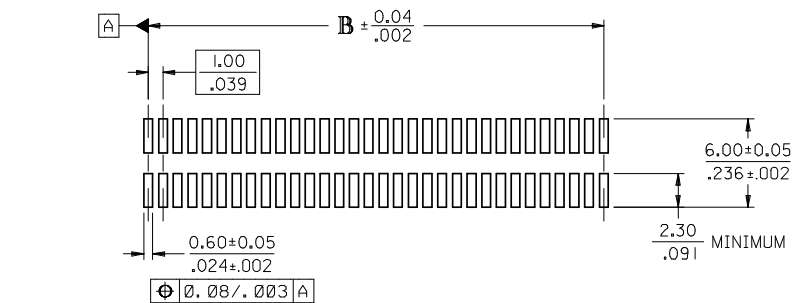

**RECOMMENDED PCB LAYOUT  
(WITH AND WITHOUT PEGS)**

RECOMMENDED PCB THICKNESS:  $1.00 \pm 0.10 / .039 \pm .004$  MINIMUM

REV	DESCRIPTION
0	INITIAL RELEASE
1	REVISION

QUALITY SYMBOLS	GENERAL TOLERANCES (UNLESS SPECIFIED)
$\nabla=0$	mm
$\nabla=0$	INCH
	4 PLACES $\pm .005$
	3 PLACES $\pm .005$
	2 PLACES $\pm 0.13$ $\pm 0.01$
	1 PLACE $\pm 0.25$ $\pm .005$
	ANGULAR $\pm 1/2^\circ$

DESIGN UNITS	SCALE	THIRD ANGLE PROJECTION
METRIC	4:1	

DATE	TITLE
1995/03/23	SALES ASSY, 1.0MM BOARD TO BOARD PLUG CONNECTOR 3.30/130 STACK HEIGHT
1995/03/23	MOLEX MOLEX INCORPORATED
1995/03/23	SDA-71436-1***

SHT	REV
2	I
1	J

DRAFT WHERE APPLICABLE MUST REMAIN WITHIN DIMENSIONS

SEE TABLE

THIS DRAWING CONTAINS INFORMATION THAT IS PROPRIETARY TO MOLEX INCORPORATED AND SHOULD NOT BE USED WITHOUT WRITTEN PERMISSION

**STANDARD**

CIRCUIT SIZE	PLUG ASSEMBLY ITEM NUMBER	PEGS	CONTACT PLATING SEE PLATING NOTES	PICK & PLACE CAP	PACKAGING SPEC. NUMBER	PACKAGING TYPE
64	71436-1164	YES	30 GOLD	NO	PK-70873-0607	TUBE
64	71436-1364	YES	30 GOLD	YES	PK-70873-0607	TUBE
64	71436-1464	YES	30 GOLD	YES	PK-70873-063	TAPE & REEL
64	71436-1564	NO	30 GOLD	NO	PK-70873-0606	TUBE
64	71436-1664	NO	30 GOLD	YES MATTE FINISH	PK-70873-063	TAPE & REEL
64	71436-1764	NO	30 GOLD	YES	PK-70873-0606	TUBE
64	71436-1864	NO	30 GOLD	YES	PK-70873-063	TAPE & REEL
64	71436-1264	YES	50 GOLD	NO	PK-70873-0607	TUBE
64	71436-1064	NO	50 GOLD	NO	PK-70873-0607	TUBE

RECOMMENDED PLUG/RECEPTACLE COMBINATION FOR MATED STACK HEIGHT PER EIA STANDARD 700 AAAB

MATED STACK HEIGHT	RECEPTACLE HEIGHT	RECEPTACLE SERIES NO.	PLUG HEIGHT	PLUG SERIES NO.
9.00/.354	5.30/.209	71439-0***	3.30/.130	71436-1***
11.00/.433	7.30/.287	71439-1***	3.30/.130	71436-1***
14.00/.551	10.30/.406	71439-3***	3.30/.130	71436-1***

PLATING NOTES:

30 GOLD: 0.76 MICROMETERS(30 MICRONCHES) MINIMUM SELECTIVE GOLD (Au) IN THE CONTACT AREA  
1.88 MICROMETERS(75 MICRONCHES) MINIMUM SELECTIVE TIN (Sn) IN THE PC TAIL AREA  
NICKEL UNDERPLATE OVERALL

50 GOLD: 1.27 MICROMETERS(50 MICRONCHES) MINIMUM SELECTIVE GOLD (Au) IN THE CONTACT AREA  
1.88 MICROMETERS(75 MICRONCHES) MINIMUM SELECTIVE TIN (Sn) IN THE PC TAIL AREA  
NICKEL UNDERPLATE OVERALL

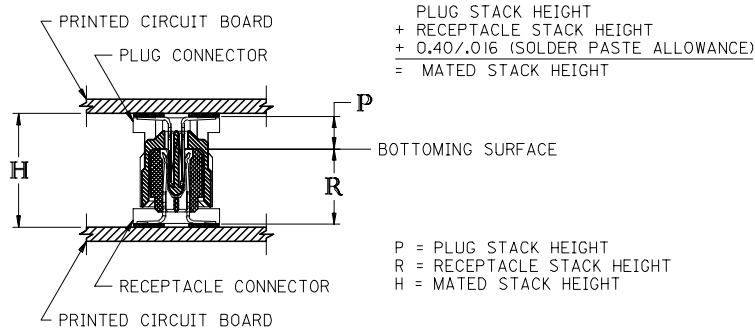

ADD 71436-1064/-1264 EC NO: UCP2007-2420 DRAWN BY: BARRA 2007/05/08 CHKD: MORGAN 2007/05/17 APPR: MILLER 2007/05/18 REV:	QUALITY SYMBOLS	GENERAL TOLERANCES (UNLESS SPECIFIED)	DIMENSION STYLE	SCALE	DESIGN UNITS	THIRD ANGLE PROJECTION	
	$\nabla=0$ $\nabla=0$	mm INCH	MM/IN	---	INCH		
		4 PLACES ± --- ± ---	DRAWN BY DATE	REED 1995/03/23	TITLE	SALES ASSY, 1.0MM BOARD TO BOARD PLUG CONNECTOR 3.30/.130 STACK HEIGHT	
		3 PLACES ± --- ± ---	CHECKED BY DATE	REED 1995/03/23	MATERIAL NO.	MOLEX INCORPORATED	
	2 PLACES ± --- ± ---	APPROVED BY DATE	BIXLER 1995/03/23	DOCUMENT NO.	SDA-71436-1***		
	1 PLACE ± --- ± ---	ANGULAR ±1/2°		SHEET NO.	2 OF 2		
DRAFT WHERE APPLICABLE MUST REMAIN WITHIN DIMENSIONS		SEE TABLE		THIS DRAWING CONTAINS INFORMATION THAT IS PROPRIETARY TO MOLEX INCORPORATED AND SHOULD NOT BE USED WITHOUT WRITTEN PERMISSION			