

注記 NOTES:

1. 使用材料 MATERIAL
 ウエハー: 液晶ポリマー (LCP) ガラス充填 UL94V-0 (黒)
 WAFER: LIQUID CRYSTAL POLYMER (GLASS FILLED) UL94V-0 (COLOR: BLACK)
 ピン: 黄銅 (t=0.12)
 PIN: BRASS (t=0.12)
 金具: リン青銅 (t=0.2)
 FITTING NAIL: PHOSPHOR BRONZE (t=0.2)
2. メッキ仕様 PLATING
 ピン PIN
 金メッキ 0.2 マイクロメートル以上 (コンタクト部)
 GOLD 0.2MICROMETER MINIMUM (CONTACT AREA)
 金メッキ 0.4 マイクロメートル以下 (テール部)
 GOLD 0.4MICROMETER MAXIMUM (TAIL AREA)
 下地メッキ: ニッケルメッキ 1.5 マイクロメートル以上
 UNDER PLATING: NICKEL 1.5MICROMETER MINIMUM
 金具 FITTING NAIL
 錫メッキ 1.0 マイクロメートル以上
 TIN PLATING 1.0MICROMETER MINIMUM
 下地メッキ: ニッケルメッキ 1.0 マイクロメートル以上
 UNDER PLATING: NICKEL 1.0MICROMETER MINIMUM

- △ (全極数/2) = 偶数の場合に適用。
 APPLY FOR (CIRCUIT/2)=EVEN.
4. 嵌合相手: 51338シリーズ
 MATE WITH: 51338 SERIES.
 5. テール平坦度は、0.08以下
 テール及び金具の平坦度は、0.1以下
 TAIL COPLANARITY TO BE 0.08 MAXIMUM
 TAIL AND FITTING NAIL COPLANARITY TO BE 0.1 MAXIMUM
 6. 本製品は 55909-***3 の鉛フリー品である。
 THIS PRODUCT IS LEAD FREE OF 55909-***3.
 7. ELV及びRoHS適合品
 ELV AND RoHS COMPLIANT.

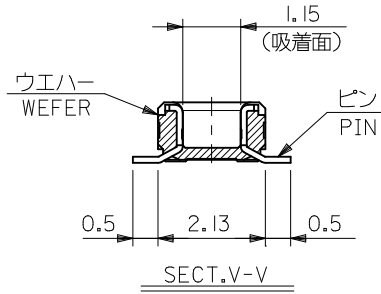
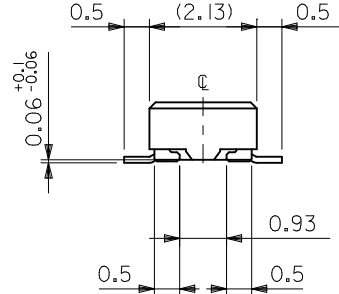

14.0	12.4	14.8	55909-6472	64
12.0	10.4	12.8	55909-5472	54
10.0	8.4	10.8	55909-4472	44
3.2	1.6	4.0	55909-9872	10
C	B	A	EMBOSSED TAPE PKG ORDER No. オーダー番号	極数 CIRCUIT

REVISED EC NO: J2010-2586 DRWN: YON002 CHKD: S. MARUYAMA APPR: MSASAO	DESCRIPTION REV	GENERAL TOLERANCES (UNLESS SPECIFIED)		DIMENSION STYLE MM ONLY		SCALE ---		DESIGN UNITS METRIC		THIRD ANGLE PROJECTION	
		10 UNDER	±0.2	DRAWN BY Y. NUKANOBU	DATE 2010/01/25	TITLE 0.4 B-TO-B CONN. PLUG ASSY (HGT=1.5) WITH NAIL					
		10 OVER 30 UNDER	±0.25	CHECKED BY S. MARUYAMA	DATE 2010/01/25	MOLEX INCORPORATED					
		30 OVER	±0.3	APPROVED BY M. SASAO	DATE 2010/01/25	DOCUMENT NO. SD-55909-005					
ANGULAR ±3 °		DRAFT WHERE APPLICABLE MUST REMAIN WITHIN DIMENSIONS		MATERIAL NO. SEE TABLE		SHEET NO. 1 OF 2		THIS DRAWING CONTAINS INFORMATION THAT IS PROPRIETARY TO MOLEX INCORPORATED AND SHOULD NOT BE USED WITHOUT WRITTEN PERMISSION			

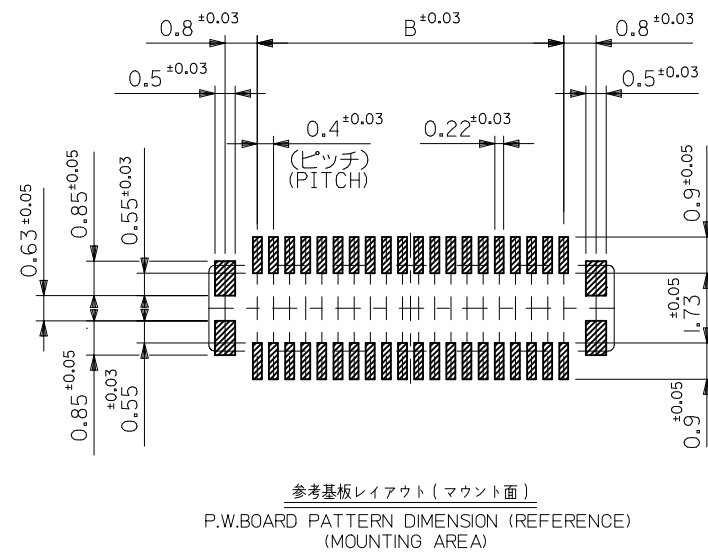
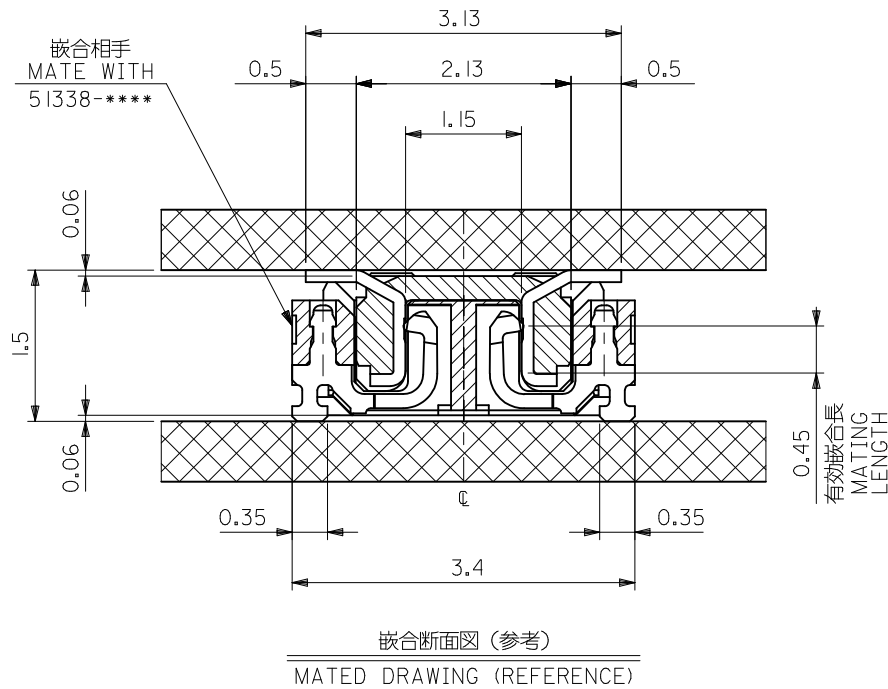

CONNECTOR SERIES No.: 55909-**73

REVISED EC NO: J2010-2586 DRWN: YON002 2010/06/24 CHK'D: S. MARUYAMA 2010/06/29 APPR: MSASAO 2010/06/29	GENERAL TOLERANCES (UNLESS SPECIFIED)		DIMENSION STYLE MM ONLY	SCALE ---	DESIGN UNITS METRIC	THIRD ANGLE PROJECTION
	10 UNDER	±0.2	DRAWN BY Y. NUKANOBU	DATE 2010/01/25	TITLE 0.4 B-TO-B CONN. PLUG ASSY (HGT=1.5) WITH NAIL	
	10 OVER 30 UNDER	±0.25	CHECKED BY S. MARUYAMA	DATE 2010/01/25	MOLEX INCORPORATED	
	30 OVER	±0.3	APPROVED BY M. SASAO	DATE 2010/01/25	DOCUMENT NO. SD-55909-005	SHEET NO. 2 OF 2
	ANGULAR ±3 ° DRAFT WHERE APPLICABLE MUST REMAIN WITHIN DIMENSIONS		SIZE A3	THIS DRAWING CONTAINS INFORMATION THAT IS PROPRIETARY TO MOLEX INCORPORATED AND SHOULD NOT BE USED WITHOUT WRITTEN PERMISSION		

NOTES

- 製品詳細寸法については、SD-55909-005 を参照下さい。
RE DETAILED DIMENSION, SEE PRODUCT DRAWING SD-55909-005.
- 梱包数量：2500個/リール
NUMBER OF CONNECTORS : 2500PCS/REEL
- リードテープ長さ LEAD TAPE LENGTH

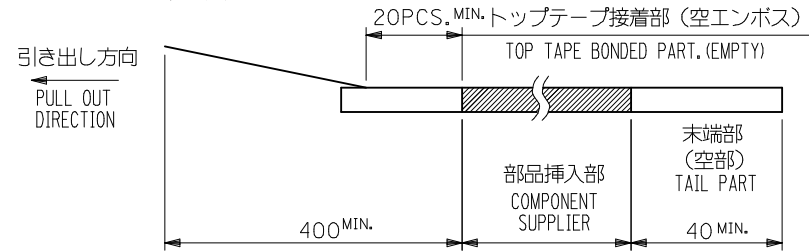
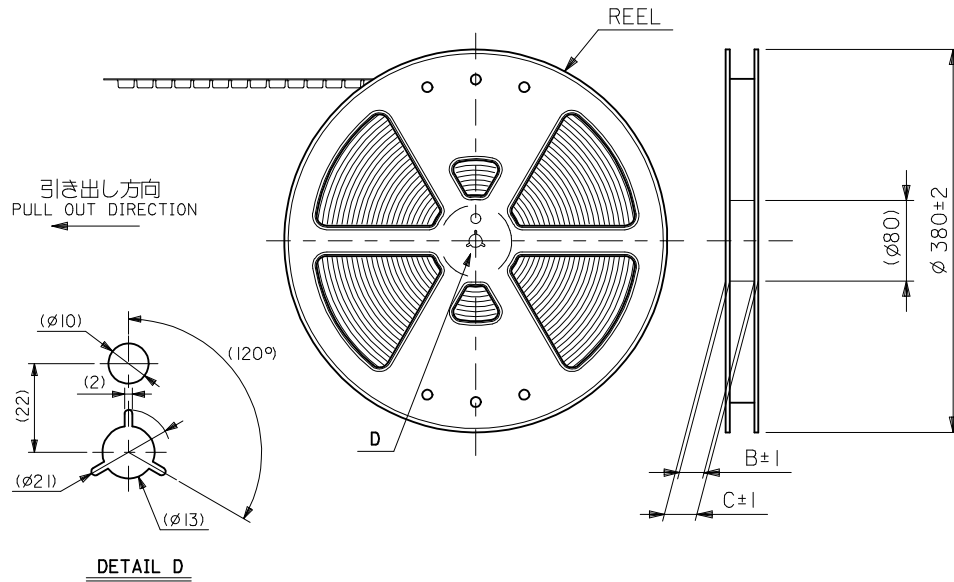

4.材料

- キャリアテープ : PS
- トップテープ : PS, OTHER
- リール : PS<リサイクル材を含む>

MATERIAL

- CARRIER TAPE : PS
- TOP TAPE : PS, OTHER
- REEL : PS <RECYCLE MATERIAL CONTAINED>

5.ELV 及び RoHS 適合品。

ELV AND RoHS COMPLIANT.

REVISED EC NO.: J2015-0987 DRWN:KMIYAHARA 2015/01/28 CHKD:KTAKAKO3 2015/09/07 APPR:KMORIKAWA 2015/09/11	GENERAL TOLERANCES (UNLESS SPECIFIED)		DIMENSION STYLE MM ONLY		SCALE ---	DESIGN UNITS METRIC	MODEL NO. 55909-**-72	THIRD ANGLE PROJECTION
	0.25 UNDER	UNDER	±0.03	DRAWN BY YON002	DATE 2010/06/23	TITLE 0.4 B-TO-B CONN PLUG ASSY(HGT=1.5) EMBSTP PKG		
	0.25 OVER	0.5 UNDER	±0.05	CHECKED BY		DATE		
	0.5 OVER	1.0 UNDER	±0.1	APPROVED BY MSASAO		DATE 2010/06/29		
	1.0 OVER	10 UNDER	±0.2	MATERIAL NO.		SEE CHART	DOCUMENT NO. SD-55909-006	SHEET NO. 1 OF 3
10 OVER	30 UNDER	±0.25	DRAFT WHERE APPLICABLE MUST REMAIN WITHIN DIMENSIONS		THIS DRAWING CONTAINS INFORMATION THAT IS PROPRIETARY TO MOLEX INCORPORATED AND SHOULD NOT BE USED WITHOUT WRITTEN PERMISSION			
30 OVER		±0.3	SIZE A3					
ANGULAR	±3 °							

引き出し方向
PULL OUT DIRECTION

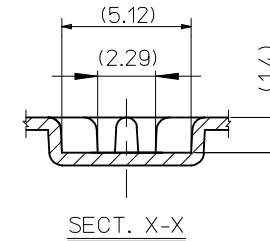
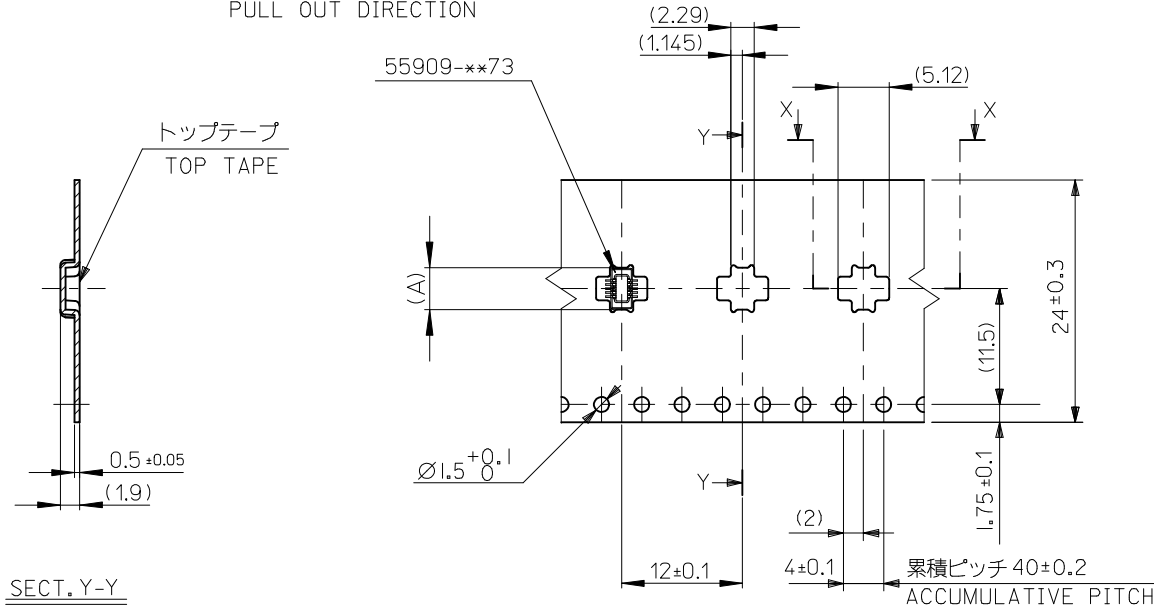

SECT. Y-Y

注記) 製品がポケット内に問題なく収まること。
NOTE. Pocket should contain product smoothly.

24	29.4	25.4	4.16	55909-9872	10
キャリアテープ幅 CARRIER TAPE WIDTH	C	B	(A)	オーダー番号 ORDER NO.	極数 CIRCUITS

SEE SHEET 1 OF 3 EC NO.: J2015-0987 DRW: KMIYAHARA 2015/01/28 CHK: DKTANAKA03 2015/09/07 APPR: KMORIKAWA 2015/09/11	GENERAL TOLERANCES (UNLESS SPECIFIED)			DIMENSION STYLE MM ONLY		SCALE ---	DESIGN UNITS METRIC	55909-**72		MODEL NO.
	0.25 UNDER	UNDER	± 0.03	DRAWN BY	DATE	TITLE				
	0.25 OVER	0.5 UNDER	± 0.05	YON002	2010/06/23	0.4 B-T0-B CONN PLUG ASSY(HGT=1.5) EMBSTP PKG				
	0.5 OVER	1.0 UNDER	± 0.1	CHECKED BY	DATE					
	1.0 OVER	10 UNDER	± 0.2	APPROVED BY	DATE					
10 OVER	30 UNDER	± 0.25	MSASAO	2010/06/29	MATERIAL NO.		DOCUMENT NO.		SHEET NO.	
30 OVER		± 0.3	SEE CHART			SD-55909-006		2 OF 3		
ANGULAR	± 3 °		THIS DRAWING CONTAINS INFORMATION THAT IS PROPRIETARY TO MOLEX INCORPORATED AND SHOULD NOT BE USED WITHOUT WRITTEN PERMISSION							
DRAFT WHERE APPLICABLE MUST REMAIN WITHIN DIMENSIONS										

引き出し方向
PULL OUT DIRECTION

トップテープ
TOP TAPE

55909-**73

0.5±0.05
(2.6)

SECT. Y-Y

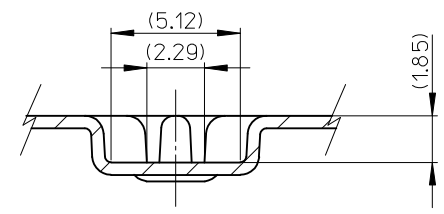
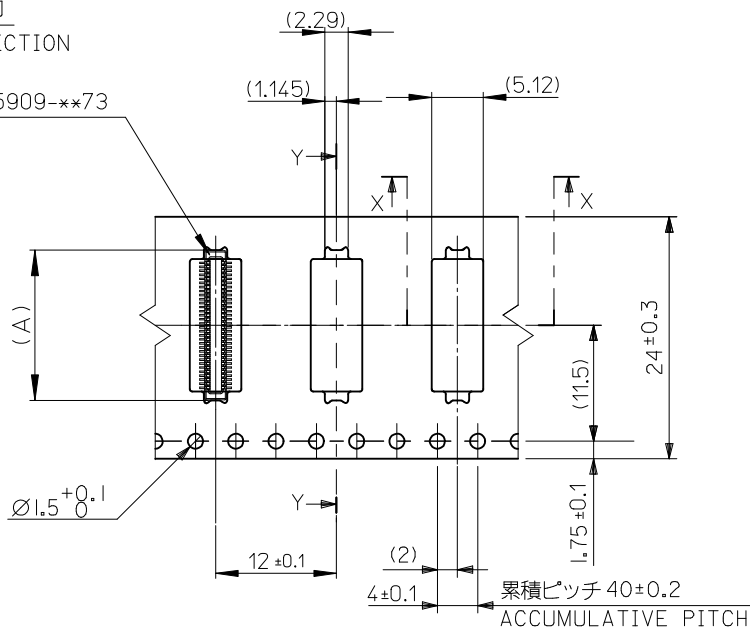

SECT. X-X

注記) 製品がポケットに問題なく収まること。
NOTE. Pocket should contain product smoothly.

24	29.4	25.4	14.96	55909-6472	64
			12.96	55909-5472	54
			10.96	55909-4472	44
キャリアテープ幅 CARRIER TAPE WIDTH	C	B	(A)	オーダー番号 ORDER NO.	極数 CIRCUITS

SEE SHEET 1 OF 3 EC NO.: J2015-0987 DRW: KMIYAHARA 2015/01/28 CHK: DKTANAKA03 2015/09/07 APPR: KMORIKAWA 2015/09/11	GENERAL TOLERANCES (UNLESS SPECIFIED)			DIMENSION STYLE MM ONLY		SCALE ---	DESIGN UNITS METRIC	MODEL NO. 55909-**72		
	0.25 UNDER	UNDER	±0.03	DRAWN BY YON002	DATE 2010/06/23	TITLE 0.4 B-T0-B CONN PLUG ASSY(HGT=1.5) EMBSTP PKG				
	0.25 OVER	0.5 UNDER	±0.05	CHECKED BY	DATE					
	0.5 OVER	1.0 UNDER	±0.1	APPROVED BY MSASAO		DATE 2010/06/29	DOCUMENT NO. SD-55909-006			
	1.0 OVER	30 UNDER	±0.2	MATERIAL NO.		SEE CHART				
30 OVER		±0.3	SIZE A3		THIS DRAWING CONTAINS INFORMATION THAT IS PROPRIETARY TO MOLEX INCORPORATED AND SHOULD NOT BE USED WITHOUT WRITTEN PERMISSION					
ANGULAR ±3 °			DRAFT WHERE APPLICABLE MUST REMAIN WITHIN DIMENSIONS		SHEET NO. 3 OF 3					