

- NOTES:
- MATERIAL -  
HOUSING: LIQUID CRYSTAL POLYMER, GLASS FILLED,  
UL-94V-0, COLOR: BLACK  
TERMINALS: PHOSPHOR BRONZE  
LATCHES: STAINLESS STEEL
  - FINISHES -  
TERMINALS: CONTACT AREA - SELECTIVE GOLD OVER  
PALLADIUM NICKEL OVER NICKEL  
SOLDER AREA - SELECTIVE TIN OVER NICKEL  
LATCHES: OVERALL - TIN OVER NICKEL
  - PRODUCT SPECIFICATION - PS-44828-001  
APPLICATION SPECIFICATION: AS-44828-001
  - PACKAGING: MOLEX SPECIFICATION - PK-45560-300.
  - RECOMMENDED SCREW TYPE: M1.8, THREAD-CUTTING,  
MAJOR DIA. 1.80mm - 1.88mm, 5mm MAX. LENGTH
  - RECOMMENDED TORQUE: 576 gf-cm MINIMUM TO 864 gf-cm MAXIMUM.

ADD TORQUE NOTE EC NO: UCP2009-1982 DRWN:DMORGAN 2009/02/17 CHKD:MIBARRA 2009/02/17 APPR:SWILLER 2009/02/18	QUALITY SYMBOLS ▽ - 0 ∇ - 0	GENERAL TOLERANCES (UNLESS SPECIFIED)		SCALE 4:1	DESIGN UNITS METRIC	THIRD ANGLE PROJECTION	REVISE ON CAD ONLY	
		mm	INCH	DIMENSION STYLE MM ONLY		TITLE		
		4 PLACES ± --- ± ---		DRAWN BY MSIMMEL	DATE 2005/12/13	0.8MM HANDYLINK™ 16 CKT CRADLE CONN. ASSY PERPENDICULAR TO PCB MOLEX INCORPORATED		
		3 PLACES ± --- ± ---		CHECKED BY MSIMMEL	DATE 2005/12/13			
		ANGULAR ±1/2°		APPROVED BY JCOMMERCIAL	DATE	MATERIAL NO. 455600160	DOCUMENT NO. SD-45560-001	SHEET NO. 1 OF 27
		DRAFT WHERE APPLICABLE MUST REMAIN WITHIN DIMENSIONS		THIS DRAWING CONTAINS INFORMATION THAT IS PROPRIETARY TO MOLEX INCORPORATED AND SHOULD NOT BE USED WITHOUT WRITTEN PERMISSION				

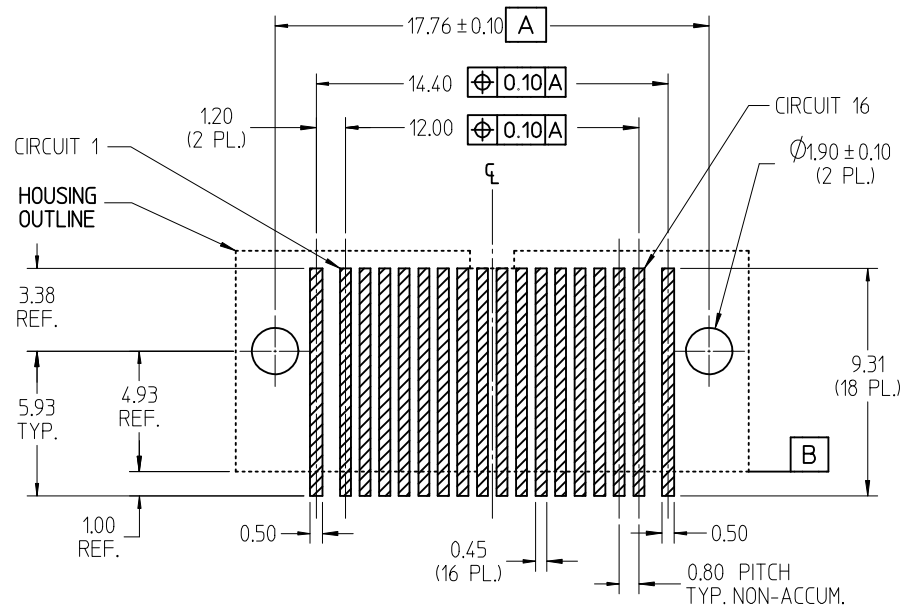

**RECOMMENDED PCB LAYOUT**  
 UNLESS OTHERWISE SPECIFIED  
 TOLERANCES ± 0.05mm  
 RECOMMENDED SOLDER PASTE THICKNESS  
 0.13mm - 0.15mm (.005" - .006")

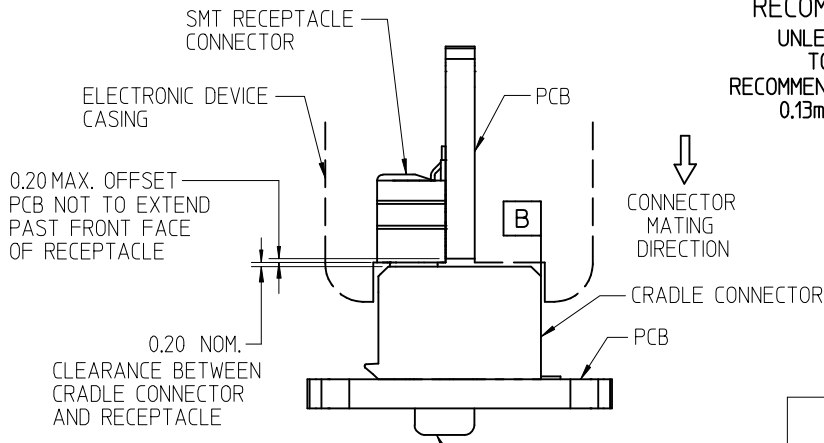
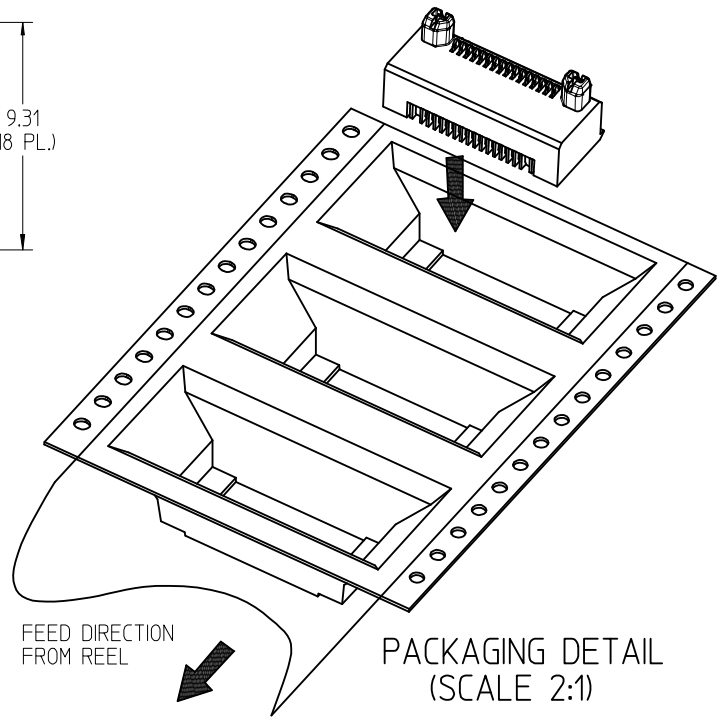

**RECOMMENDATION FOR CONFIGURATION OF MATED CONNECTORS**

**IMPORTANT:** PLEASE REFER TO MOLEX APPLICATION SPECIFICATION AS-44828-001 FOR DETAILED DESIGN LAYOUT AND MATING REQUIREMENTS

SEE SHEET 1 EC NO: UCP2009-1982 DRWN: DMORGAN 2009/02/17 CHKD: MIBARRA 2009/02/17 APPR: SWILLER 2009/02/18	QUALITY SYMBOLS	GENERAL TOLERANCES (UNLESS SPECIFIED)	SCALE 5:1	DESIGN UNITS METRIC	THIRD ANGLE PROJECTION	REVISE ON CAD ONLY
	▼ -0 ∇ -0	mm INCH	DIMENSION STYLE MM ONLY	TITLE	0.8MM HANDYLINK™ 16 CKT CRADLE CONN. ASSY PERPENDICULAR TO PCB	
		4 PLACES ± --- ± --- 3 PLACES ± --- ± --- 2 PLACES ± 0.13 ± --- 1 PLACE ± --- ± ---	DRAWN BY MSIMMEL DATE 2005/12/13 CHECKED BY MSIMMEL DATE 2005/12/13	MOLEX MOLEX INCORPORATED		MATERIAL NO. 455600160 DOCUMENT NO. SD-45560-001 SHEET NO. 2 OF 27
	ANGULAR ±1/2° DRAFT WHERE APPLICABLE MUST REMAIN WITHIN DIMENSIONS	APPROVED BY JCOMERCI	THIS DRAWING CONTAINS INFORMATION THAT IS PROPRIETARY TO MOLEX INCORPORATED AND SHOULD NOT BE USED WITHOUT WRITTEN PERMISSION			