

MATERIAL NUMBER	POSITION NUMBER	DIM. "A"	DIM. "B"	DIM. "C"	QUANTITY OF POLARIZING SLOTS	PANEL THICKNESS ACCOMMODATED
43938-2201	6	20.00 .787	30.90 1.216	41.30 1.626	1	1.30/1.76 .051/.069
43938-2202	8	30.00 1.181	40.90 1.610	51.30 2.020	2	
43938-2203	10	40.00 1.575	50.90 2.004	61.30 2.413	2	
43938-2204	12	50.00 1.968	60.90 2.398	71.30 2.807	2	
43938-2205	14	60.00 2.362	70.90 2.791	81.30 3.201	2	

NOTES:

- MATERIAL: UNFILLED POLYESTER, U.L. 94V-0, COLOR: BLACK
- FINISH: NONE
- PRODUCT SPEC: PS-42815-001
- THIS PART IS DESIGNED TO USE MALE CRIM PTERMINAL #42817
- THIS PART IS DESIGNED TO USE T.P.A. #43980
- THIS PART IS DESIGNED TO MATE WITH RECEPTACLE HOUSING #43914
- SEE SHEET 2 FOR PANEL CUT-OUT DETAILS
- POLARIZING SLOTS TO BE LOCATED BETWEEN CIRCUITS ON EITHER END OF HOUSING OF THE CIRCUIT 1 ROW AS SHOWN.
EXCEPTION: THE 6 CIRCUIT HOUSING WILL HAVE A SINGLE SLOT ON THE CIRCUIT 1 END ONLY
- AN "X" IS ENGRAVED AS SHOWN TO DESIGNATE THAT THE PART ACCOMMODATES A 1.30/1.76 PANEL THICKNESS
- PARTS TO BE PACKAGED: 6~10 CKT PER PK-43938-001, 12~14 CKT PER PK-45286-002

THIS PRODUCT MUST NOT BE USED WITHOUT THE T.P.A.

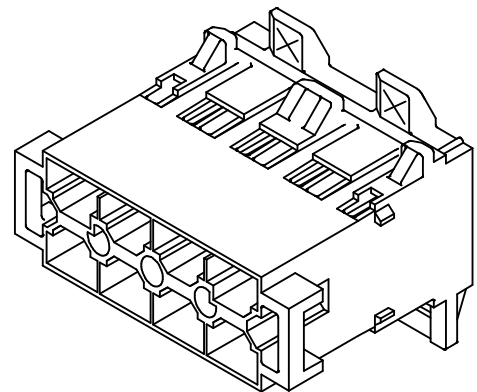
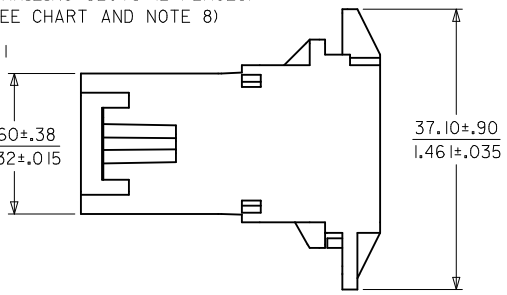
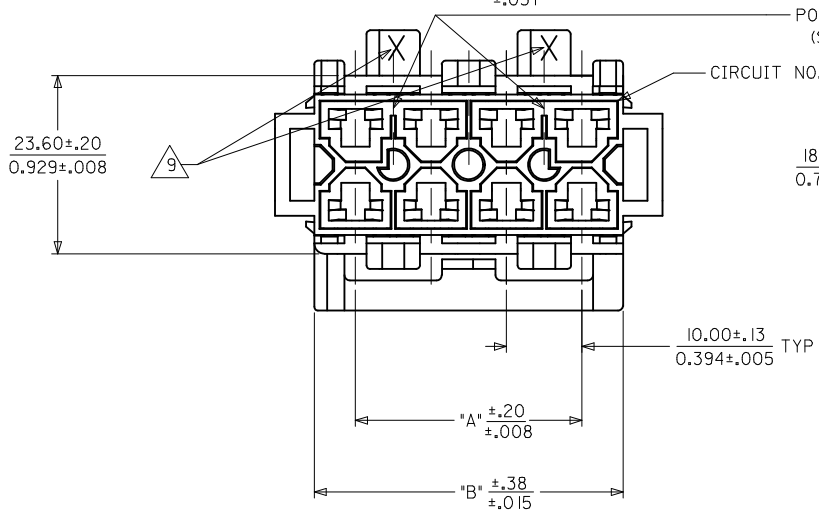
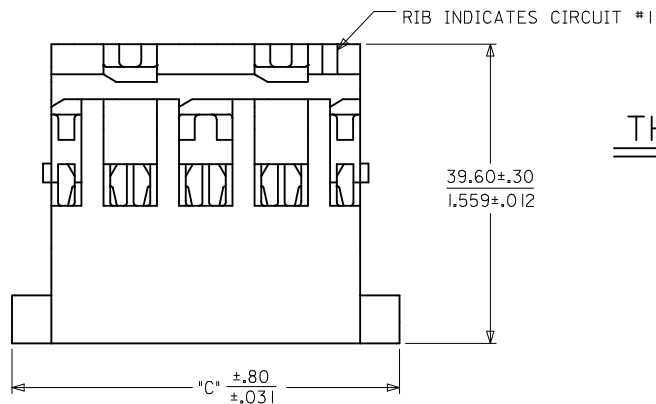

NOTE 10 EC NO: UCP2015-0758 DRWN: JDOX 2014/08/21 CHKD: BANDERSON 2014/08/21 APPR: FSMITH 2014/08/25	QUALITY SYMBOLS ▽=0 ▽=0 ▽=0	GENERAL TOLERANCES (UNLESS SPECIFIED)		DIMENSION STYLE IN/MM		SCALE 2:1	DESIGN UNITS INCH	THIRD ANGLE PROJECTION		
		4 PLACES ± --- ± --- 3 PLACES ± --- ± --- 2 PLACES ± --- ± --- 1 PLACE ± --- ± --- 0 PLACE ± --- ± ---		DRAWN BY JDOX	DATE 2014/08/21	TITLE DUAL ROW PANEL MOUNT PLUG, 6-14 CIRCUIT, MINI-FIT SR. SERIES		SHEET NO. 1 OF 2		
		ANGULAR ±1/2°		CHECKED BY BANDERSON	DATE 2014/08/21	APPROVED BY FSMITH		DATE 2014/08/25	DOCUMENT NO. SD-43938-003	
		DRAFT WHERE APPLICABLE MUST REMAIN WITHIN DIMENSIONS		MATERIAL NO. SEE CHART		SIZE C		THIS DRAWING CONTAINS INFORMATION THAT IS PROPRIETARY TO MOLEX INCORPORATED AND SHOULD NOT BE USED WITHOUT WRITTEN PERMISSION		

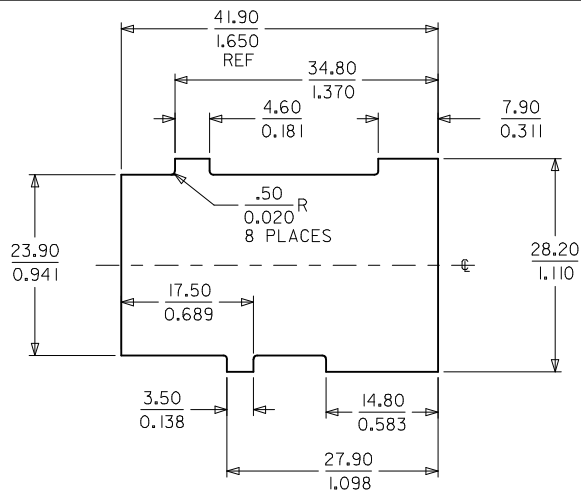

MATERIAL NO.:
43938-2201
6 CIRCUIT

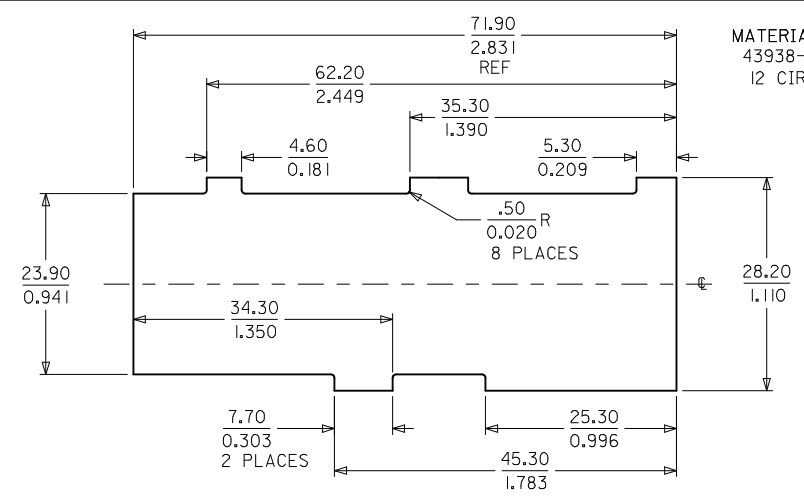

MATERIAL NO.:
43938-2204
12 CIRCUIT

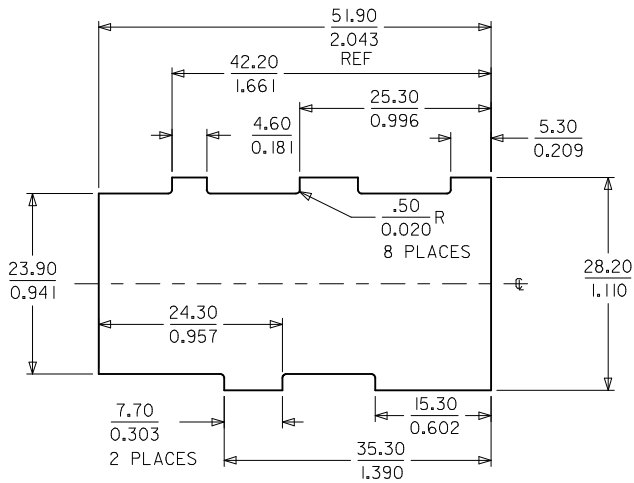

MATERIAL NO.:
43938-1102
43938-2202
8 CIRCUIT

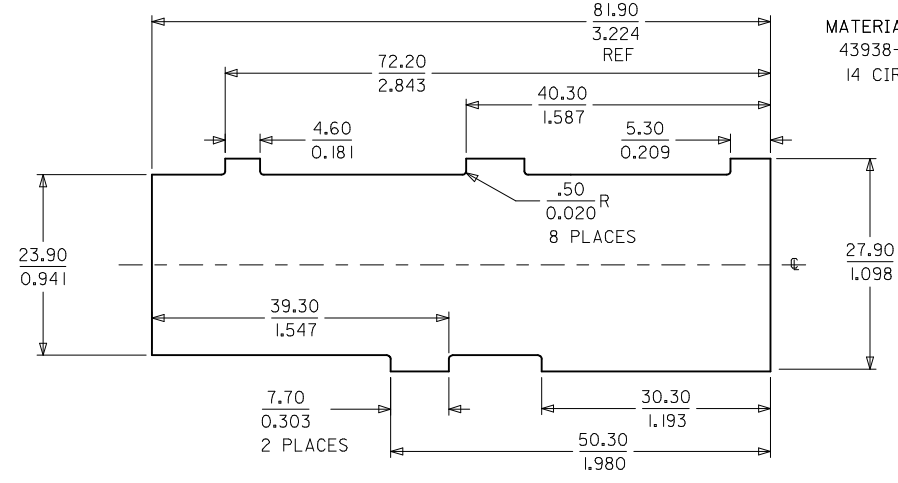

MATERIAL NO.:
43938-2205
14 CIRCUIT

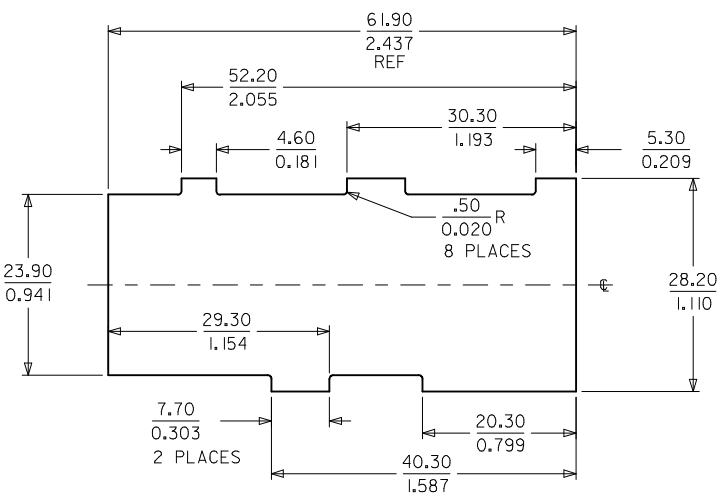

MATERIAL NO.:
43938-2203
10 CIRCUIT

PANEL OPENINGS SHOWN FROM OUTSIDE OF BOX.
SEE CHART FOR PANEL THICKNESS.

SEE SHEET 1 EC NO: UCP2015-0758 DRWN: JDOX CHKD: BANDERSON APPR: FSMITH	2014/08/21 2014/08/21 2014/08/25	DESCRIPTION REV	QUALITY SYMBOLS	GENERAL TOLERANCES (UNLESS SPECIFIED)	DIMENSION STYLE	SCALE	DESIGN UNITS	THIRD ANGLE PROJECTION																																	
			$\nabla = 0$ $\nabla = 0$ $\nabla = 0$	<table border="1"> <tr> <th></th> <th>mm</th> <th>INCH</th> </tr> <tr> <td>4 PLACES</td> <td>± ---</td> <td>± ---</td> </tr> <tr> <td>3 PLACES</td> <td>± ---</td> <td>± ---</td> </tr> <tr> <td>2 PLACES</td> <td>± ---</td> <td>± ---</td> </tr> <tr> <td>1 PLACE</td> <td>± ---</td> <td>± ---</td> </tr> <tr> <td>0 PLACE</td> <td>± ---</td> <td>± ---</td> </tr> </table>		mm	INCH	4 PLACES	± ---	± ---	3 PLACES	± ---	± ---	2 PLACES	± ---	± ---	1 PLACE	± ---	± ---	0 PLACE	± ---	± ---	<table border="1"> <tr> <th>IN/MM</th> <th>DATE</th> </tr> <tr> <td>DRAWN BY</td> <td>JDOX</td> </tr> <tr> <td>DATE</td> <td>2014/08/21</td> </tr> <tr> <td>CHECKED BY</td> <td>BANDERSON</td> </tr> <tr> <td>DATE</td> <td>2014/08/21</td> </tr> <tr> <td>APPROVED BY</td> <td>FSMITH</td> </tr> <tr> <td>DATE</td> <td>2014/08/25</td> </tr> </table>	IN/MM	DATE	DRAWN BY	JDOX	DATE	2014/08/21	CHECKED BY	BANDERSON	DATE	2014/08/21	APPROVED BY	FSMITH	DATE	2014/08/25	TITLE DUAL ROW PANEL MOUNT PLUG, 6-14 CIRCUIT, MINI-FIT SR. SERIES	MATERIAL NO. SEE CHART	DOCUMENT NO. SD-43938-003	SHEET NO. 2 OF 2
				mm	INCH																																				
			4 PLACES	± ---	± ---																																				
3 PLACES	± ---	± ---																																							
2 PLACES	± ---	± ---																																							
1 PLACE	± ---	± ---																																							
0 PLACE	± ---	± ---																																							
IN/MM	DATE																																								
DRAWN BY	JDOX																																								
DATE	2014/08/21																																								
CHECKED BY	BANDERSON																																								
DATE	2014/08/21																																								
APPROVED BY	FSMITH																																								
DATE	2014/08/25																																								
ANGULAR ±1/2°			DRAFT WHERE APPLICABLE MUST REMAIN WITHIN DIMENSIONS			THIS DRAWING CONTAINS INFORMATION THAT IS PROPRIETARY TO MOLEX INCORPORATED AND SHOULD NOT BE USED WITHOUT WRITTEN PERMISSION																																			