

MATERIAL NO. LOOSE PIECE	ENGINEERING NO.	MATERIAL NO. TAPE MOUNTED	ENGINEERING NO.	WIRE RANGE AWG	MM ²	FITS MALE TAB SIZE	L MAX	B ±.01/3	W MAX	D ±.01/3	H ±.01/3	E NOM
190160085	P-1142	190160086	P-1142T	14-12	1.65-4.2	.250x.032	.66/16.8	.190/4.83	.30/7.6	.156/3.96	.103/2.62	.31/7.9
190160099	M-1136-032	190160144	M-1136-032T	26-24	0.1-0.3	.187x.032	.55/14.0	.156/3.96	.24/6.1	.125/3.18	.103/2.62	.25/6.4
190160006	AA-1137-032	190160007	AA-1137-032T	22-18	0.25-1.3	.187x.032	.58/14.7	.200/5.08	.24/6.1	.125/3.18	.103/2.62	.25/6.4
190160040	BB-1138-032	190160041	BB-1138-032T	16-14	1.0-2.6	.187x.032	.58/14.7	.200/5.08	.24/6.1	.125/3.18	.103/2.62	.25/6.4
190160082	P-1139-032	190160083	P-1139-032T	14-12	1.65-4.2	.187x.032	.58/14.7	.200/5.08	.24/6.1	.125/3.18	.103/2.62	.25/6.4
190160098	M-1136	190160100	M-1136T	26-24	0.1-0.3	.187x.020	.55/14.0	.156/3.96	.24/6.1	.125/3.18	.086/2.18	.25/6.4
190160005	AA-1137	190160008	AA-1137T	22-18	0.25-1.3	.187x.020	.58/14.7	.200/5.08	.24/6.1	.125/3.18	.086/2.18	.25/6.4
190160039	BB-1138	190160042	BB-1138T	16-14	1.0-2.6	.187x.020	.58/14.7	.200/5.08	.24/6.1	.125/3.18	.086/2.18	.25/6.4
190160081	P-1139	190160084	P-1139T	14-12	1.65-4.2	.187x.020	.58/14.7	.200/5.08	.24/6.1	.125/3.18	.086/2.18	.25/6.4

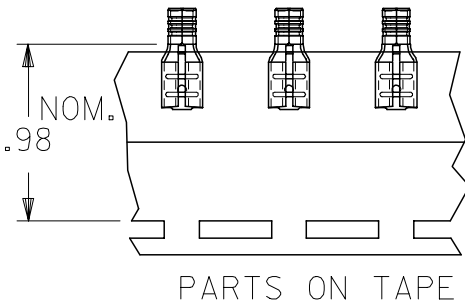

WIRE RANGE WIRE STOP

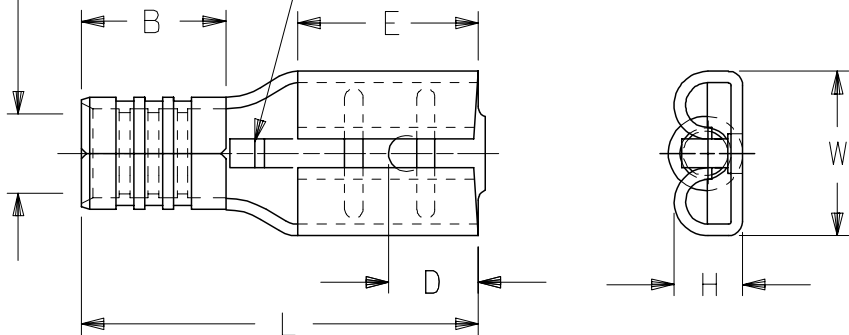

NOTES:

1. MATERIAL: BRASS (.016/.41 THICK)
2. PLATING: ELECTROPLATE TIN
3. ALL DIMENSIONS IN INCHES/MM
WIRE SIZE: SEE CHART

ADDED MATERIAL NO FC NO: ETC2006-0197 DRAWN BY: DEH CHKD: JLOMASTRO APPR: RDEROSS	QUALITY SYMBOLS =0 =0	GENERAL TOLERANCES (UNLESS SPECIFIED)		DIMENSION STYLE IN/MM		SCALE 4:1	DESIGN UNITS INCH	THIRD ANGLE PROJECTION
		mm	INCH	DRAWN BY RCM	DATE 90/11/28	TITLE KRIMPTITE QUICK DISCONNECT		
REV	DESCRIPTION	4 PLACES	± .005	± .005	CHECKED BY RCM	DATE 90/11/28	MOLEX INCORPORATED	
		3 PLACES	± .01	± .01	APPROVED BY RDEROSS	DATE 90/11/28	DOCUMENT NO. SD-19016-004	
		2 PLACES	± 0.25	± .01	MATERIAL NO. SEE CHART		SHEET NO. 1 OF 1	
		1 PLACE	± 0.25	± .01	SIZE C		THIS DRAWING CONTAINS INFORMATION THAT IS PROPRIETARY TO MOLEX INCORPORATED AND SHOULD NOT BE USED WITHOUT WRITTEN PERMISSION	
		ANGULAR ±1/2°		DRAFT WHERE APPLICABLE MUST REMAIN WITHIN DIMENSIONS				