

MATERIAL NO.	ENGINEERING NO.	φA MWID	φB ID	TERMINAL MATERIAL	TERMINAL FINISH
191640019	SAMCT-2	.185/4.70 (D)	.054/1.37 (D)	BRASS, .031/0.79 THK REF	ZINC CHROMATE
191640084	SMCT-2	.195/4.95 (D)	.082/2.08	BRASS, .031/0.79 THK REF	ZINC CHROMATE
191640078	SCMCT-2	.275/6.99 (D)	.144/3.65 (D)	BRASS, .031/0.79 THK REF	ZINC CHROMATE

(D)

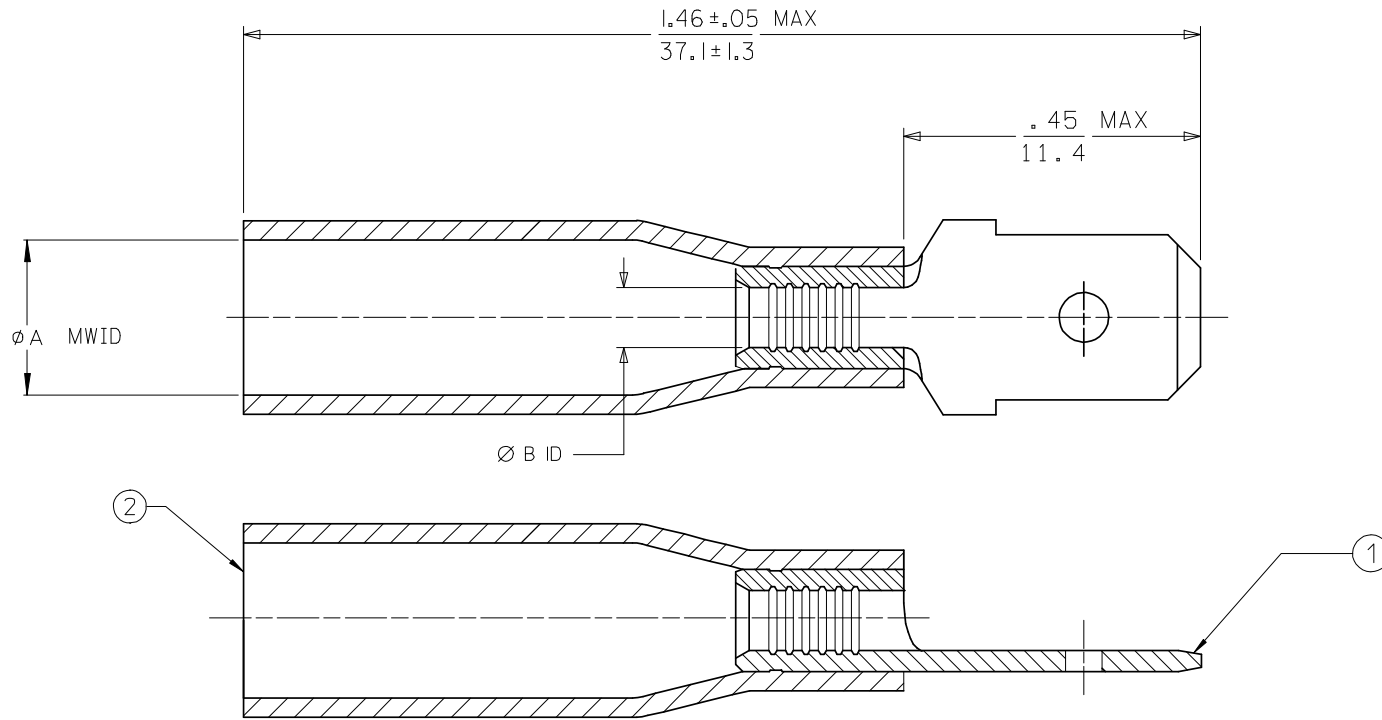

NOTES:

(D)

- TAB DIMENSIONS PER UL310 SPECIFICATIONS.
- TAB MATERIAL: SEE CHART
FINISH: SEE CHART
- INSULATION MATERIAL: HEAT SHRINKABLE TUBING WITH HOTMELT ADHESIVE INNER LINER,
- MWID = MAXIMUM WIRE INSULATION DIAMETER.
- PART IS ROHS COMPLAINT.

SALES DRAWING

CHANGED MATL & FINISH EC NO: ETC2007-0081 DRWN:EHILE 2008/01/28 CHKD:MACNEIL 2008/01/28 APPR:MACNEIL 2008/02/13	REV	DESCRIPTION
	D	

QUALITY SYMBOLS
▽=0
▽=0

GENERAL TOLERANCES (UNLESS SPECIFIED)	
	mm
4 PLACES	± ---
3 PLACES	± --- ± .005
2 PLACES	± 0.13 ± .010
1 PLACE	± 0.25 ± ---
ANGULAR ± --- °	
DRAFT WHERE APPLICABLE MUST REMAIN WITHIN DIMENSIONS	

DIMENSION STYLE	
IN/MM	
DRAWN BY	DATE
JLOMASTRO	05/10/13
CHECKED BY	DATE
RDEROSS	05/10/13
APPROVED BY	DATE
RDEROSS	05/10/13
MATERIAL NO.	DOCUMENT NO.
SEE CHART	SD-19164-049
SIZE B	THIS DRAWING CONTAINS INFORMATION THAT IS PROPRIETARY TO MOLEX INCORPORATED AND SHOULD NOT BE USED WITHOUT WRITTEN PERMISSION

SCALE ---	DESIGN UNITS INCH	THIRD ANGLE PROJECTION
TITLE		
PERMA-SEAL QD MALE TERMINAL LONG BARREL		
MOLEX MOLEX INCORPORATED		
MATERIAL NO.	DOCUMENT NO.	SHEET NO.
SEE CHART	SD-19164-049	1 OF 1