

4 DIGIT DATE CODE ON THIS SURFACE, MUST BE SOLVENT RESISTANT

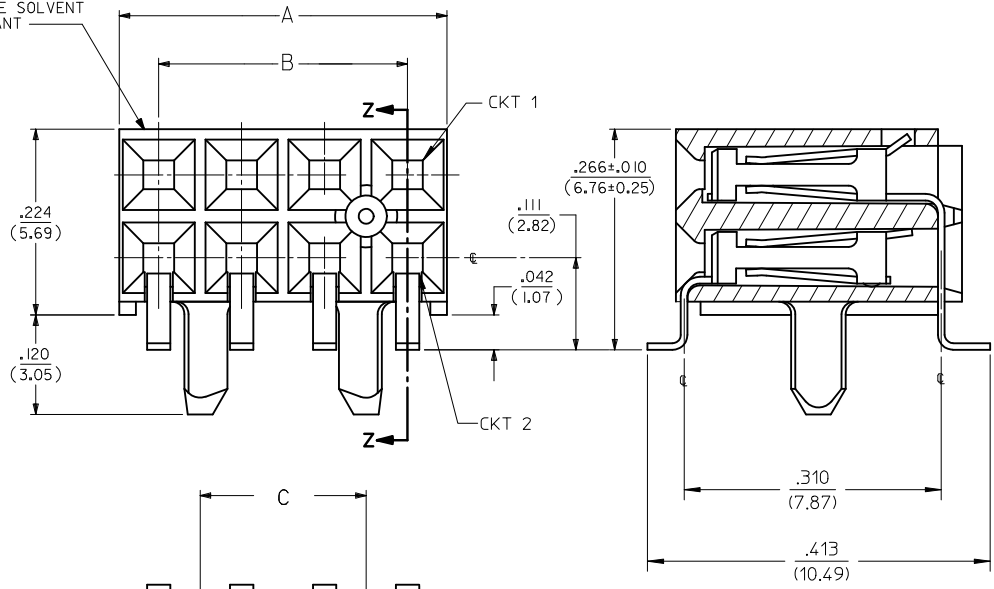

SECTION Z-Z

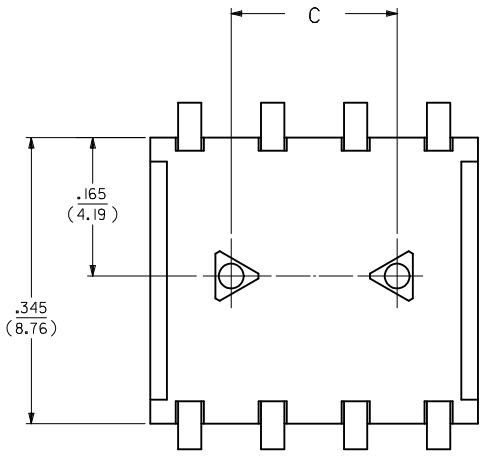

OPTION A ASSEMBLY
(ASSEMBLY WITH PEG AND WITHOUT LOWER ROW PINSTOP)

NOTES:

- 1.) MATERIALS:
HOUSING - LCP, 94V-0, BLACK
TERMINAL - PHOS. BRONZE ALLOY
- 2.) 8 CKT SHOWN FOR ILLUSTRATION PURPOSES. SEE CHART ON SHEET 7 FOR OTHER SIZES.
- 3.) SCRATCHES AND BURNISHING ALLOWED ON TERMINAL TAILS PROVIDING BASE METAL IS NOT EXPOSED, EXCEPT AT TRIMMED END.
- 4.) RECOMMENDED MATING PIN LENGTHS:
LOWER ROW - .200" MIN./ .285" MAX.
UPPER ROW - .200" MIN.
- 5.) REFER TO PS-71973-9999 FOR PERFORMANCE DATA.

PLATING:

- 15 GOLD 15 MICROINCH MINIMUM SELECTIVE GOLD IN THE CONTACT AREA; 75 MICROINCH MINIMUM SELECTIVE TIN IN THE PC TAIL AREA OVER 50 MICROINCH MINIMUM NICKEL OVERALL.
- 30 GOLD 30 MICROINCH MINIMUM SELECTIVE GOLD IN THE CONTACT AREA; 75 MICROINCH MINIMUM SELECTIVE TIN IN THE PC TAIL AREA OVER 50 MICROINCH MINIMUM NICKEL OVERALL.
- 50 GOLD 50 MICROINCH MINIMUM SELECTIVE GOLD IN THE CONTACT AREA; 75 MICROINCH MINIMUM SELECTIVE TIN IN THE PC TAIL AREA OVER 50 MICROINCH MINIMUM NICKEL OVERALL.

*THE PRIMARY SHIPPING CARTON WILL BE LABELED "COMPLIANT TO RoHS DIRECTIVE 2002/95/EC AND ELV ANNEX II OF DIRECTIVE 2000/53/EC". CARTONS WITHOUT THIS LABEL MAY CONTAIN PRODUCT WITH LEAD.

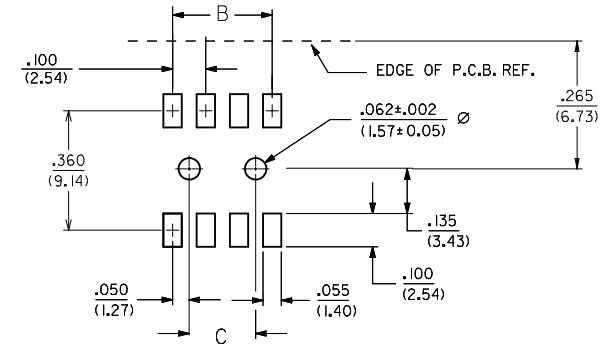

RECOMMENDED P.C.B. LAYOUT

REVISED AS PER GCN#10501265

EC NO: S2012-0693 DRWN:ATSEE CHKD:SKANG APPR:MLONG 2012/03/09 2012/03/09 2012/04/25	DESCRIPTION H3	QUALITY SYMBOLS	GENERAL TOLERANCES (UNLESS SPECIFIED)	DIMENSION STYLE	SCALE	DESIGN UNITS	THIRD ANGLE PROJECTION
		▽=0 Ⓢ=0	mm INCH 4 PLACES ± --- ± --- 3 PLACES ± --- ± --- 2 PLACES ± --- ± .01 1 PLACE ± 0.25 ± --- ANGULAR ± 1/2°	IN/MM DRAWN BY: DJB DATE: 1995/03/15 CHECKED BY: DATE: 1995/03/15 APPROVED BY: MLONG DATE: 2012/04/25	NTS TITLE: SMT RECEPTACLE RIGHT ANGLE, DUAL ROW WITH AND WITHOUT PEG	MOLEX MOLEX INCORPORATED	SHEET NO. 1 OF 2
		DRAFT WHERE APPLICABLE MUST REMAIN WITHIN DIMENSIONS	MATERIAL NO. SEE TABLE	DOCUMENT NO. SD-71979-001	THIS DRAWING CONTAINS INFORMATION THAT IS PROPRIETARY TO MOLEX INCORPORATED AND SHOULD NOT BE USED WITHOUT WRITTEN PERMISSION		
		SIZE A3					

10 9 8 7 6 5 4 3 2 1

7 979 0234 7 979 0334 7 979 0434
 7 979 0235 7 979 0335 7 979 0435
 7 979 0236 7 979 0336 7 979 0436

79 03 6 7 979 04 6
 7 979 02 7 7 979 03 7 7 979 04 7
 7 979 02 8 7 979 03 8 7 979 04 8
 7 979 02 9 7 979 03 9 7 979 04 9
 7 979 0220 7 979 0320 7 979 0420
 7 979 022 7 979 032 7 979 042
 7 979 0222 7 979 0322 7 979 0422
 7 979 0223 7 979 0323 7 979 0423
 7 979 0224 7 979 0324 7 979 0424
 7 979 0225 7 979 0325 7 979 0425
 7 979 0226 7 979 0326 7 979 0426
 7 979 0227 7 979 0327 7 979 0427
 7 979 0228 7 979 0328 7 979 0428
 7 979 0229 7 979 0329 7 979 0429
 7 979 0230 7 979 0330 7 979 0430
 7 979 023 7 979 033 7 979 043
 7 979 0232 7 979 0332 7 979 0432
 7 979 0233 7 979 0333 7 979 0433

REVISED AS PER GCN# 10501265 EC NO: S2012-0693 2012/03/09 DRWINATSEE CHYKDSKANG 2012/03/09 APPR:MLONG 2012/04/25 H3	QUALITY SYMBOLS	GENERAL TOLERANCES (UNLESS SPECIFIED)		DIMENSION STYLE IN/MM		SCALE NTS	DESIGN UNITS INCH	THIRD ANGLE PROJECTION		
	= 0 = 0	4 PLACES ± --- ± --- 3 PLACES ± --- ± --- 2 PLACES ± --- ± .01 1 PLACE ± 0.25 ± --- ANGULAR ± 1/2°	DRAWN BY DJB CHECKED BY DJB APPROVED BY MLONG	DATE 1995/03/15 DATE 1995/03/15 DATE 2012/04/25	TITLE SMT RECEPTACLE RIGHT ANGLE, DUAL ROW WITH AND WITHOUT PEG		molex MOLEX INCORPORATED		SHEET NO. 2 OF 2	
	DRAFT WHERE APPLICABLE MUST REMAIN WITHIN DIMENSIONS	SEE TABLE		DOCUMENT NO. SD-71979-001						
		THIS DRAWING CONTAINS INFORMATION THAT IS PROPRIETARY TO MOLEX INCORPORATED AND SHOULD NOT BE USED WITHOUT WRITTEN PERMISSION								

9 8 7 6 5 4 3 2 1