

RECOMMENDED P.C. BOARD HOLE PATTERN FOR STRAIGHT PINS

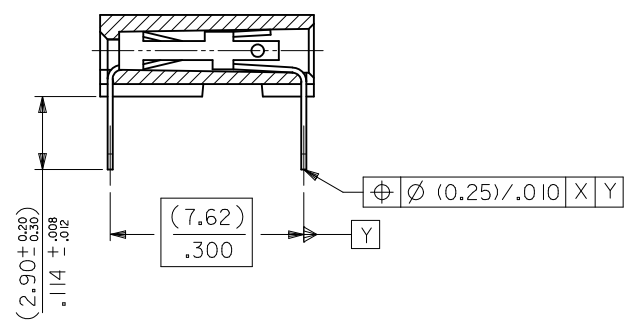

SECTION C-C SHOWING STRAIGHT PINS

NOTES

- 1) CONTACT-PLATED PHOSPHOR BRONZE. (SEE SHEET 2)
- 2) HOUSING
POLYESTER (PBT), 15% GLASS FILL, UL94-V0.
COLOR: BLACK.
ALSO
POLYAMIDE (PA4/6), 30% GLASS FILL, UL94-V0.
COLOR: NATURAL.
- 3) FOR (0.635)/.025 SQ. MALE PINS THE LENGTH MUST BE (5.65)/.222 MIN & (7.00)/.276 MAX. TO ENSURE GOOD CONNECTION WITH CONTACT.
- 4) PRODUCT SPECIFICATION: PS-99020-0001
- 5) PCB THICKNESS 1.6MM

UPDATE TOL. SYMMETRY EC NO: S2010-0968 DRWN:SKANG 2010/05/26 CHKD:ATSEE 2010/06/04 APPR:MLONG 2010/06/05	REV AK	DESCRIPTION	QUALITY SYMBOLS	GENERAL TOLERANCES (UNLESS SPECIFIED)		DIMENSION STYLE		SCALE	DESIGN UNITS	THIRD ANGLE PROJECTION	
			$F_{\Delta} = 0$ $F_{\nabla} = 0$ $F_{\square} = 0$	mm	INCH	MM ONLY	NTS	METRIC			
			4 PLACES	± ---	± ---	DRAWN BY	DATE	TITLE			
			3 PLACES	± ---	± ---	CHECKED BY	DATE	C-GRID III SINGLE ROW HORIZONTAL P.C BOARD CONN.			
			2 PLACES	± 0.15	± ---	APPROVED BY	DATE	MOLEX INCORPORATED			
			1 PLACE	± ---	± ---	J. DENNEHY	2010/06/04	DOCUMENT NO. SDA-90148			
			ANGULAR ± 2 °		MATERIAL NO.		DOCUMENT NO.		SHEET NO.		
			DRAFT WHERE APPLICABLE MUST REMAIN WITHIN DIMENSIONS		SEE TABLE		SDA-90148		1 OF 3		
					SIZE A3		THIS DRAWING CONTAINS INFORMATION THAT IS PROPRIETARY TO MOLEX INCORPORATED AND SHOULD NOT BE USED WITHOUT WRITTEN PERMISSION				

PART NO's - STRAIGHT PINS		PART NO.	NO OF CKTS.	DIM. A		DIM. B ^(+0.30) _{-0.02}		NO. PER TUBE
STANDARD	CUSTOMER SPECIFIC							
90148-1X02		90148-4X02	2	(2.54)	.100	(5.08)	.200	105
↑	↑ 03	↑	↑ 03	(5.08)	.200	(7.62)	.300	72
	04		04	(7.62)	.300	(10.16)	.400	52
	05		05	(10.16)	.400	(12.70)	.500	44
	06	90148-9X06	06	(12.70)	.500	(15.24)	.600	36
	07		07	(15.24)	.600	(17.78)	.700	30
	08		08	(17.78)	.700	(20.32)	.800	26
	09		09	(20.32)	.800	(22.86)	.900	24
	10		10	(22.86)	.900	(25.40)	1.000	22
	11		11	(25.40)	1.000	(27.94)	1.100	18
	12		12	(27.94)	1.100	(30.48)	1.200	18
	13		13					16
	14		14	(33.02)	1.300	(35.56)	1.400	14
	15		15	(35.56)	1.400	(38.10)	1.500	14
	16		16					13
	17		17					12
	18		18	(43.18)	1.700	(45.72)	1.800	12
	19		19	(45.72)	1.800	(48.26)	1.900	12
	20		20	(48.26)	1.900	(50.80)	2.000	11
	21		21					10
	22		22					10
	23		23					10
	24		24					9
	25		25	(60.96)	2.400	(63.50)	2.500	8
	26		26	(63.50)	2.500	(66.04)	2.600	8
	27		27					8
	28		28					7
	29		29					7
	30		30	(73.66)	2.900	(76.20)	3.000	7
	↓ 31		↓ 31					7
90148-1X32		90148-4X32	32	(78.74)	3.100	(81.28)	3.200	6

PLATING VERSION A

PRE-PLATED HOT DIP TIN

1.0 TO 2.5 microns (.00004" TO .00010").

PLATING VERSION E

1.27 TO 1.78 microns (.00005" TO .00007") NICKEL

OVERALL, 0.38 TO 0.64 microns (.000015" TO .000025")

GOLD ON CONTACT AREA (OVER NICKEL).

3 TO 5 microns (.00012" TO .00020") TIN

ON SOLDER TAILS (OVER NICKEL).

PLATING VERSION F.

1.27 TO 1.78 microns (.00005" TO .00007") NICKEL

OVERALL, 0.76 TO 1.0 microns (.00003" TO .00004")

GOLD ON CONTACT AREA (OVER NICKEL).

3 TO 5 microns (.00012" TO .00020") TIN

ON SOLDER TAILS (OVER NICKEL).

90148-XXYY

INDICATES NO. OF CIRCUITS

PLATING CODE

1 = VERSION A

2 = VERSION E

3 = VERSION F

1 = STRAIGHT PINS POLYESTER

9 = STRAIGHT PINS POLYESTER

4 = STRAIGHT PINS NYLON 46

UPDATE TOL. SYMMETRY EC NO: S2010-0968 DRWN:SKANG 2010/05/26 CHKD:ATSEE 2010/06/04 APPR:MLONG 2010/06/05	QUALITY SYMBOLS	GENERAL TOLERANCES (UNLESS SPECIFIED)	DIMENSION STYLE	SCALE	DESIGN UNITS	THIRD ANGLE PROJECTION	
	▽ _A =0 ▽ _C =0 ▽ _P =0	mm INCH	MM ONLY	NTS	METRIC		
		4 PLACES ± --- ± --- 3 PLACES ± --- ± --- 2 PLACES ± 0.15 ± --- 1 PLACE ± --- ± ---	DRAWN BY DATE DB 1987/07/14	TITLE	C-GRID III SINGLE ROW HORIZONTAL P.C BOARD CONN.		
		ANGULAR ± 2 °	CHECKED BY DATE D.MORIARTY 2005/03/02	APPROVED BY DATE J.DENNEHY 2010/06/04	MOLEX INCORPORATED		
AK	DESCRIPTION	DRAFT WHERE APPLICABLE MUST REMAIN WITHIN DIMENSIONS	SIZE	MATERIAL NO.	DOCUMENT NO.	SHEET NO.	
			A3	SEE TABLE	SDA-90148	2 OF 3	
			THIS DRAWING CONTAINS INFORMATION THAT IS PROPRIETARY TO MOLEX INCORPORATED AND SHOULD NOT BE USED WITHOUT WRITTEN PERMISSION				

PART NO.	POLARISED CCT NO.	NO. OF CKTS.	DIM. A	DIM. B (± 0.30) (± 0.012)	NO. PER TUBE
90148-3X01	2	3	(5.08) .200	(7.62) .300	72

NON-STANDARD PRODUCTS

90148-XXYY
 OPTION NUMBER (NOT RELATING TO CCT SIZE OR OTHERWISE)
 PLATING CODE (SEE SHEET 2)
 3 = STRAIGHT PINS POLYESTER, POLARISED

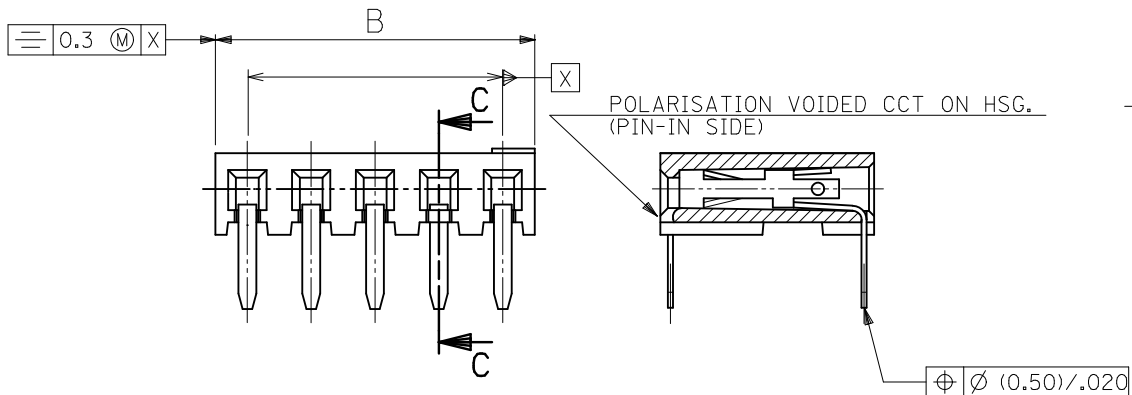

SECTION C-C SHOWING POLARISED CCT

POLARISATION VOIDED
 CCT ON P.C.B.
 (PIN-IN SIDE)

PIN INSERTION TO HOUSING FROM THIS SIDE

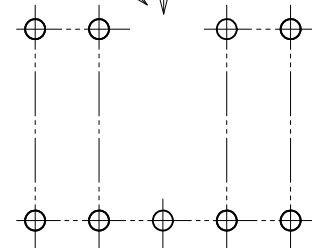

RECOMMENDED P.C. BOARD HOLE PATTERN FOR STRAIGHT PINS WITH POLARISATION

NOTES

- 1) SEE SHEET 1 FOR ALL UNSPECIFIED DIMENSIONS AND NOTES.
- 2) PARTS NOT STACKABLE.

UPDATE TOL. SYMMETRY EC NO: SZ010-0968 DRWN: SKANG CHKD: ATSEE APPR: MLONG	2010/05/26 2010/06/04 2010/06/05	QUALITY SYMBOLS F=0 F=0 F=0	GENERAL TOLERANCES (UNLESS SPECIFIED)		DIMENSION STYLE MM ONLY		SCALE NTS	DESIGN UNITS METRIC	THIRD ANGLE PROJECTION	
			4 PLACES ± --- ± --- 3 PLACES ± --- ± --- 2 PLACES ± 0.15 ± --- 1 PLACE ± --- ± ---	DRAWN BY DB	DATE 1987/07/14	TITLE C-GRID III SINGLE ROW HORIZONTAL P.C BOARD CONN.				
			ANGULAR ± 2 °	CHECKED BY D. MORIARTY	DATE 2005/03/02	MOLEX INCORPORATED				
			DRAFT WHERE APPLICABLE MUST REMAIN WITHIN DIMENSIONS	APPROVED BY J. DENNEHY	DATE 2010/06/04	MATERIAL NO. SEE TABLE	DOCUMENT NO. SDA-90148	SHEET NO. 3 OF 3		

PART NO's - STRAIGHT PINS		PART NO.	NO OF CKTS.	DIM. A	DIM. B $(\pm \frac{0.30}{.32})$	NO. PER TUBE
STANDARD	CUSTOMER SPECIFIC					
90148-1X02		90148-4X02	2	(2.54) .100	(5.08) .200	105
↑ 03	↑	↑ 03	3	(5.08) .200	(7.62) .300	72
04	↓	04	4	(7.62) .300	(10.16) .400	52
05		05	5	(10.16) .400	(12.70) .500	44
06	90148-9X06	06	6	(12.70) .500	(15.24) .600	36
07		07	7	(15.24) .600	(17.78) .700	30
08		08	8	(17.78) .700	(20.32) .800	26
09		09	9	(20.32) .800	(22.86) .900	24
10		10	10	(22.86) .900	(25.40) 1.000	22
11		11	11	(25.40) 1.000	(27.94) 1.100	18
12		12	12	(27.94) 1.100	(30.48) 1.200	18
13		13	13			16
14		14	14	(33.02) 1.300	(35.56) 1.400	14
15		15	15	(35.56) 1.400	(38.10) 1.500	14
16		16	16			13
17		17	17			12
18		18	18	(43.18) 1.700	(45.72) 1.800	12
19		19	19	(45.72) 1.800	(48.26) 1.900	12
20		20	20	(48.26) 1.900	(50.80) 2.000	11
21		21	21			10
22		22	22			10
23		23	23			10
24		24	24			9
25		25	25	(60.96) 2.400	(63.50) 2.500	8
26		26	26	(63.50) 2.500	(66.04) 2.600	8
27		27	27			8
28		28	28			7
29		29	29			7
30		30	30	(73.66) 2.900	(76.20) 3.000	7
↓ 31	↓	↓ 31	31			7
90148-1X32		90148-4X32	32	(78.74) 3.100	(81.28) 3.200	6

PLATING VERSION A

PRE-PLATED HOT DIP TIN
1.0 TO 2.5 microns (.00004" TO .00010").

PLATING VERSION E

1.27 TO 1.78 microns (.00005" TO .00007") NICKEL
OVERALL, 0.38 TO 0.64 microns (.000015" TO .000025")
GOLD ON CONTACT AREA (OVER NICKEL).
3 TO 5 microns (.00012" TO .00020") TIN
ON SOLDER TAILS (OVER NICKEL).

PLATING VERSION F.

1.27 TO 1.78 microns (.00005" TO .00007") NICKEL
OVERALL, 0.76 TO 1.0 microns (.00003" TO .00004")
GOLD ON CONTACT AREA (OVER NICKEL).
3 TO 5 microns (.00012" TO .00020") TIN
ON SOLDER TAILS (OVER NICKEL).

90148-XXXX

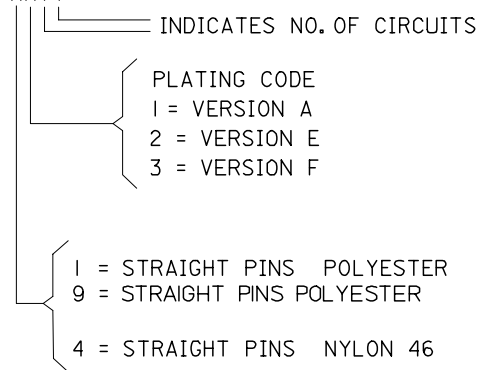

ADD NEW P/N EC NO: E2007-0823 DRWN: DBYRNES CHKD: 2007/03/29 APPR: EOMAHONY 2007/04/04	QUALITY SYMBOLS	GENERAL TOLERANCES (UNLESS SPECIFIED)	DIMENSION STYLE MM ONLY	SCALE ---	DESIGN UNITS METRIC	THIRD ANGLE PROJECTION	
	▽=0 ▽C=0	4 PLACES ±--- ±--- 3 PLACES ±--- ±--- 2 PLACES ±--- ±--- 1 PLACE ±--- ±--- ANGULAR ±---°	mm INCH	DRAWN BY DB	DATE 1987/07/14	TITLE C-GRID III SINGLE ROW HORIZONTAL P.C. BOARD CONNECTOR	
		DRAFT WHERE APPLICABLE MUST REMAIN WITHIN DIMENSIONS	APPROVED BY J. DENNEHY	DATE	MOLEX	MOLEX INCORPORATED	
	AJ		SEE CHART	MATERIAL NO.	DOCUMENT NO. SDA-90148	SHEET NO. 2 OF 3	