

NOTES:

1. MATERIALS:
 HOUSING: GLASS-FILLED LIQUID CRYSTAL POLYMER (LCP), UL94 V-0, COLOR: BLACK
 TAIL ALIGNER: GLASS-FILLED LIQUID CRYSTAL POLYMER (LCP),
 TERMINAL: PHOSPHOR BRONZE
 BRACKET: BRASS
 SHELL: STEEL
 INSERT: BRASS
2. FINISHES:
 TERMINAL: 0.05-0.25 MICROMETERS GOLD FLASH IN CRITICAL AREA
 OVER 0.75 MICROMETERS MINIMUM PALLADIUM NICKEL IN
 CRITICAL AREA. 1.87 MICROMETERS MINIMUM TIN IN
 SOLDER TAIL AREA OVER A NICKEL UNDERPLATE.
 SHIELD: 3.8 MICROMETERS MINIMUM BRIGHT TIN OVER NICKEL.
 INSERT: 2.54 MICROMETERS MINIMUM NICKEL.
3. PART CONFORMS TO MOLEX PRODUCT SPECIFICATION PS-71425-9999.
4. PACKAGED PER PK-71430-0101.
5. APPLICABLE STANDARDS: EIA-3652 AND SFF-8441.
6. DATE CODE: YR/WK PER EIA-476-A.
7. PRODUCT COMPLIES WITH COSMETIC SPECIFICATION PS-45499-002.
 SEE SIDE VIEW FOR SURFACE CLASSIFICATIONS.
8. TORQUE TO INSTALL SCREWLOCKS INTO THREADED INSERTS:
 0.34 Nm MAXIMUM.

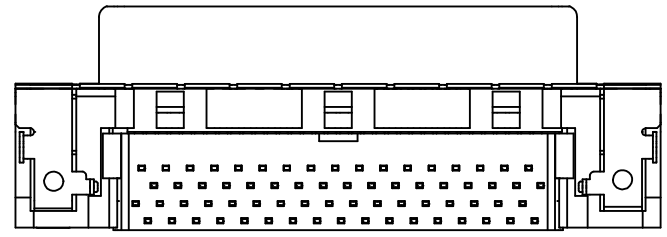
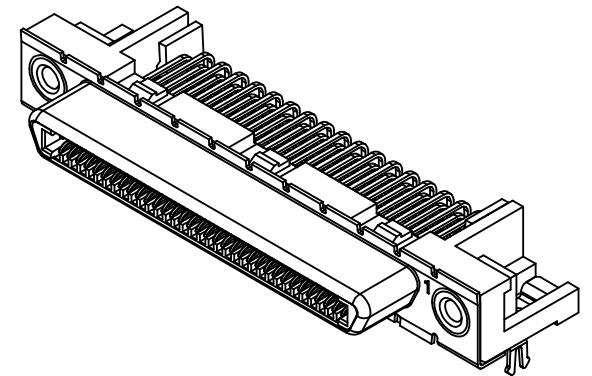
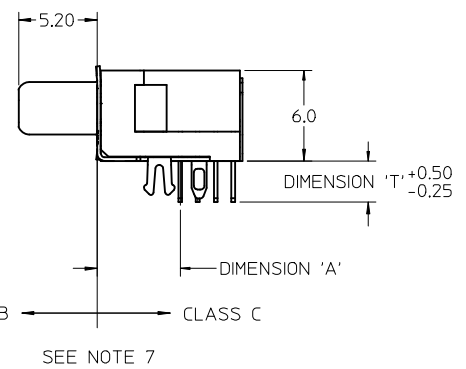
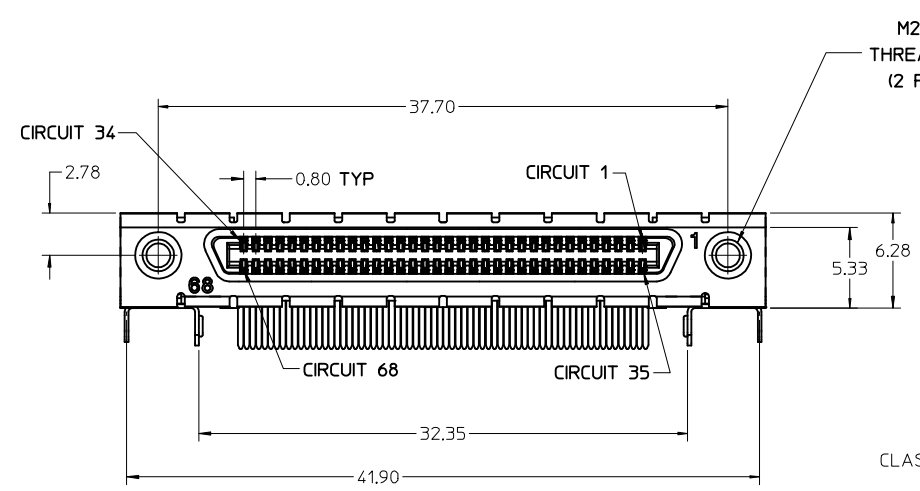
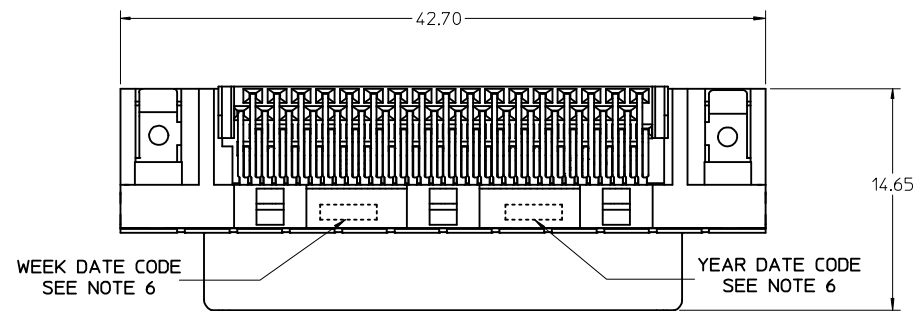

FIX TAIL TOLERANCE EC NO: UCP2012-3896 DRW: BARKER 2012/05/29 CHKD: MWLF APPR: SMILLER 2012/08/31	QUALITY SYMBOLS ∇=0 ∇=0 ∇=0	GENERAL TOLERANCES (UNLESS SPECIFIED)		DIMENSION STYLE MM ONLY	SCALE 4:1	DESIGN UNITS METRIC	THIRD ANGLE PROJECTION	
		4 PLACES ± --- ± ---	DRAWN BY KSTILES	DATE 11/14/2002	TITLE VHDCl RIGHT ANGLE ASSEMBLY			
		3 PLACES ± --- ± ---	CHECKED BY KSTILES	DATE 11/15/2002	molex			
		2 PLACES ± 0.13 ± ---	APPROVED BY MBNAK I S	DATE 11/22/2002	MATERIAL NO. SEE SHEET 2	DOCUMENT NO. SD-71430-015	SHEET NO. 1 OF 3	
1 PLACE ± 0.25 ± ---	ANGULAR ±1/2°		THIS DRAWING CONTAINS INFORMATION THAT IS PROPRIETARY TO MOLEX INCORPORATED AND SHOULD NOT BE USED WITHOUT WRITTEN PERMISSION					
0 PLACE ± ±	DRAFT WHERE APPLICABLE MUST REMAIN WITHIN DIMENSIONS							

PCB THICKNESS	PART NUMBER	TAIL LENGTH *T* (SEE FIGURE FOR TOLERANCE)	ENHANCED GROUND TABS	SCREWLOCKS	TAIL LOC. *A*	HOLE LOCATION *B*
1.60	71430-0101	2.08	NO	NONE	5.5	6.50 MAXIMUM
1.60	71430-0007	2.08	NO	LOOSE IN BAGS		
1.60	71430-0005	2.08	YES	NONE		
1.60	71430-0008	2.08	YES	LOOSE IN BAGS		
2.36	71430-0268	2.71	NO	NONE		
2.36	71430-0006	2.71	NO	INSTALLED		
2.36	71430-0004	2.71	YES	NONE		
2.36	71430-0009	2.71	YES	INSTALLED		
2.36	71430-0016	2.71	NO	LOOSE IN BAGS		
2.36	71430-0019	2.71	YES	LOOSE IN BAGS		
2.36	71430-0012	2.71	YES	NONE	5.3	6.30 MAXIMUM
1.60	71430-0013	2.08	YES	NONE		

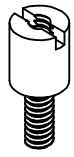
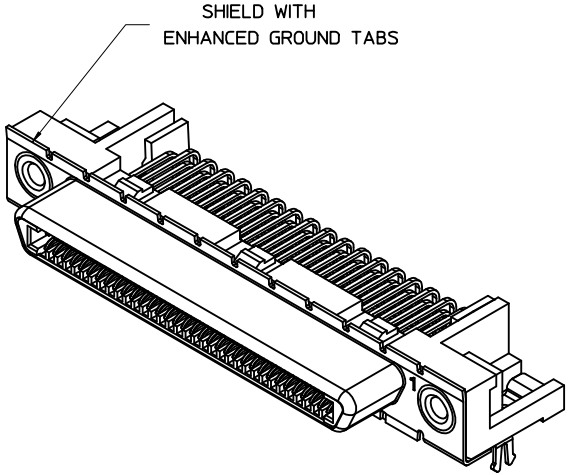
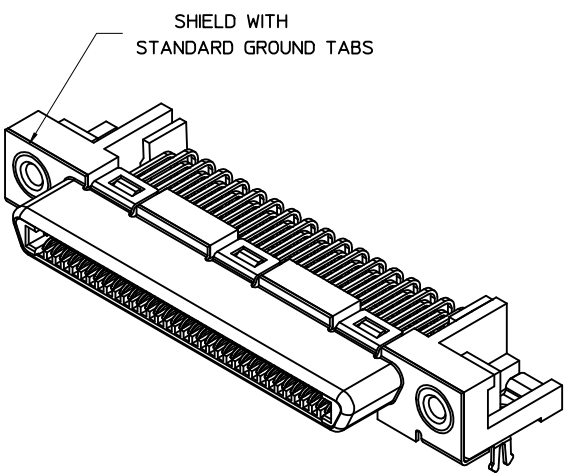

OPTIONAL SCREWLOCK
PART NUMBER 71433-0002

SEE SHEET 1 EC NO: UCP2012-3896 DRWN:BBARKER 2012/05/29 CHKD:MMOLFE APPR:SMILLER 2012/08/31	QUALITY SYMBOLS	GENERAL TOLERANCES (UNLESS SPECIFIED)	DIMENSION STYLE	SCALE	DESIGN UNITS	THIRD ANGLE PROJECTION
	▽=0	mm INCH	MM ONLY	4:1	METRIC	
	▽=0	4 PLACES ± --- ± ---	DRAWN BY DATE	TITLE		
	▽=0	3 PLACES ± --- ± ---	KSTILES 11/14/2002	VHDCI RIGHT ANGLE ASSEMBLY		
	2 PLACES ± 0.13 ± ---	CHECKED BY DATE	molex SD-71430-015			
	1 PLACE ± 0.25 ± ---	KSTILES 11/15/2002				
	0 PLACE ± ±	APPROVED BY DATE	SHEET NO. 2 OF 3			
		MATERIAL NO.	THIS DRAWING CONTAINS INFORMATION THAT IS PROPRIETARY TO MOLEX INCORPORATED AND SHOULD NOT BE USED WITHOUT WRITTEN PERMISSION			
		ANGULAR ±1/2°	SEE TABLE			
		DRAFT WHERE APPLICABLE MUST REMAIN WITHIN DIMENSIONS	DOCUMENT NO. SD-71430-015			

PCB THICKNESS	PART NUMBER	TAIL LENGTH "T" +0.50/-0.25	ENHANCED GROUND TABS	SCREWLOCKS (SEE GUIDELINE FOR CHOOSING A SCREWLOCK ON SHEET 3)	TAIL LOCATION "A"	PCB HOLE LOCATION "B"
1.60		2.08	NO	NONE	5.50	6.50 MAXIMUM
1.60		2.08	NO	71433-2002 LOOSE IN BAGS		
1.60		2.08	YES	NONE		
1.60		2.08	YES	71433-2002 LOOSE IN BAGS		
2.36		2.71	NO	NONE		
2.36		2.71	NO	71433-2002 INSTALLED		
2.36		2.71	YES	NONE		
2.36		2.71	YES	71433-2002 INSTALLED		
2.36		2.71	NO	71433-2002 LOOSE IN BAGS		
2.36	71430-3019	2.71	YES	71433-2002 LOOSE IN BAGS		
2.79	71430-3020	3.62	YES	71433-2002 LOOSE IN BAGS	5.30	6.30 MAXIMUM
2.36		2.71	YES	NONE		
1.60		2.08	YES	NONE		

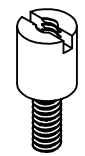
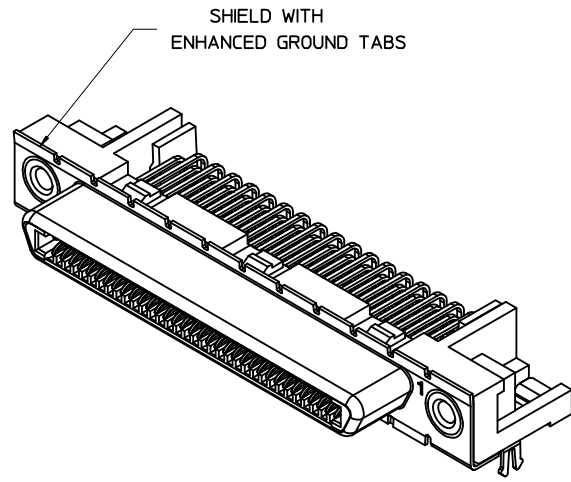
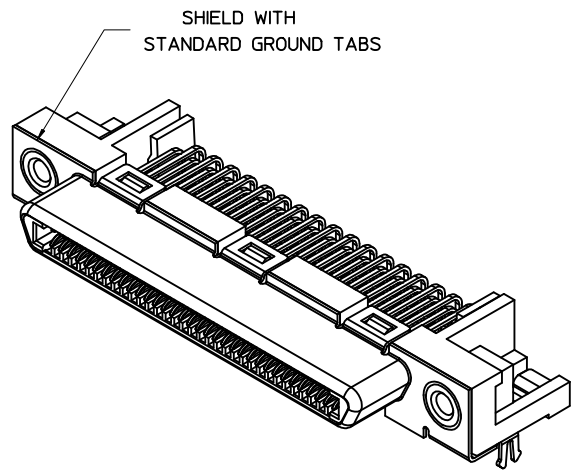

OPTIONAL SCREWLOCK
PART NUMBER 71433-2002 SHOWN
(SEE GUIDELINE FOR CHOOSING
A SCREWLOCK ON SHEET 3)

SEE SHEET 1 EC NO: UCP2015-5280 DRWN:TIBARRA 2015/06/12 CHKD:BBARKER 2015/06/30 APPR:SMILLER 2015/07/20	QUALITY SYMBOLS 	GENERAL TOLERANCES (UNLESS SPECIFIED)		DIMENSION STYLE MM ONLY		SCALE 4:1	DESIGN UNITS METRIC	THIRD ANGLE PROJECTION		
		4 PLACES ± ---	± ---	DRAWN BY BBARKER	DATE 2011/02/17	VHDCI RIGHT ANGLE ASSEMBLY				
		3 PLACES ± ---	± ---	CHECKED BY BSMART	DATE 2011/02/17					
		2 PLACES ± 0.13	± ---	APPROVED BY SMILLER	DATE 2011/02/25	molex DOCUMENT NO. SD-71430-3000 SHEET NO. 2 OF 3				
		1 PLACE ± 0.25	± ---	DRAFT WHERE APPLICABLE MUST REMAIN WITHIN DIMENSIONS						
0 PLACE ±	±	ANGULAR ±1/2°		MATERIAL NO. SEE TABLE		THIS DRAWING CONTAINS INFORMATION THAT IS PROPRIETARY TO MOLEX INCORPORATED AND SHOULD NOT BE USED WITHOUT WRITTEN PERMISSION				

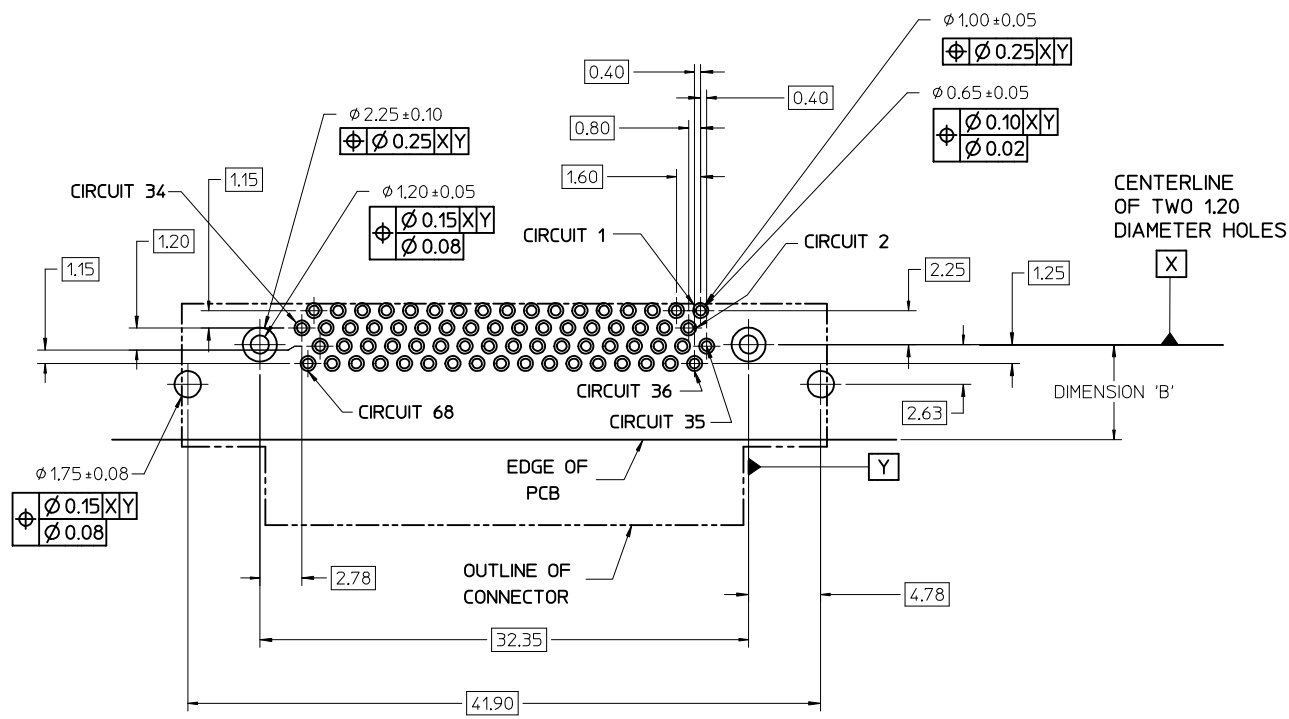

NOTES:

1. FOR FULL MATE WITH PLUG, PANEL THICKNESS SHOULD NOT EXCEED 1.0mm.

FUNCTIONAL MATING WITH MOLEX PLUG CAN STILL BE MAINTAINED WITH PANELS AS THICK AS 2.5mm (BUT PLUG AND RECEPTACLE WILL NOT BE FULLY MATED).

2. GUIDELINE FOR CHOOSING A MOLEX SCREWLOCK:

PANEL THICKNESS	RECOMMENDED SCREWLOCK
LESS THAN OR EQUAL TO 1.00 MM	71433-2002
1.01 TO 2.15 MM	71433-2010

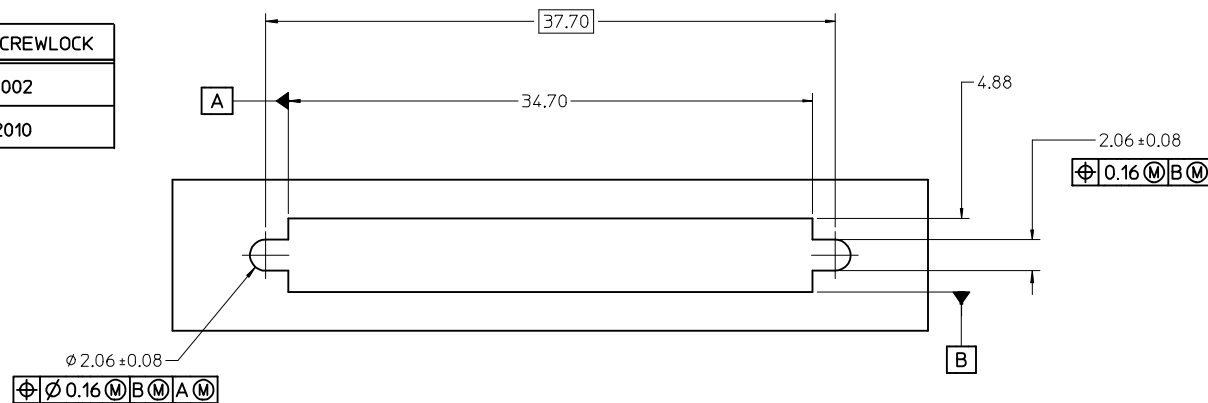

SEE SHEET 1 EC NO: UCP2015-5280 DRWN: TIBARRA 2015/06/12 CHKD: BBARKER 2015/06/30 APPR: SMILLER 2015/07/20 DESCRIPTION REV	QUALITY SYMBOLS	GENERAL TOLERANCES (UNLESS SPECIFIED)	DIMENSION STYLE	SCALE	DESIGN UNITS	THIRD ANGLE PROJECTION
	▽=0	mm INCH	MM ONLY	4:1	METRIC	
	▽=0	4 PLACES ± --- ± ---	DRAWN BY DATE			VHDCI RIGHT ANGLE ASSEMBLY molex
	▽=0	3 PLACES ± --- ± ---	BBARKER 2011/02/17			
		2 PLACES ± 0.13 ± ---	CHECKED BY DATE			SD-71430-3000 DOCUMENT NO.
	1 PLACE ± 0.25 ± ---	BSMART 2011/02/17				
	0 PLACE ± ±	APPROVED BY DATE			SHEET NO. 3 OF 3	
		SMILLER 2011/02/25				
		ANGULAR ±1/2°	MATERIAL NO.			
		DRAFT WHERE APPLICABLE MUST REMAIN WITHIN DIMENSIONS	SEE TABLE			
			SIZE			
			THIS DRAWING CONTAINS INFORMATION THAT IS PROPRIETARY TO MOLEX INCORPORATED AND SHOULD NOT BE USED WITHOUT WRITTEN PERMISSION			