

13 12 11 10 9 8 7 6 5 4 3 2 1

J  
I  
H  
G  
F  
E  
D  
C  
B  
A

J  
I  
H  
G  
F  
E  
D  
C  
B  
A

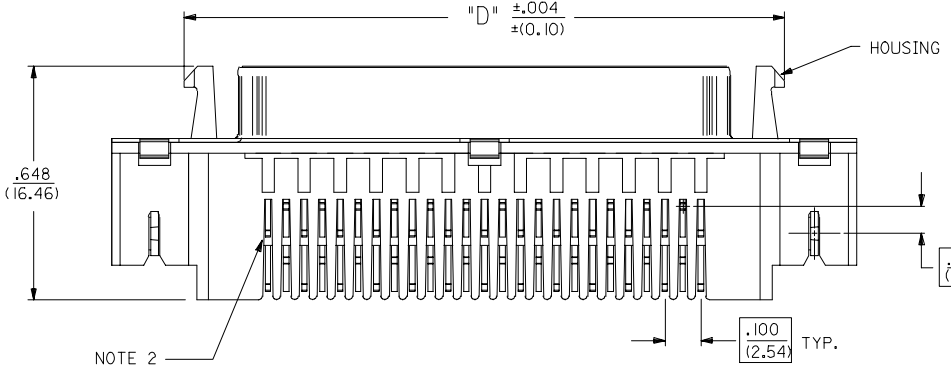
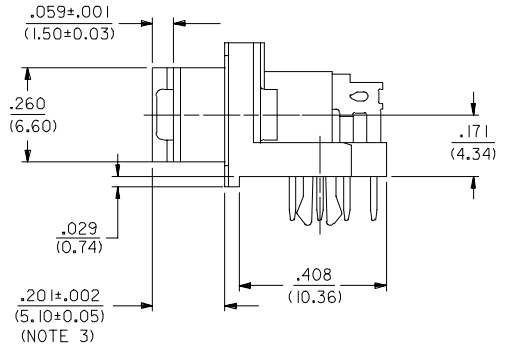
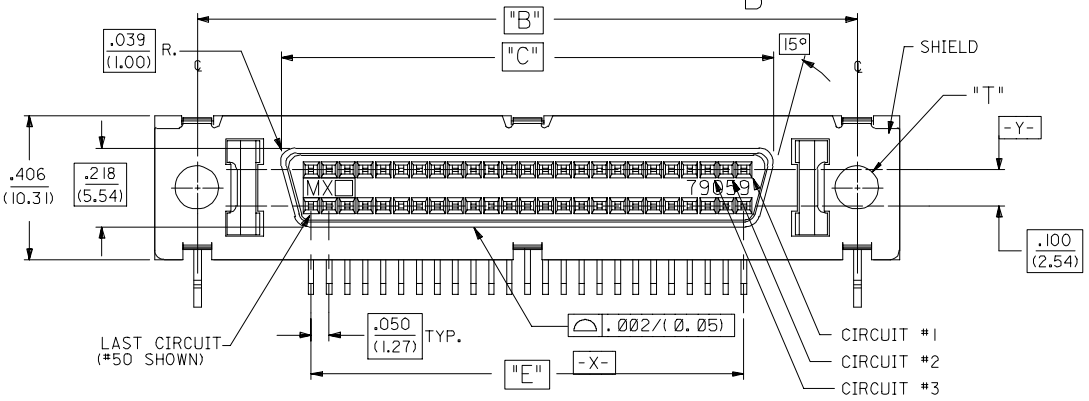
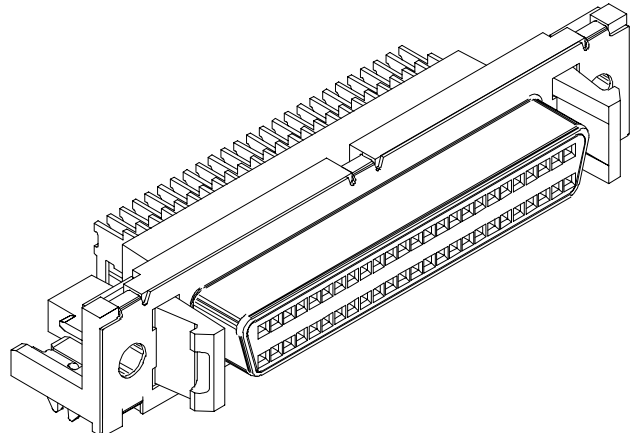
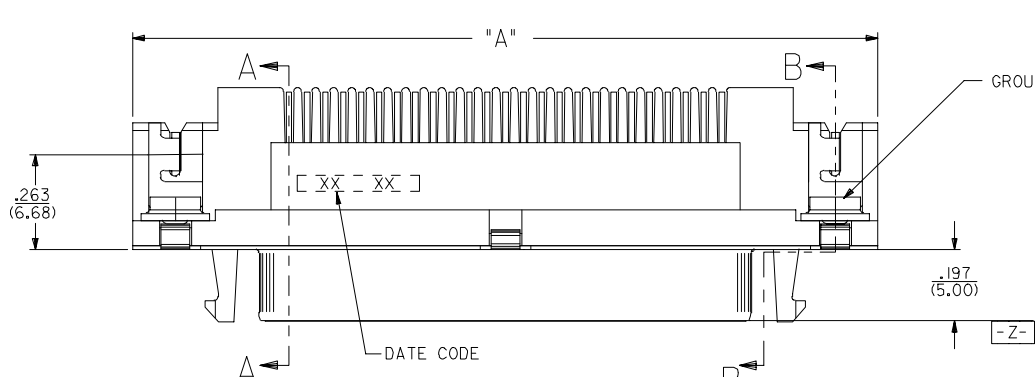

- NOTES:**
- SEE SHEET 4 & 5 FOR CHARTED DIMENSIONS AND PART NUMBERS.
  - FOR FIXED TAIL / PCB PATTERN AT LAST CIRCUIT POSITIONS REFER TO SECTION A-A ON SHEET 2 AND PCB LAYOUTS ON SHEET 3.
  - THIS DIMENSION TO MEET SPECIFICATIONS AFTER SHIELD IS FULLY SEATED TO HOUSING AS A RESULT OF A BRACKET OR PANEL.
  - REFER TO PS-79058 PRODUCT SPEC. FOR ELECTRICAL, MECHANICAL AND ENVIRONMENTAL SPECIFICATIONS.
  - MATERIAL:  
RECEPTACLE HOUSING: GLASS FILLED LIQUID CRYSTAL POLYMER; COLOR-BLACK; UL 94V-0  
CONTACTS: PHOSPHOR BRONZE  
SHIELD: STEEL WITH BRIGHT NICKEL OVER COPPER FLASH (OPTIONAL)  
GROUNDING CLIP: BRASS WITH TIN OVER NICKEL PLATE
  - PACKAGING:  
PARTS PACKAGED IN TUBES PER PK-70873-0207

5	T
4	T
3	S
2	S
1	T
SHT.	REV.

**TERMINAL FINISH:**  
SELECTIVE GOLD: THICKNESS= 30 MICROINCHES/(0.76 MICROMETERS) MINIMUM.  
SELECTIVE TIN: THICKNESS= 75 MICROINCHES/(1.90 MICROMETERS) MINIMUM.  
NICKEL UNDERPLATE OVERALL.

**NOTE FOR LEAD FREE CONVERSION:**  
THE PRIMARY SHIPPING CARTON WILL BE LABELED 'COMPLIANT TO ROHS DIRECTIVE 2002/95/EC AND ELV ANNEX II OF DIRECTIVE 2000/53/EC'. CARTONS WITHOUT THIS LABEL MAY CONTAIN PRODUCT WITH LEAD.

REMOVE OBSOLETE #S	DESCRIPTION	QUALITY SYMBOLS
FC NO: UCP2006-2901	2006/06/12	▽=0
DRWNS:BARRA	2006/06/12	▽=0
CHKD:BBARKER	2006/06/12	
APPR:SMILLER	2006/06/14	

GENERAL TOLERANCES (UNLESS SPECIFIED)	DIMENSION STYLE		SCALE	DESIGN UNITS	THIRD ANGLE PROJECTION
	mm	INCH	4:1	INCH	
4 PLACES ± --- ± ---	DRAWN BY		DATE	TITLE	
3 PLACES ± --- ± .005	JLONG		03/27/1989	SCSI SHIELDED RECEPTACLE ASSEMBLY WITH LATCHES	
2 PLACES ± 0.13 ± ---	CHECKED BY		DATE	MOLEX INCORPORATED	
1 PLACE ± --- ± ---	BOWEN		03/27/1989		
ANGULAR ±1/2°	APPROVED BY		DATE	MATERIAL NO. DOCUMENT NO. SHEET NO.	
	DJB		03/27/1989	SDA-79059-2*** 1 OF 5	
DRAFT WHERE APPLICABLE MUST REMAIN WITHIN DIMENSIONS	SEE TABLE		THIS DRAWING CONTAINS INFORMATION THAT IS PROPRIETARY TO MOLEX INCORPORATED AND SHOULD NOT BE USED WITHOUT WRITTEN PERMISSION		

12 11 10 9 8 7 6 5 4 3 2 1

13 12 11 10 9 8 7 6 5 4 3 2 1

J  
I  
H  
G  
F  
E  
D  
C  
B  
A

J  
I  
H  
G  
F  
E  
D  
C  
B  
A

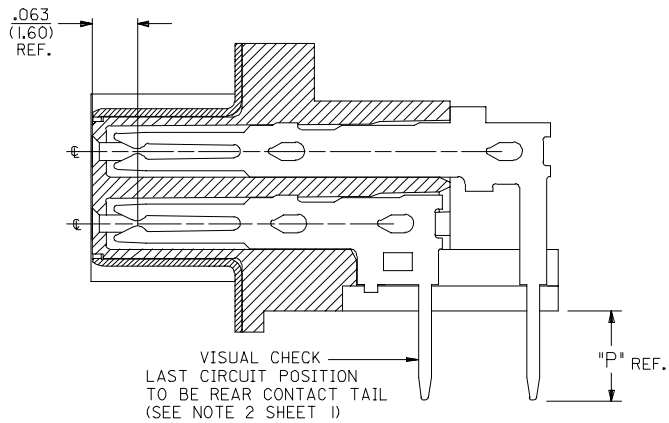

SECTION A-A  
68 CIRCUIT TYPE II TAIL VERSION  
50 CIRCUIT

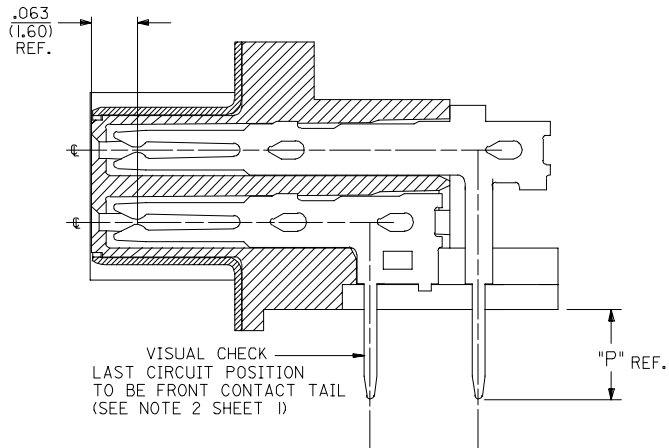

SECTION A-A  
68 CIRCUIT TYPE I TAIL VERSION ONLY

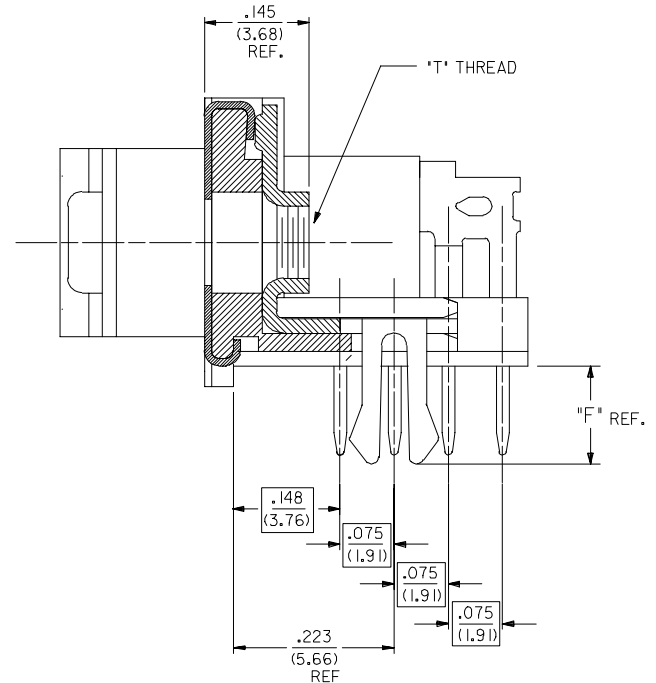

SECTION B-B

⌀ .006 / ( 0.15 ) M Z X Y

.024 ± .002  
(0,61 ± 0,05)

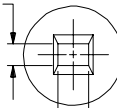

⌀ .006 / ( 0.15 ) M Z Y X

.034 ± .003  
(0,86 ± 0,08)

PIN WINDOW DETAIL  
SCALE 10:1

CHG TYPE I & II DESC EC NO: UCP2005-1072 DRWNSMART 2005/03/11 CHKD:BBARKER 2005/03/14 APPR:SMILLER 2005/03/28	QUALITY SYMBOLS 	GENERAL TOLERANCES (UNLESS SPECIFIED)		DIMENSION STYLE IN/MM	SCALE 8:1	DESIGN UNITS INCH	THIRD ANGLE PROJECTION	
		mm      INCH	DRAWN BY JLONG	DATE 04/14/1989	TITLE SALES ASSEMBLY SCS1 SHIELDED RECEPTACLE WITH LATCHES			
		4 PLACES ± --- ± --- 3 PLACES ± --- ± .005 2 PLACES ± 0.13 ± --- 1 PLACE ± --- ± ---	CHECKED BY BOWEN	DATE 04/14/1989	MOLEX INCORPORATED			
		ANGULAR ±1/2°	APPROVED BY DJB	DATE 04/14/1989	MATERIAL NO. SEE TABLE	DOCUMENT NO. SDA-79059-2***	SHEET NO. 2	
DRAFT WHERE APPLICABLE MUST REMAIN WITHIN DIMENSIONS		SIZE 		THIS DRAWING CONTAINS INFORMATION THAT IS PROPRIETARY TO MOLEX INCORPORATED AND SHOULD NOT BE USED WITHOUT WRITTEN PERMISSION				

12 11 10 9 8 7 6 5 4 3 2 1

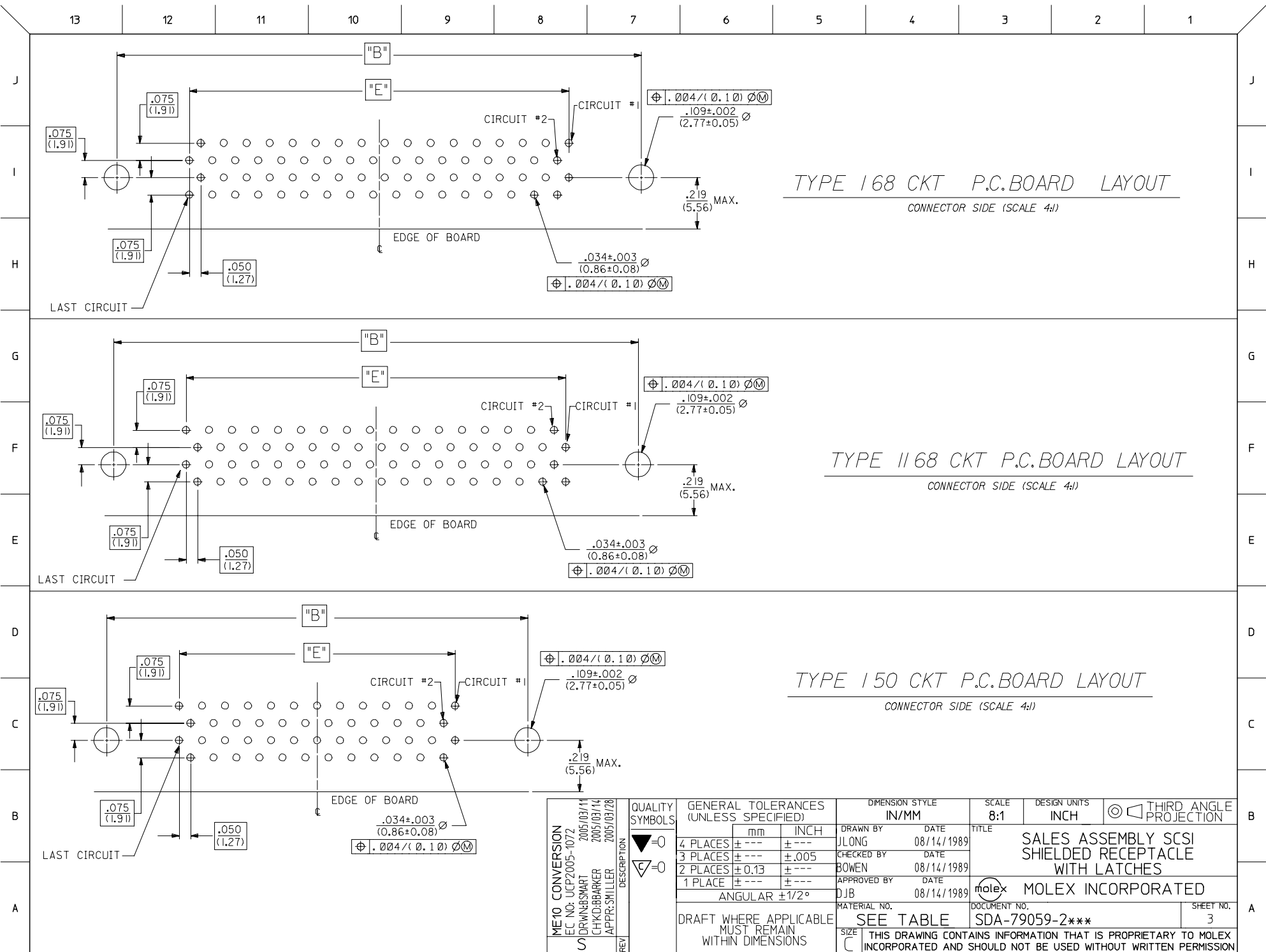

TYPE 168 CKT P.C.BOARD LAYOUT  
CONNECTOR SIDE (SCALE 4:1)

TYPE 1168 CKT P.C.BOARD LAYOUT  
CONNECTOR SIDE (SCALE 4:1)

TYPE 150 CKT P.C.BOARD LAYOUT  
CONNECTOR SIDE (SCALE 4:1)

ME10 CONVERSION FC NO: UCP2005-1072 2005/03/14 DRAWN BY: CHIKIDBARKER 2005/03/14 APPR: SMILLER 2005/03/28	QUALITY SYMBOLS ▽=0 ▽=0	GENERAL TOLERANCES (UNLESS SPECIFIED)	DIMENSION STYLE IN/MM	SCALE 8:1	DESIGN UNITS INCH	THIRD ANGLE PROJECTION
REV	DESCRIPTION	mm	INCH	DRAWN BY JLONG	DATE 08/14/1989	TITLE SALES ASSEMBLY SCSI SHIELDED RECEPTACLE WITH LATCHES
		4 PLACES ± ---	± ---	CHECKED BY BOWEN	DATE 08/14/1989	MOLEX INCORPORATED
		3 PLACES ± ---	± .005	APPROVED BY DJB	DATE 08/14/1989	
		2 PLACES ± 0.13	± ---	MATERIAL NO.	DOCUMENT NO.	SHEET NO. 3
		1 PLACE ± ---	± ---	SEE TABLE		SDA-79059-2***
		ANGULAR ±1/2°		THIS DRAWING CONTAINS INFORMATION THAT IS PROPRIETARY TO MOLEX INCORPORATED AND SHOULD NOT BE USED WITHOUT WRITTEN PERMISSION		

TYPE II TAIL PATTERN

ASSEMBLIES WITH .078 DIAMETER END HOLES IN HOUSING AND #2-56 GND CLIPS

J	EDP/ITEM NUMBER	CKT. SIZE	HOUSING HOLE DIA.	DIM. T GND CLIP THREAD	DIM. A		DIM. B		DIM. C		DIM. D		DIM. E		DIM. F		DIM. P		RECMD PCB	
					INCH	MM	INCH	MM	INCH	MM	INCH	MM	INCH	MM	INCH	MM	INCH	MM	INCH	MM
	015-87-6023	68	.078	2-56	2.515	63.88	2.280	57.91	1.816	46.13	2.115	53.72	1.650	41.91	.105	2.67	.125	3.18	.062	1.57
X		68	.078	2-56	2.515	63.88	2.280	57.91	1.816	46.13	2.115	53.72	1.650	41.91	.136	3.45	.125	3.18	.093	2.36

ASSEMBLIES WITH .105 DIAMETER END HOLES IN HOUSING AND #4-40 AND CUSTOM GND CLIPS

H	EDP/ITEM NUMBER	CKT. SIZE	HOUSING HOLE DIA.	DIM. T GND CLIP THREAD	DIM. A		DIM. B		DIM. C		DIM. D		DIM. E		DIM. F		DIM. P		RECMD PCB	
					INCH	MM	INCH	MM	INCH	MM	INCH	MM	INCH	MM	INCH	MM	INCH	MM	INCH	MM
	015-87-6020	68	.105	4-40	2.515	63.88	2.280	57.91	1.816	46.13	2.115	53.72	1.650	41.91	.105	2.67	.125	3.18	.062	1.57
X		68	.105	4-40	2.515	63.88	2.280	57.91	1.816	46.13	2.115	53.72	1.650	41.91	.136	3.45	.125	3.18	.093	2.36

X- NOT TOOLED

TYPE I TAIL PATTERN

ASSEMBLIES WITH .078 DIAMETER END HOLES IN HOUSING AND #2-56 GND CLIPS

E	EDP/ITEM NUMBER	CKT. SIZE	HOUSING HOLE DIA.	DIM. T GND CLIP THREAD	DIM. A		DIM. B		DIM. C		DIM. D		DIM. E		DIM. F		DIM. P		RECMD PCB	
					INCH	MM	INCH	MM	INCH	MM	INCH	MM	INCH	MM	INCH	MM	INCH	MM	INCH	MM
	79059-2900	68	.078	2-56	2.515	63.88	2.280	57.91	1.816	46.13	2.115	53.72	1.650	41.91	.105	2.67	.125	3.18	.062	1.57
X		50	.078	2-56	2.065	52.54	1.830	46.48	1.366	34.69	1.665	42.29	1.200	30.48	.136	3.45	.125	3.18	.093	2.36
	015-87-6010	50	.078	2-56	2.065	52.54	1.830	46.48	1.366	34.69	1.665	42.29	1.200	30.48	.105	2.67	.125	3.18	.062	1.57

ASSEMBLIES WITH .105 DIAMETER END HOLES IN HOUSING AND #4-40 AND CUSTOM GND CLIPS

X		50	.105	4-40	2.065	52.54	1.830	46.48	1.366	34.69	1.665	42.29	1.200	30.48	.136	3.45	.125	3.18	.093	2.36
	015-87-6050	50	.105	4-40	2.065	52.54	1.830	46.48	1.366	34.69	1.665	42.29	1.200	30.48	.105	2.67	.125	3.18	.062	1.57

X- NOT TOOLED

NOTE: ASSEMBLIES LISTED ON THIS SHEET HAVE A SMALLER HOLE DIAMETER FOR INSERTION OF SCREWLOCKS USING A POWER DRIVER.

REMOVE OBSOLETEL #S FC NO: UCP2006-2901 DRAWN:MS/BARRA 2006/06/12 CHKD:BBARKER 2006/06/12 APPR:SMILLER 2006/06/14 REV:	QUALITY SYMBOLS	GENERAL TOLERANCES (UNLESS SPECIFIED)	DIMENSION STYLE	SCALE	DESIGN UNITS	THIRD ANGLE PROJECTION
	$\nabla=0$ $\nabla=0$	mm INCH	IN/MM	---	INCH	
		4 PLACES ± --- ± --- 3 PLACES ± --- ± --- 2 PLACES ± --- ± --- 1 PLACE ± --- ± --- ANGULAR ±1/2°	DRAWN BY DATE DCB 08/15/1991 CHECKED BY DATE CAB 08/15/1991 APPROVED BY DATE CAB 08/15/1991	TITLE SALES ASSEMBLY SCSI SHIELDED RECEPTACLE WITH LATCHES		
		DRAFT WHERE APPLICABLE MUST REMAIN WITHIN DIMENSIONS	MATERIAL NO. SEE TABLE SIZE C	DOCUMENT NO. SDA-79059-2*** SHEET NO. 4		

TYPE II TAIL PATTERN

ASSEMBLIES WITH .120 DIAMETER END HOLES IN HOUSING AND #4-40 GND CLIPS

J	EDP/ITEM NUMBER	CKT. SIZE	HOUSING HOLE DIA.	DIM. T GND CLIP THREAD	DIM. A		DIM. B		DIM. C		DIM. D		DIM. E		DIM. F		DIM. P		REC'D PCB	
					INCH	MM	INCH	MM	INCH	MM	INCH	MM	INCH	MM	INCH	MM	INCH	MM	INCH	MM
	79059-2702	68	.120	4-40	2.515	63.88	2.280	57.91	1.816	46.13	2.115	53.72	1.650	41.91	.105	2.67	.125	3.18	.062	1.57
X		68	.120	4-40	2.515	63.88	2.280	57.91	1.816	46.13	2.115	53.72	1.650	41.91	.136	3.45	.125	3.18	.093	2.36

ASSEMBLIES WITH .120 DIAMETER END HOLES IN HOUSING AND #2-56 AND CUSTOM GND CLIPS

X		68	.120	2-56	2.515	63.88	2.280	57.91	1.816	46.13	2.115	53.72	1.650	41.91	.105	2.67	.125	3.18	.062	1.57
X		68	.120	2-56	2.515	63.88	2.280	57.91	1.816	46.13	2.115	53.72	1.650	41.91	.136	3.45	.125	3.18	.093	2.36

X - NOT TOOLED

TYPE I TAIL PATTERN

ASSEMBLIES WITH .120 DIAMETER END HOLES IN HOUSING AND #4-40 GND CLIPS

G	EDP/ITEM NUMBER	CKT. SIZE	HOUSING HOLE DIA.	DIM. T GND CLIP THREAD	DIM. A		DIM. B		DIM. C		DIM. D		DIM. E		DIM. F		DIM. P		REC'D PCB	
					INCH	MM	INCH	MM	INCH	MM	INCH	MM	INCH	MM	INCH	MM	INCH	MM	INCH	MM
	79059-2701	50	.120	4-40	2.065	52.54	1.830	46.48	1.366	34.69	1.665	42.29	1.200	30.48	.105	2.67	.125	3.18	.062	1.57
X		50	.120	4-40	2.065	52.54	1.830	46.48	1.366	34.69	1.665	42.29	1.200	30.48	.136	3.45	.125	3.18	.093	2.36

ASSEMBLIES WITH .120 DIAMETER END HOLES IN HOUSING AND #2-56 AND CUSTOM GND CLIPS

X		50	.120	2-56	2.065	52.54	1.830	46.48	1.366	34.69	1.665	42.29	1.200	30.48	.105	2.67	.125	3.18	.062	1.57
X		50	.120	2-56	2.065	52.54	1.830	46.48	1.366	34.69	1.665	42.29	1.200	30.48	.136	3.45	.125	3.18	.093	2.36

X - NOT TOOLED

NOTE: ASSEMBLIES LISTED ON THIS SHEET HAVE A LARGER HOLE DIAMETER FOR INSERTION OF SCREWLOCKS USING A MANUAL DRIVER.

REMOVE OBSOLETE #S FC NO. UCP2006-2901 DRAWN BY: BARRA 2006/06/12 CHK'D: BARKER 2006/06/12 APP'R: SMILLER 2006/06/14	QUALITY SYMBOLS ▽=0 ▽=0	GENERAL TOLERANCES (UNLESS SPECIFIED)		DIMENSION STYLE IN/MM		SCALE ---	DESIGN UNITS INCH	THIRD ANGLE PROJECTION		
		4 PLACES ± --- ± ---	3 PLACES ± --- ± ---	2 PLACES ± --- ± ---	1 PLACE ± --- ± ---	DRAWN BY JLONG	DATE 01/28/1997	TITLE SALES ASSEMBLY SCSI SHIELDED RECEPTACLE WITH LATCHES		
		ANGULAR ±1/2°				APPROVED BY DJB	DATE 01/28/1997	molex MOLEX INCORPORATED		
		DRAFT WHERE APPLICABLE MUST REMAIN WITHIN DIMENSIONS				MATERIAL NO. SEE TABLE		DOCUMENT NO. SDA-79059-2***	SHEET NO. 5	
THIS DRAWING CONTAINS INFORMATION THAT IS PROPRIETARY TO MOLEX INCORPORATED AND SHOULD NOT BE USED WITHOUT WRITTEN PERMISSION										