

MATERIAL NUMBER	ENG. NO.	MATERIAL NUMBER TAPE MOUNTED	ENG. NO.	STUD SIZE	"S" ±.005	"W" MAX	"C" MIN	"L" MAX
190730145	C-801-12	190730146	C-801-12T	12	.515 (13.08)	.760 (19.30)	.611 (15.52)	1.580 (40.13)
190730148	C-801-14	-----	-----	14	.265 (6.73)			
190730150	C-801-38	-----	-----	38	.390 (9.91)			
190730152	C-801-56	-----	-----	56	.328 (8.33)			
190730154	C-801-76	-----	-----	76	.453 (11.51)			
190730156	C-828-04	190730157	C-828-04T	04	.119 (3.02)	.385 (9.78)	.303 (7.70)	1.091 (27.71)
190730160	C-828-06	190730162	C-828-06T	06	.146 (3.71)			
190730165	C-828-08	190730167	C-828-08T	08	.173 (4.39)			
190730170	C-828-10	190730172	C-828-10T	10	.198 (5.03)			
190730175	C-828-14	-----	-----	14	.265 (6.73)			

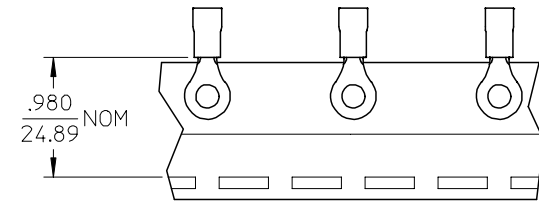
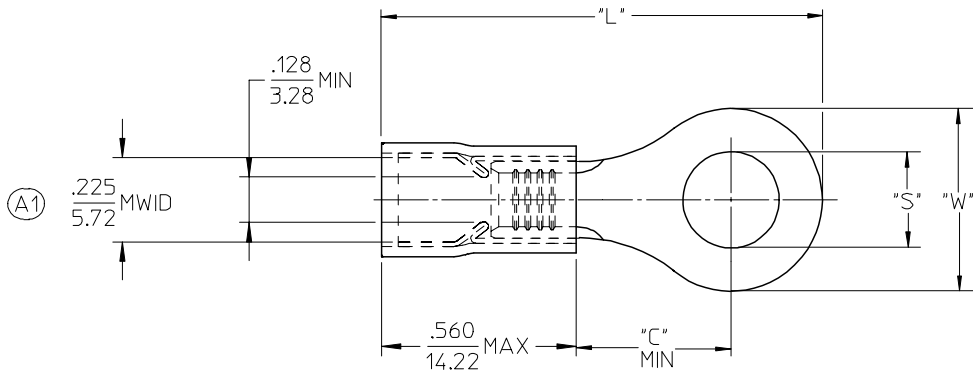

SALES DRAWING

- NOTES:
- MATERIAL: COPPER (.040/1.02) THICK. PLATING: ELECTROPLATE TIN
  - FERRULE: TIN PLATED BRASS
  - INSULATION: YELLOW NYLON
  - MWID=MAXIMUM WIRE INSULATION DIA.
  - ALL DIMENSIONS IN INCHES (MM).
  - WIRE SIZE: 12-10 AWG  
4.0-6.0 MM<sup>2</sup>

EC NO: ETC2006-0152 DRWN: ASAYDEH 2005/12/12 CHKD: JLOMASTR 2005/12/13 APPR: RDEROSS 2005/12/14	QUALITY SYMBOLS	GENERAL TOLERANCES (UNLESS SPECIFIED)	SCALE 4:1	DESIGN UNITS INCH	THIRD ANGLE PROJECTION	REVISE ON CAD ONLY
	DESCRIPTION ▼ - 0 ▽ - 0	mm	INCH	DIMENSION STYLE IN/MM		TITLE
		4 PLACES ± --- ± ---	3 PLACES ± --- ± .005	DRAWN BY DMYRICK	DATE 03/12/15	RING TONGUE TERMINAL AVIKRIMP, 800-SERIES 12-10 AWG
		2 PLACES ± 0.13 ± .01	1 PLACE ± 0.25 ± ---	CHECKED BY SBEITZEL	DATE 03/12/15	MOLEX INCORPORATED
REV A1	DRAFT WHERE APPLICABLE	ANGULAR ± 1 °	APPROVED BY RDEROSS	DATE 03/12/15	MATERIAL NO. SEE CHART	DOCUMENT NO. SD-19073-007
	MUST REMAIN WITHIN DIMENSIONS		THIS DRAWING CONTAINS INFORMATION THAT IS PROPRIETARY TO MOLEX INCORPORATED AND SHOULD NOT BE USED WITHOUT WRITTEN PERMISSION		SHEET NO. 1 OF 1	