

10	9	8	7	6	5	4	3	2	19070
MATERIAL NO. LOOSE PIECE	ENG. NO.	MATERIAL NO. TAPE MOUNTED	ENG. NO.	STUD SIZE	±.003 "S"	"W" MAX.	"C" MIN.	"L" MAX.	
190700054	BB-218-10X	-----	-----	10	.198 (5.03)	.544 (13.82)	.535 (13.59)	1.261 (32.03)	
190700057	BB-218-14X	190700058	BB-218-14XT	14	.265 (6.73)				
190700059	BB-218-38X	190700061	BB-218-56XT	38	.390 (9.91)				
190700063	BB-218-56X	190700064	BB-218-38XT	56	.328 (8.33)				
190700065	BB-223-02X	190700066	BB-223-02XT	2	.094 (2.39)	.260 (6.60)	.209 (5.31)	.785 (19.94)	
190700067	BB-223-04X	190700068	BB-223-04XT	4	.119 (3.02)				
190700069	BB-223-06X	190700070	BB-223-06XT	6	.146 (3.71)				
190700071	BB-223-08X	190700072	BB-223-08XT	8	.173 (4.39)				
190700073	BB-225-10X	190700074	BB-225-10XT	10	.198 (5.03)	.477 (12.11)	.388 (9.86)	1.062 (26.97)	
190700075	BB-225-14X	190700076	BB-225-14XT	14	.265 (6.73)				
190700078	BB-225-56X	190700079	BB-225-56XT	56	.328 (8.33)				
190700081	BB-237-04X	190700082	BB-237-04XT	4	.119 (3.02)				
190700083	BB-237-06X	190700084	BB-237-06XT	6	.146 (3.71)	.322 (8.18)	.275 (6.98)	.870 (22.10)	
190700086	BB-237-08X	190700087	BB-237-08XT	8	.173 (4.39)				
190700090	BB-237-10X	190700092	BB-237-10XT	10	.198 (5.03)				
190700097	BB-239-06X	190700098	BB-239-06XT	6	.146 (3.71)				
190700099	BB-239-08X	190700100	BB-239-08XT	8	.173 (4.39)	.352 (8.94)	.305 (7.75)	.921 (23.39)	
190700102	BB-239-10X	190700104	BB-239-10XT	10	.198 (5.03)				

ENG. NO.  
BB-218-\*\*\*XT ONLY

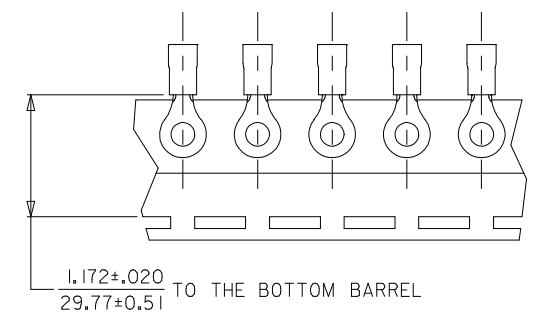
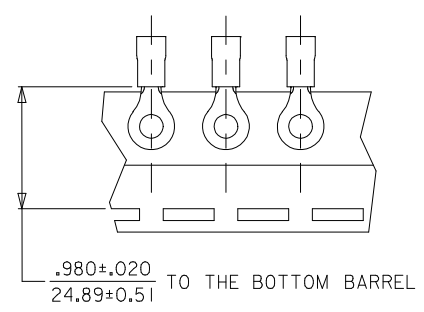
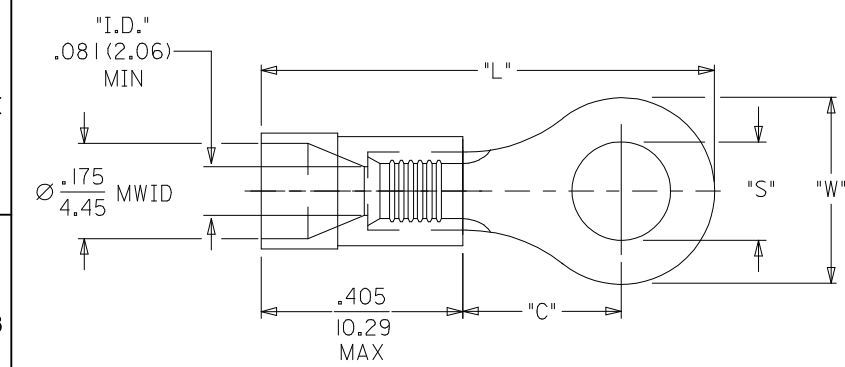

SALES DRAWING

- NOTE(S):
1. MATERIAL: COPPER (.031/0.79 THICK)  
PLATING: ELECTROPLATE TIN
  2. FERRULE: TIN-PLATED BRASS
  3. INSULATION: BLUE MOLDED PVC.
  4. MWID=MAXIMUM WIRE INSULATION DIA.  
WIRE SIZE: 16-14 AWG  
1.0 - 2.5 MM<sup>2</sup>
  5. ALL DIMENSIONS IN INCHES (MM).
  6. PARTS ARE ROHS COMPLIANT.

ADDED NOTE 6 EC NO: IFG2013-1831 DRWN:GROJAS01 2013/05/28 CHKD:JMACNEIL 2013/05/28 APPR:JMACNEIL 2013/06/06 A	QUALITY SYMBOLS	GENERAL TOLERANCES (UNLESS SPECIFIED)	SCALE	DESIGN UNITS	THIRD ANGLE PROJECTION	REVISE ON CAD ONLY
		mm	INCH	DIMENSION STYLE		RING TONGUE TERMINAL INSULKRIMP 16-14 AWG
		4 PLACES ± --- ± ---	3 PLACES ± --- ± ---	IN/MM		
	DESCRIPTION C=0	2 PLACES ± --- ± ---	1 PLACE ± --- ± ---	DRAWN BY	DATE	MOLEX INCORPORATED SEE CHART SD-19070-008
ANGULAR ±1/2°		D.MYRICK	04/06/15	MATERIAL NO. SD-19070-008 DOCUMENT NO. SD-19070-008 SHEET NO. 1 OF 1		
DRAFT WHERE APPLICABLE		MUST REMAIN WITHIN DIMENSIONS	JMACNEIL	2013/05/28	THIS DRAWING CONTAINS INFORMATION THAT IS PROPRIETARY TO MOLEX INCORPORATED AND SHOULD NOT BE USED WITHOUT WRITTEN PERMISSION	