

10		9		8		7		6		5		4		3		2		1	
LOOSE PIECE				TAPE MOUNTED				STUD SIZE	"S" ±.005/ 0.13	"W" ±.010/ 0.25	"C" MIN	"L" MAX	"H" ±.020/0.51						
MATERIAL NO.	ENGINEERING P/N	MATERIAL NO.	ENGINEERING P/N																
190700143	C-236-06X	190700144	C-236-06XT	6	.146/ 3.70	.282/ 7.16	.306/ 7.77	1.04/ 26.3	.98/ 24.9										
190700145	C-236-08X	190700146	C-236-08XT	8	.173/ 4.39	.282/ 7.16	.306/ 7.77	1.04/ 26.3	.98/ 24.9										
190700117	C-228-04X	-	-	4	.119/ 3.02	.375/ 9.53	.303/ 7.70	1.08/ 27.4	-										
190700119	C-228-06X	190700120	C-228-06XT	6	.146/ 3.70	.375/ 9.53	.303/ 7.70	1.08/ 27.4	.98/ 24.9										
190700121	C-228-08X	190700122	C-228-08XT	8	.173/ 4.39	.375/ 9.53	.303/ 7.70	1.08/ 27.4	.98/ 24.9										
190700123	C-228-10X	190700125	C-228-10XT	10	.198/ 5.02	.375/ 9.53	.303/ 7.70	1.08/ 27.4	.98/ 24.9										
190700128	C-228-209X	-	-	5mm	.209/ 5.30	.375/ 9.53	.303/ 7.70	1.08/ 27.4	-										
190700130	C-230-10X	190700131	C-230-10XT	10	.198/ 5.02	.530/ 13.46	.393/ 9.98	1.25/ 31.6	.98/ 24.9										
190700132	C-230-14X	190700133	C-230-14XT	1/4"	.265/ 6.73	.530/ 13.46	.393/ 9.98	1.25/ 31.6	.98/ 24.9										
190700136	C-230-56X	190700137	C-230-56XT	5/16"	.328/ 8.33	.530/ 13.46	.393/ 9.98	1.25/ 31.6	.98/ 24.9										
190700148	C-240-10X	190700149	C-240-10XT	10	.198/ 5.02	.592/ 15.04	.466/ 11.84	1.35/ 34.3	1.17/ 29.8										
190700150	C-240-14X	190700151	C-240-14XT	1/4"	.265/ 6.73	.592/ 15.04	.466/ 11.84	1.35/ 34.3	1.17/ 29.8										
190700155	C-240-56X	190700156	C-240-56XT	5/16"	.328/ 8.33	.592/ 15.04	.466/ 11.84	1.35/ 34.3	1.17/ 29.8										
190700153	C-240-38X	190700154	C-240-38XT	3/8"	.390/ 9.90	.592/ 15.04	.466/ 11.84	1.35/ 34.3	1.17/ 29.8										
190700111	C-201-14X	-	-	1/4"	.265/ 6.73	.750/ 19.05	.611/ 15.52	1.58/ 40.0	-										
190700115	C-201-76X	190700116	C-201-76XT	7/16"	.453/ 11.50	.750/ 19.05	.611/ 15.52	1.58/ 40.0	1.30/ 33.0										
190700109	C-201-12X	190700110	C-201-12XT	1/2"	.515/ 13.08	.750/ 19.05	.611/ 15.52	1.58/ 40.0	1.30/ 33.0										

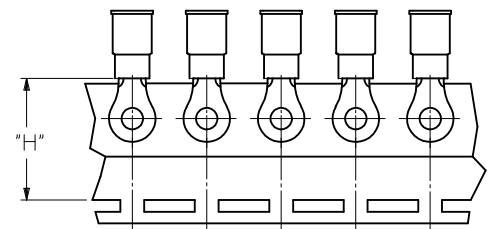
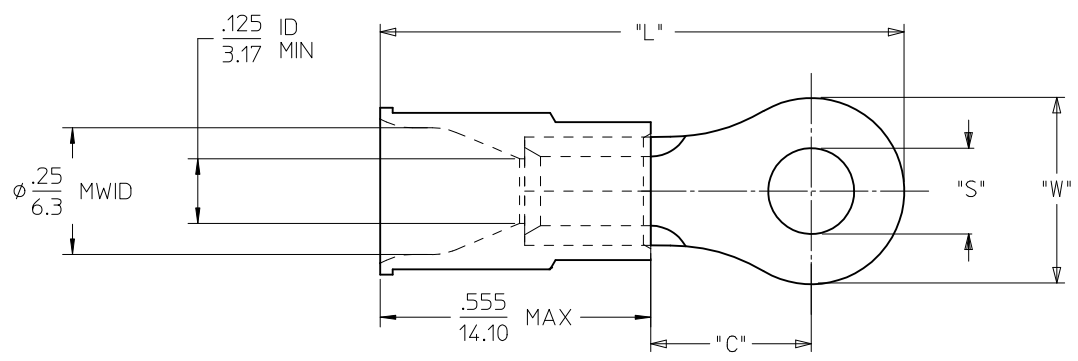

PARTS ON TAPE  
(NOTE: C-240 AND C-201 PARTS ARE DOUBLE-SPACED)

- NOTES:  
 1. MATERIALS:  
 TERMINAL: TIN-PLATED COPPER  
 INSULATION: PVC INSULATION, YELLOW  
 2. MWIDTH = MAXIMUM WIRE INSULATION DIAMETER  
 3. PARTS ARE ROHS COMPLIANT.

<b>REDRAW</b> EC NO: WNA2011-0252 DRAWN: ETHRODAHL 2011/01/24 CHKD: JMACNEIL 2011/01/24 APPR: JMACNEIL 2011/02/21 DESCRIPTION REV A	QUALITY SYMBOLS ▽=0 ▽=0	GENERAL TOLERANCES (UNLESS SPECIFIED) mm INCH 4 PLACES ± --- ± --- 3 PLACES ± --- ± .005 2 PLACES ± 0.13 ± .010 1 PLACE ± 0.25 ± .020 ANGULAR ± 1/2°	DIMENSION STYLE IN/MM DRAWN BY DATE ETHRODAHL 2011/01/24 CHECKED BY DATE JMACNEIL 2011/01/24 APPROVED BY DATE JMACNEIL 2011/02/21 MATERIAL NO.	SCALE --- DESIGN UNITS INCH THIRD ANGLE PROJECTION	TITLE RING TONGUE TERMINAL INSULKRIMP 12-10 AWG	MOLEX INCORPORATED	DOCUMENT NO. SD-19070-007	SHEET NO. 1 OF 1
	DRAFT WHERE APPLICABLE MUST REMAIN WITHIN DIMENSIONS		SEE CHART	THIS DRAWING CONTAINS INFORMATION THAT IS PROPRIETARY TO MOLEX INCORPORATED AND SHOULD NOT BE USED WITHOUT WRITTEN PERMISSION				