

"SIMM" P.C. BOARD LAYOUT

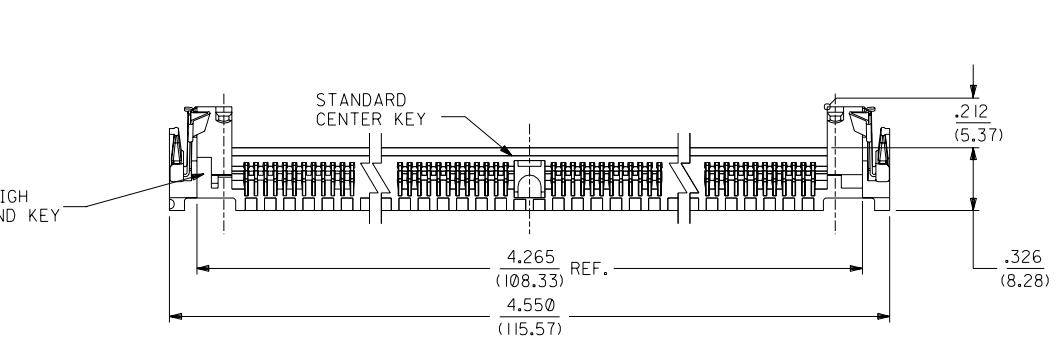
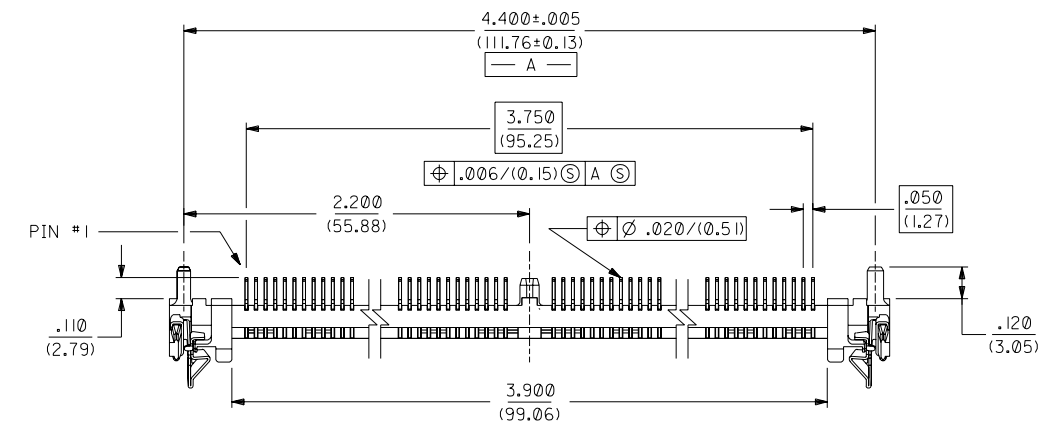

- NOTES:
- CARD SLOT ACCEPTS P.C. BOARDS $.050 +.004 / -.003$ THICK, MEASURED OVER CONTACT PADS. (1.27 +0.10 / -0.08)
 - PRODUCT SPEC PS-78954 APPLIES.
 - LOCATION OF LOWER CORNER OF MODULE BOARD.
 - CENTER PEG IS AN INTERFERENCE FIT TO RECOMMENDED P.C. BOARD HOLE.

MATERIALS:

HOUSING: LCP, GLASS FILLED, 94V-0. COLOR: BLACK.

LATCH: STAINLESS STEEL.

TERMINAL: PHOSPHOR BRONZE, POST PLATED

30μIN./(.76μm) MIN. GOLD IN CONTACT AREA AND 150μIN./(.381μm) MIN. TIN IN TAIL AREA OVER 75μIN./(.191μm) MIN. NICKEL OVERALL.

*THE PRIMARY SHIPPING CARTON WILL BE LABELED "COMPLIANT TO RoHS DIRECTIVE 2002/95/EC AND ELV ANNEX II OF DIRECTIVE 2000/53/EC". CARTONS WITHOUT THIS LABEL MAY CONTAIN PRODUCT WITH LEAD.

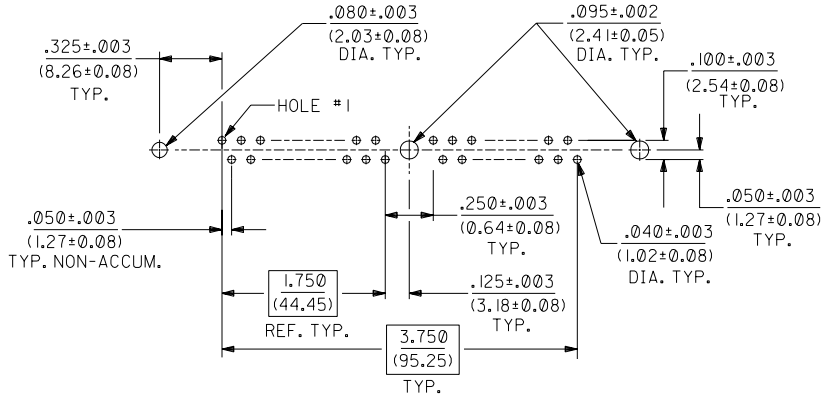

RECOMMENDED SOCKET P.C. BOARD HOLE PATTERN

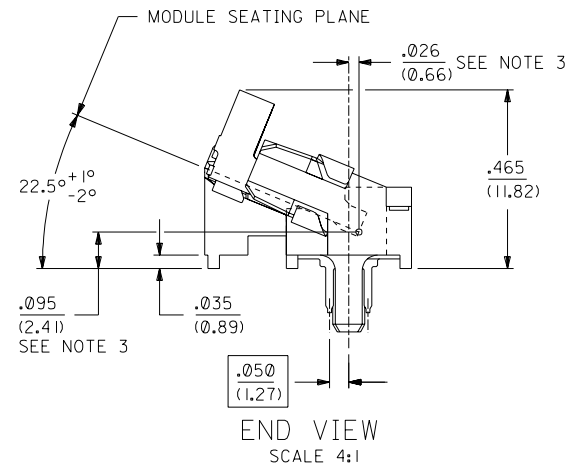

L	LEAD FREE UCP2004-1582 RWHITE 04/02/25
K	REVISED PER ECN #U51394 GMY 7-24-95
J	REVISED PEG LENGTH PER ECN #U30751 MJS 6-8-93
I	REMOVED TRACKING TOES PER ECN #U20914 PDB 06-17-92
H	REVISED NOTES PER ECN #U11964 PDB 10-03-91
G	CORRECT HOLE PATTERN PER ECN #U11922 PDB 09-25-91
F	REVISED MASTER PER ECN #U11822 PDB 09-04-91
E	.150 WAS .120 PER ECN #U110303 PDB 01-22-91
D	REVISED PER ECN #U100846 PDB 10-25-90
C	REVISED PER ECN #U100620 PDB 08-24-90
B	REVISED PER ECN #U100635 PDB 08-20-90
A	RELEASE TO MFG. PER ERO #30233 PDB 08-07-90

DIMENSIONS SHOWN (METRIC) INCH		▽ = 0 ▽ = 0		MFG. SH. REV. LTR. REVISIONS	
UNLESS OTHERWISE SPECIFIED TOLERANCES: ANGULAR ± 1/2°		REVISE ONLY ON CAD SYSTEM			
TITLE		SALES ASSEMBLY			
3 PLACE ± .010 ---		22.5° METAL LATCH HIGH KEY			
2 PLACE ± .014 ± 0.25		SINGLE ROW SIMM SOCKET			
1 PLACE --- ± 0.35		MOLEX INCORPORATED			
DRAFT WHERE APPLICABLE MUST REMAIN WITHIN DIMENSIONS		SHEET NO. DATE		1 OF 1 08/07/90	
PART NO.		U.S.A.		DRWG. NO.	
15-82-0675		60532		SDA-78964-7232	
DRWG. PDB		CHK'D. BY		FILE NAME	
BY		BY		S78964-18	
APPR. BY		SCALE		2: 1	
				THIS DRAWING CONTAINS INFORMATION THAT IS PROPRIETARY TO MOLEX INC. AND SHOULD NOT BE USED WITHOUT WRITTEN PERMISSION	
				DIV. SIZE	