

2578 - * - * * *

MATERIAL CODE
 (.28)/.0106 THK
 BLANK=BRASS
 B=PHOS BRONZE

WINDING SPEC.
 A=CHAIN, PER WINDING DETAIL "A"
 BLANK=CHAIN, PER WINDING DETAIL "B"
 L=LOOSE

PLATING CODE
 (PER SDES-88)

OPTIONS
 BLANK=AS SHOWN
 1 = WITH CAT EARS

(122) - OVERALL TIN: (0.00381)/.000150 MIN.
 OVER (0.00076)/.000030 MIN. NICKEL
 (154) - OVERALL TIN (0.00254)/.000100 MIN.
 OVER (0.00127)/.000050 MIN. NICKEL
 (224) - OVERALL MATTE TIN: (0.00508)/.000200 MIN.
 OVER (0.00127)/.000050 MIN. NICKEL
 (550) - SELECT GOLD: (0.00038)/.000015 MIN.
 OVERALL GOLD FLASH: (0.00005)/.000002 MIN.
 OVERALL NICKEL UNDERPLATE: (0.00076)/.000030 MIN.
 (555) - SELECT GOLD: (0.00038)/.000015 MIN.
 OVERALL NICKEL UNDERPLATE: (0.00076)/.000030 MIN.
 (558) - SELECT GOLD: (0.00076)/.000030 MIN.
 OVERALL GOLD FLASH: (0.00005)/.000002 MIN.
 OVERALL NICKEL UNDERPLATE: (0.00127)/.000050 MIN.
 (P909) - OVERALL HOT TIN DIP: (0.00254)/.000100 MIN

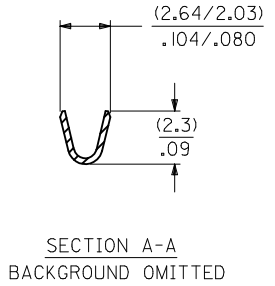
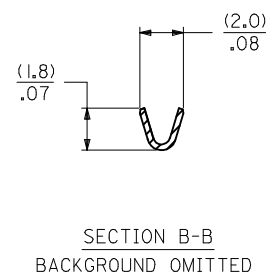
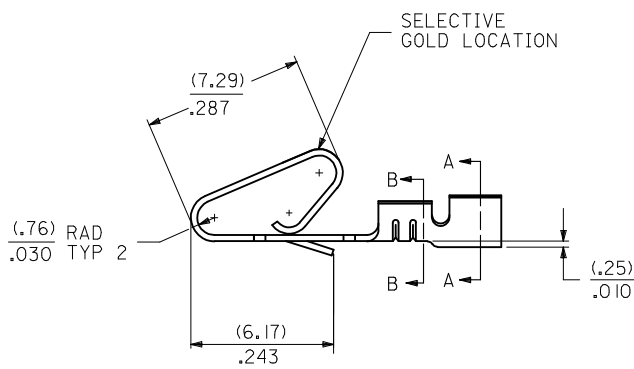
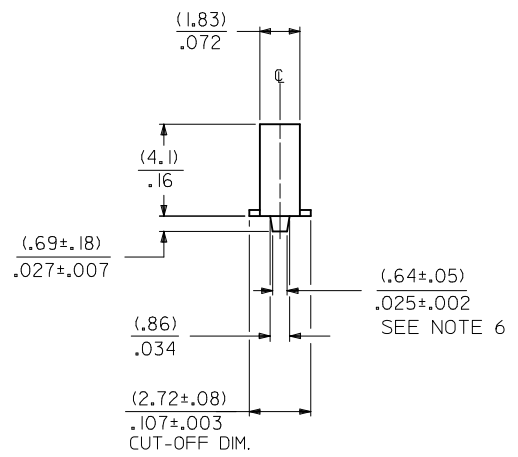

1. MATERIAL: SEE LEGEND
2. FINISH: SEE LEGEND
3. PRODUCT SPECIFICATION: PS-08-50
4. CRIMP ACCEPTS 22 TO 26 GA. WIRE WITH (1.65)/0.65 MAX INSULATION DIA.
5. DIMENSIONS GIVEN ACROSS CENTERLINES ARE SYMMETRICAL ABOUT THOSE CENTERLINES WITHIN HALF THE TOTAL TOLERANCE.
6. OPTIONAL DESIGN (.86±.05)/.034±.002
7. THIS PART CONFORMS TO CLASS B REQUIREMENTS OF COSMETIC SPECIFICATION PS-45499-002

ADD WINDING VIEW EC NO: UCP2014-4131 DRW:WIKIPPER 2014/04/07 CHKD:NGUYEN 2014/04/07 APPR:FSMITH 2014/04/21	QUALITY SYMBOLS	DESCRIPTION
	▽=0	
	▽=0	
	▽=0	
REV		

GENERAL TOLERANCES (UNLESS SPECIFIED)	
mm	INCH
4 PLACES ± --- ± ---	
3 PLACES ± --- ± .010	
2 PLACES ± 0.25 ± .014	
1 PLACE ± 0.36 ± ---	
0 PLACE ± --- ± ---	
ANGULAR ±1/2°	
DRAFT WHERE APPLICABLE MUST REMAIN WITHIN DIMENSIONS	

DIMENSION STYLE		SCALE	DESIGN UNITS	THIRD ANGLE PROJECTION
MM/IN		---	INCH	
DRAWN BY	DATE	TITLE		
PEREZ/AR	01/29/87	CRIMP TERMINAL		
CHECKED BY	DATE	(3.96)/.156 CENTERS		
PATEL	01/29/87	22 TO 26 GA WIRE		
APPROVED BY	DATE	molex		
FSMITH	2014/04/21	DOCUMENT NO. SD-2578		
MATERIAL NO. SEE CHART		SHEET NO. 1 OF 2		

THIS DRAWING CONTAINS INFORMATION THAT IS PROPRIETARY TO MOLEX INCORPORATED AND SHOULD NOT BE USED WITHOUT WRITTEN PERMISSION

