

PART NUMBER	ENGINEERING NO.	LENGTH
1300060991	104002A01F030	3' +1.75 - 0 [ 0.9M +44.5 - 0 ]
1300060995	104002A01F060	6' +2.19 - 0 [ 1.8M +55.6 - 0 ]
1300061002	104002A01F120	12' +3.50 - 0 [ 3.7M +88.9 - 0 ]
1300061009	104002A01F200	20' +6.50 - 0 [ 6.1M +165.1 - 0 ]

- NOTES:
1. MATERIAL: SEE TABLE
  2. FINISHES: SEE TABLE
  3. CABLE ASSEMBLIES ARE BAGGED SEPERATELY IN POLY BAGS WITH BARCODE LABEL ATTACHED TO OUTSIDE OF BAG
  4. WRAP LABEL IS MARKED WITH P/N, DATE CODE VOLTAGE & AMPERAGE
  5. MATES WITH: MINI CHANGE, A-SIZE 4 POLE RECEPTACLE
  6. ELECTRICAL SPECIFICATIONS:  
VOLTAGE RATING: 600V  
CURRENT RATING: 10 AMPS
  7. ASSEMBLY IS RoHS COMPLIANT

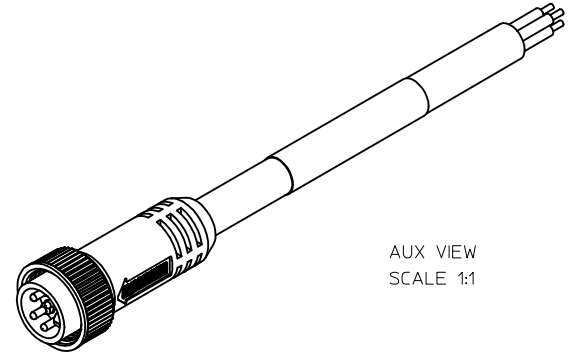

P1

1	BLACK
2	WHITE
3	RED
4	GREEN/YELLOW

WIRING DIAGRAM

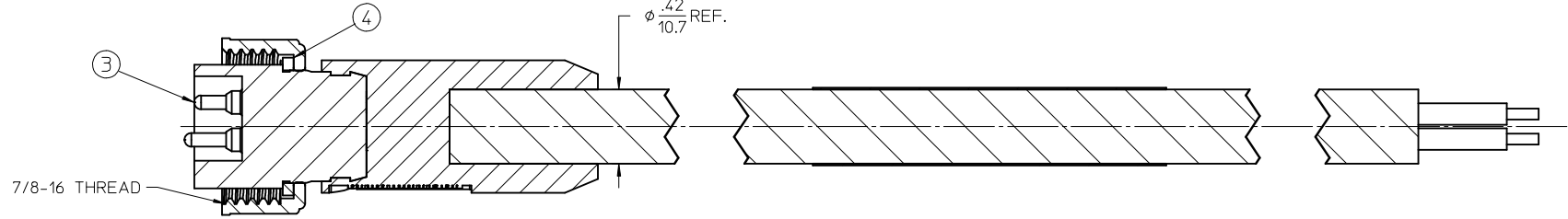

Section Z-Z

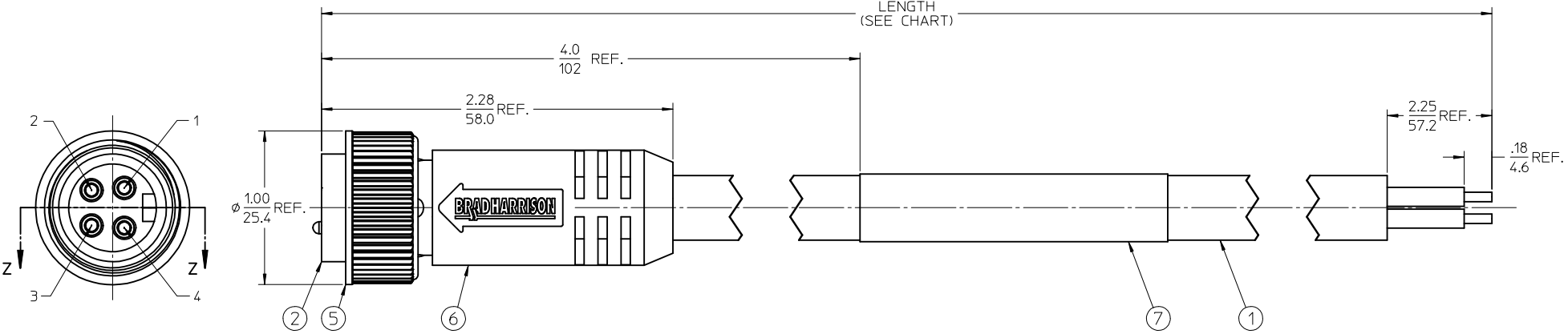

ITEM	QTY.	DESCRIPTION	MATERIAL	FINISH
7	1	LABEL	PLASTIC FILM	BLACK/YELLOW
6	1	OVERMOLD, STRAIGHT	PVC	YELLOW
5	1	COUPLING NUT, FEMALE	ZINC DIE CAST	BLACK
4	1	FRICION RING	NYLON	WHITE
3	4	CONTACT PIN, 16 AWG	BRASS	GOLD PLATED
2	1	INSERT, MALE, 4 POLE	PVC	YELLOW
1	1	CABLE, ST00W/ST #16/4	PVC JACKET	GRAY

PURCHASING DRAWING  
 EC NO: WNA2009-0810  
 DRAWN: LHARTMANN 2009/06/09  
 CHKD: RSTONE  
 APPR: JFMURPHY 2009/06/08

QUALITY SYMBOLS  
 ▽=0  
 ▽=0

GENERAL TOLERANCES (UNLESS SPECIFIED)

	mm	INCH
4 PLACES ±	---	---
3 PLACES ±	---	±.005
2 PLACES ±	---	±.010
1 PLACE ±	---	±.020

ANGULAR ±1/2°

DRAFT WHERE APPLICABLE MUST REMAIN WITHIN DIMENSIONS

DIMENSION STYLE  
 IN/MM

DRAWN BY DATE  
 LHARTMANN 2009/06/05

CHECKED BY DATE  
 RSTONE 2009/06/08

APPROVED BY DATE  
 JFMURPHY 2009/06/08

MATERIAL NO.  
 SEE CHART

SIZE  
 C

SCALE  
 2:1

DESIGN UNITS  
 INCH

THIRD ANGLE PROJECTION

TITLE  
 MINI-CHANGE PORTABLE  
 4 POLE MALE STRAIGHT  
 #16/4 YELLOW ST00W/ST

MOLEX INCORPORATED

DOCUMENT NO.  
 SD-130006-004

SHEET NO.  
 1 OF 1

THIS DRAWING CONTAINS INFORMATION THAT IS PROPRIETARY TO MOLEX INCORPORATED AND SHOULD NOT BE USED WITHOUT WRITTEN PERMISSION