

MATERIAL NO. LOOSE PIECE	ENG. NO.	MATERIAL NO. TAPE MOUNTED	ENG. NO.	STUD SIZE	±.003 *S*	STOCK THICKNESS
191930243	E-360-08	191930244	E-360-08T	8	.173	.050/(1.27) (B)
191930245	E-360-10	191930247	E-360-10T	10	.198	
191930248	E-360-14	191930250	E-360-14T	1/4	.265	
191930251	E-360-56	191930253	E-360-56T	5/16	.328	

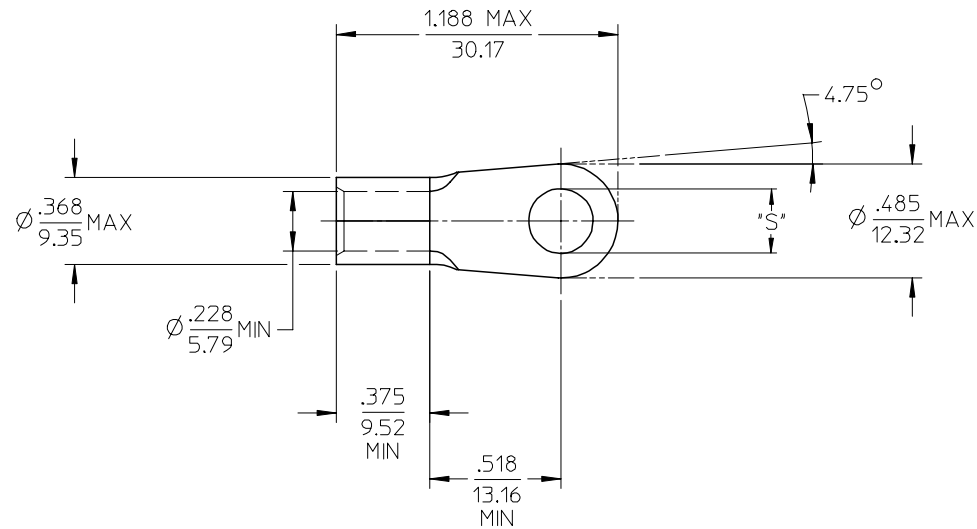
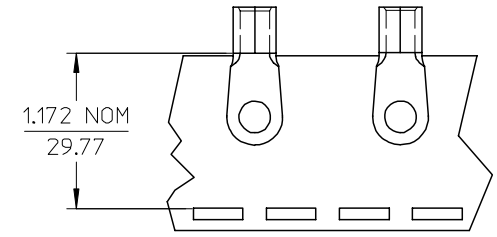

SALES DRAWING

NOTE(S):

1. MATERIAL: COPPER
2. PLATING: ELECTROPLATE TIN
3. ALL DIMENSIONS IN INCHES/(MM).
4. WIRE SIZE: 6 AWG
16 MM²

(B) 5. PART IS ROHS COMPLIANT.

REVISED MATL THKNS EC NO: ETC2007-0011 DRW: NEHLE 2006/07/12 CHKD: JMACNEIL 2006/07/13 APPR: RDOERSS 2006/07/17	QUALITY SYMBOLS ▽=0 ▽=0	GENERAL TOLERANCES (UNLESS SPECIFIED)		DIMENSION STYLE IN/MM	SCALE 2:1	DESIGN UNITS INCH	THIRD ANGLE PROJECTION		
			mm	INCH	DRAWN BY DLM	DATE 03/07/28	TITLE RING TONGUE TERMINAL VERSAKRIMP SERIES 6 AWG		
		4 PLACES	± ---	± ---	CHECKED BY HEB	DATE 03/07/28	APPROVED BY RWD		
		3 PLACES	± ---	± .005	DATE 03/07/28	MATERIAL NO. SEE CHART			
2 PLACES	± 0.13	± .01	APPROVED BY RWD		DATE 03/07/28	DOCUMENT NO. SD-19193-032			
1 PLACE	± 0.25	± ---	ANGULAR ±1/2°		SHEET NO. 1 OF 1				
DRAFT WHERE APPLICABLE MUST REMAIN WITHIN DIMENSIONS				THIS DRAWING CONTAINS INFORMATION THAT IS PROPRIETARY TO MOLEX INCORPORATED AND SHOULD NOT BE USED WITHOUT WRITTEN PERMISSION					