

注記 NOTES

1. 使用材料 MATERIAL
 ウエハー:液晶ポリマー ガラス充填 UL94V-0 黒色
 WAFER:LIQUID CRYSTAL POLYMER, GLASS FILLED,
 UL94V-0, COLOR BLACK
 ピン:リン青銅 (t=0.15)
 PIN:PHOSPHOR BRONZE(t=0.15)
 補強金具:リン青銅 (t=0.2)
 FITTING NAIL:PHOSPHOR BRONZE(t=0.2)
2. メッキ仕様 PLATING
 ピン PIN
 金メッキ
 (コンタクト部とテール部)
 GOLD PLATING
 (CONTACT AND TAIL AREA)
 下地メッキ:ニッケルメッキ 1.5μm 以上
 UNDER PLATING : NICKEL 1.5 MICROMETER MINIMUM.
 補強金具 FITTING NAIL
 錫メッキ 1.0μm 以上
 TIN PLATING 1.0 MICROMETER MINIMUM.
 下地メッキ:ニッケルメッキ 1.0μm 以上
 UNDER PLATING : NICKEL 1.0 MICROMETER MINIMUM.
- △ テール部に適用。
 APPLY TO THE TAIL AREA.
4. 嵌合相手:54552 シリーズ
 MATE WITH : 54552 SERIES.
5. テール平坦度は、0.08 以下
 テール及び金具の平坦度は、0.1 以下
 TAIL COPLANARITY TO BE 0.08MAXIMUM
 TAIL AND FITTING NAIL COPLANARITY TO BE 0.1 MAXIMUM
6. ELV 及び RoHS 適合品
 ELV AND RoHS COMPLIANT
7. 本製品は503376-**19のボス無し品である。
 THIS PRODUCT IS NON-BOSS VERSION OF 503376-**19.

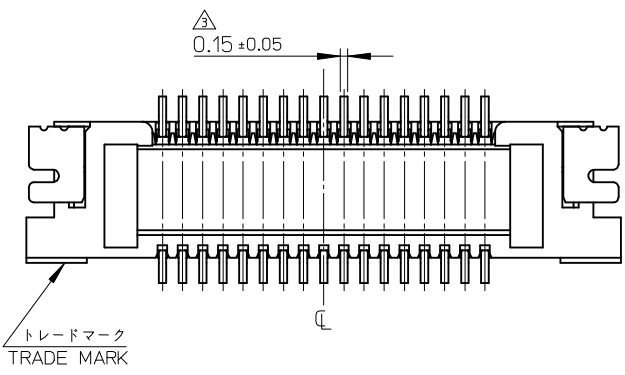
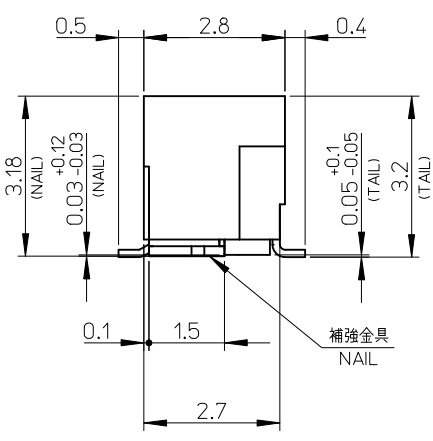
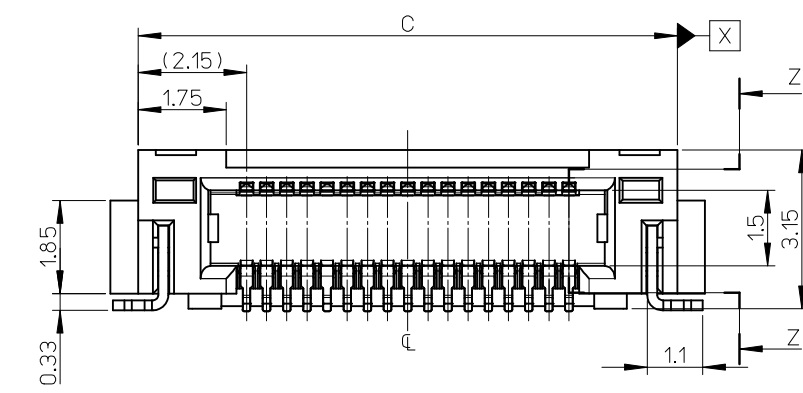
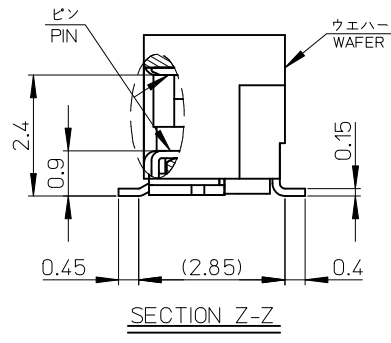
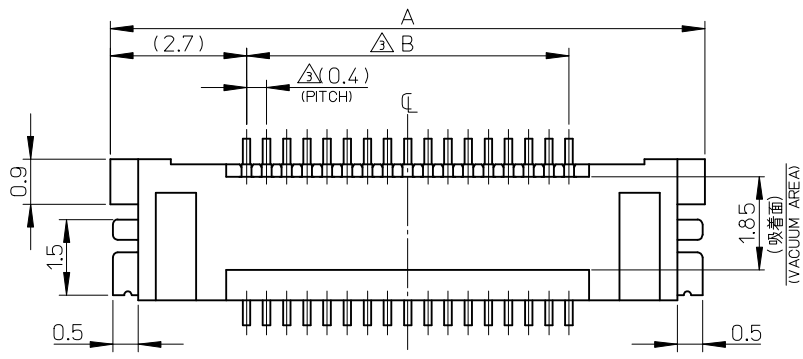

12.5	13.9	9.6	15	503376-5020	50
D	C	B	A	EMBOSSED TAPE PKG.	極数
				ORDER No. オーダー番号	CIRCUITS

CONNECTOR SERIES No. : 503376-**29

RELEASED EC NO: J2013-0242 DRWG:GMATSUNO 2012/08/31 CHKD:TASAKAWA 2012/08/31 APPR:TASAKAWA 2012/08/31	GENERAL TOLERANCES (UNLESS SPECIFIED)		DIMENSION STYLE	SCALE	DESIGN UNITS	THIRD ANGLE PROJECTION
			MM ONLY	---	METRIC	
	DESCRIPTION	10 UNDER	±0.2	DRAWN BY	DATE	TITLE
		10 OVER 30 UNDER	±0.25	GMATSUNO	2012/08/27	0.4 B-TO-B CONN. RA PLUG NAIL ASSY (WITHOUT BOSS)
		30 OVER	±0.3	TASAKAWA	2012/08/27	
	ANGULAR	±3 °	APPROVED BY	DATE	molex	
	DRAFT WHERE APPLICABLE	MUST REMAIN WITHIN DIMENSIONS	TASAKAWA	2012/08/31		
			MATERIAL NO.	DOCUMENT NO.	SHEET NO.	
			SEE CHART	SD-503376-003	1 OF 2	
			SIZE A3	THIS DRAWING CONTAINS INFORMATION THAT IS PROPRIETARY TO MOLEX INCORPORATED AND SHOULD NOT BE USED WITHOUT WRITTEN PERMISSION		

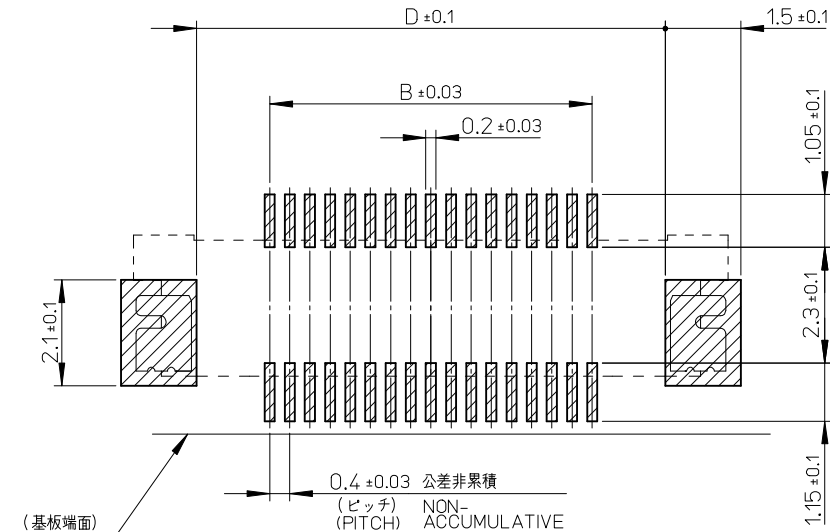

(基板端面)
(PWB EDGE)

推奨基板レイアウト(マウント面)

RECOMMENDED P.W.BOARD
PATTERN DIMENSION. (REFERENCE)
(MOUNTING AREA)

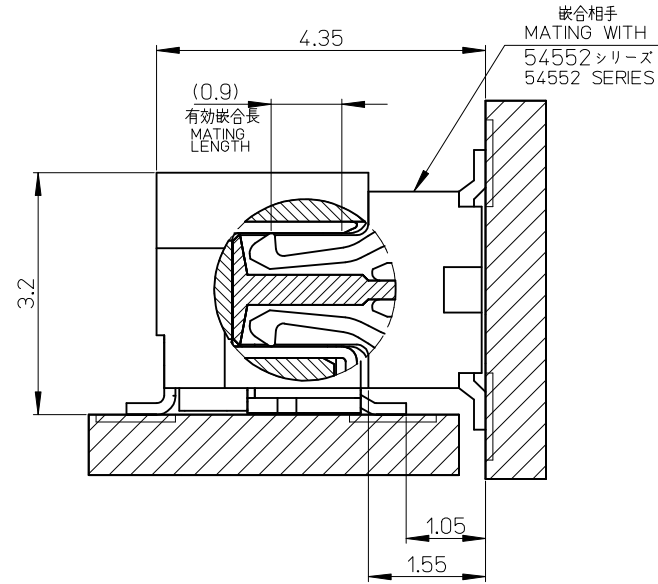

嵌合断面 (参考)

MATED DRAWING(REFERENCE)

RELEASED EC NO: J2013-0242 DRWG: GMATSUNO 2012/08/31 CHKD: TASAKAWA 2012/08/31 APPR: TASAKAWA 2012/08/31	DESCRIPTION REV: 0	GENERAL TOLERANCES (UNLESS SPECIFIED)		DIMENSION STYLE MM ONLY		CONNECTOR SERIES No.	503376-**29			
		10 UNDER	± 0.2	DRAWN BY	DATE	SCALE	DESIGN UNITS	THIRD ANGLE PROJECTION		
		10 OVER 30 UNDER	± 0.25	TASAKAWA	2012/08/27	---	METRIC	TITLE 0.4 B-TO-B CONN. RA PLUG NAIL ASSY (WITHOUT BOSS)		
		30 OVER	± 0.3	TASAKAWA	2012/08/27	SEE CHART				
		ANGULAR ± 3 °		DRAFT WHERE APPLICABLE MUST REMAIN WITHIN DIMENSIONS		MATERIAL NO.	DOCUMENT NO.	SHEET NO.		
				SIZE A3	THIS DRAWING CONTAINS INFORMATION THAT IS PROPRIETARY TO MOLEX INCORPORATED AND SHOULD NOT BE USED WITHOUT WRITTEN PERMISSION					

NOTES

- 製品詳細寸法については SD-503376-003 を参照ください。
RE DETAILED DIMENSION, SEE SD-503376-003
- 梱包数量：1500個/リール
NUMBER OF CONNECTORS : 1500PCS/REEL
- リードテープ長さ LEAD TAPE LENGTH

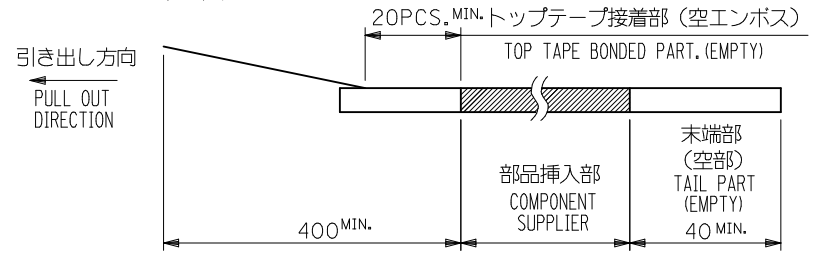
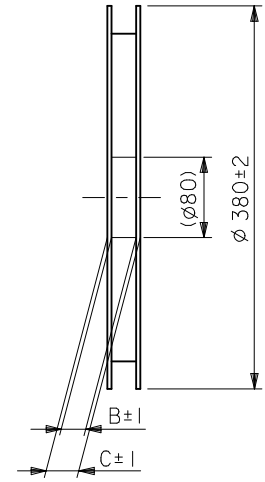
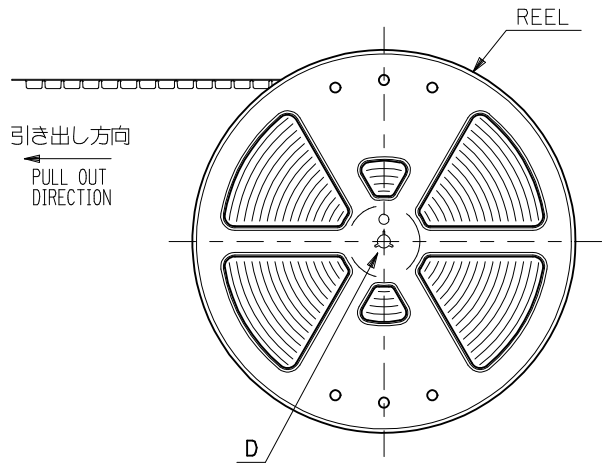

- トップテープの剥離強度：0.1 ~ 1.3N {10 ~ 130gf} (剥離方向は下図参照)
尚、本規格値は出荷時に適用。(但し、輸送時に剥離が発生しないこと。)
PEELING OFF FORCE OF TOP TAPE : 0.1 ~ 1.3N {10 ~ 130gf}
(PEELING DIRECTION AS SHOWN IN FOLLOWING FIG.)
THIS REQUIREMENT SHOULD BE APPLIED AT SHIPMENT.
PEEL OFF SHOULD NOT BE ALLOWED , DURING TRANSPORTATION.

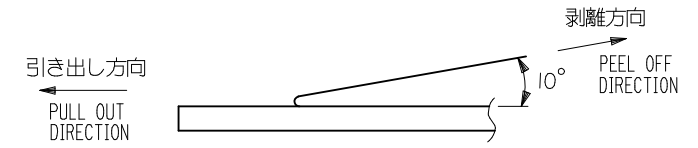

- 材料 (MATERIAL)
キャリアテープ (CARRIER TAPE) : ポリプロピレン (POLYPROPYLENE)
トップテープ (TOPTAPE) : PET , PE , PEF
リール (REEL) : ポリスチレン (P S) (リサイクル材を含む)
POLYSTYRENE (PS) <RECYCLE MATERIAL CONTAINED>

- ELV 及び RoHS適合品
ELV AND RoHS COMPLIANT.

- 本製品は、503376-**10 のボス無し品である。
THIS PRODUCT IS NON-BOSS VERSION OF 503376-**10.

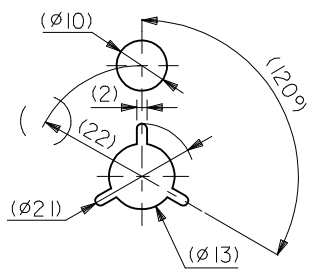

DETAIL D

503376-5020	50
EMBOSSED TAPE PKG.	極数
ORDER No. オーダー番号	CIRCUITS

CONNECTOR SERIES NO. 503376-**20

RELEASED EC NO.: J2013-0242 DRWG: GMATSUNO 2012/08/31 CHKD: TASAKAWA 2012/08/31 APPR: TASAKAWA 2012/08/31	GENERAL TOLERANCES (UNLESS SPECIFIED)		DIMENSION STYLE MM ONLY		SCALE ---	DESIGN UNITS METRIC	THIRD ANGLE PROJECTION
	10 UNDER	±0.2	DRAWN BY GMATSUNO	DATE 2012/08/27	TITLE EMBSTP PKG FOR 0.4 B/B CONN. RA PLUG NAIL ASSY WITHOUT BOSS molex DOCUMENT NO. SD-503376-004 SHEET NO. 1 OF 2		
	10 OVER 30 UNDER	±0.25	CHECKED BY TASAKAWA	DATE 2012/08/27			
	30 OVER	±0.3	APPROVED BY TASAKAWA	DATE 2012/08/31			
	ANGULAR ±3 °		MATERIAL NO. SEE CHART				
DRAFT WHERE APPLICABLE MUST REMAIN WITHIN DIMENSIONS		SIZE A3					
0	REV	THIS DRAWING CONTAINS INFORMATION THAT IS PROPRIETARY TO MOLEX INCORPORATED AND SHOULD NOT BE USED WITHOUT WRITTEN PERMISSION					

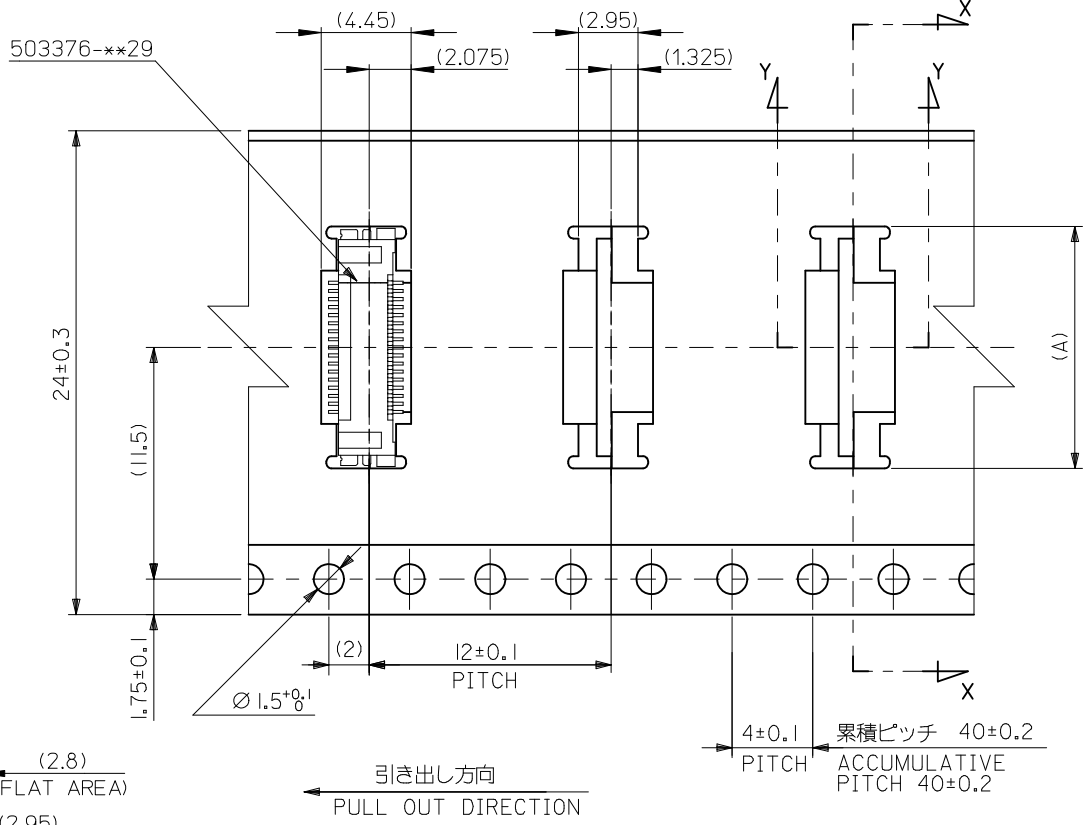
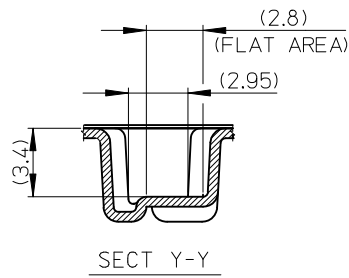
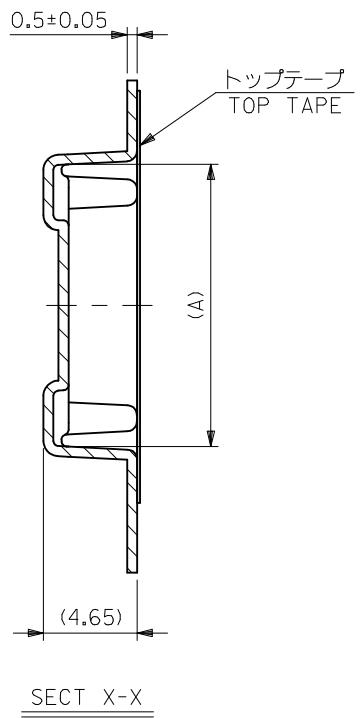

24mm幅キャリアテープ
24mm WIDTH CARRIER TAPE

24	29.4	25.4	15.2	503376-5020	50
キャリアテープ幅 CARRIER TAPE WIDTH	C	B	(A)	EMBOSSED TAPE PKG. ORDER No. オーダー番号	極数 CIRCUITS

RELEASED EC NO: J2013-0242 DRWG: GMATSUNO 2012/08/31 CHKD: TASAKAWA 2012/08/31 APPR: TASAKAWA 2012/08/31	GENERAL TOLERANCES (UNLESS SPECIFIED)		DIMENSION STYLE MM ONLY		SCALE ---	MODEL NO. 503376-**20
	10 UNDER	±0.2	DRAWN BY GMATSUNO	DATE 2012/08/27	TITLE EMBSTP PKG FOR 0.4 B/B CONN. RA PLUG NAIL ASSY WITHOUT BOSS	
	10 OVER 30 UNDER	±0.25	CHECKED BY TASAKAWA	DATE 2012/08/27	molex DOCUMENT NO. SD-503376-004 SHEET NO. 2 OF 2	
	30 OVER	±0.3	APPROVED BY TASAKAWA	DATE 2012/08/31		
0	DESCRIPTION ANGULAR ±3 ° DRAFT WHERE APPLICABLE MUST REMAIN WITHIN DIMENSIONS	MATERIAL NO. SEE CHART		THIS DRAWING CONTAINS INFORMATION THAT IS PROPRIETARY TO MOLEX INCORPORATED AND SHOULD NOT BE USED WITHOUT WRITTEN PERMISSION		