

| LOOSE PIECE     |                    | TAPE MOUNTED    |                    | DIMENSIONS |           |          |          |           |           |            |            |         | FINISH           |
|-----------------|--------------------|-----------------|--------------------|------------|-----------|----------|----------|-----------|-----------|------------|------------|---------|------------------|
| MATERIAL NUMBER | ENGINEERING NUMBER | MATERIAL NUMBER | ENGINEERING NUMBER | STUD SIZE  | S ±.005   | W MAX    | C MIN    | ID MIN    | MWID      | B REF      | L MAX      | H REF   | INSULATION COLOR |
| 191190004       | A-215-06X          | 191190005       | A-215-06XT         | 6          | .146/3.71 | .301/7.6 | .207/5.3 | .054/1.37 | .145/3.68 | .450/11.43 | .836/21.23 | .08/2.0 | RED              |
| 191190007       | A-215-08X          | 191190008       | A-215-08XT         | 8          | .173/4.39 | .301/7.6 | .207/5.3 | .054/1.37 | .145/3.68 | .450/11.43 | .836/21.23 | .08/2.0 | RED              |
| 191190010       | A-215-10X          | 191190051       | A-215-10XT         | 10         | .198/5.03 | .301/7.6 | .207/5.3 | .054/1.37 | .145/3.68 | .450/11.43 | .836/21.23 | .08/2.0 | RED              |
| 191190080       | B-216-06X          | 191190027       | B-216-06XT         | 6          | .146/3.71 | .301/7.6 | .209/5.3 | .081/2.06 | .175/4.45 | .450/11.43 | .850/21.59 | .08/2.0 | BLUE             |
| 191190029       | B-216-08X          | 191190030       | B-216-08XT         | 8          | .173/4.39 | .301/7.6 | .209/5.3 | .081/2.06 | .175/4.45 | .450/11.43 | .850/21.59 | .08/2.0 | BLUE             |
| 191190032       | B-216-10X          | 191190033       | B-216-10XT         | 10         | .198/5.03 | .301/7.6 | .209/5.3 | .081/2.06 | .175/4.45 | .450/11.43 | .850/21.59 | .08/2.0 | BLUE             |

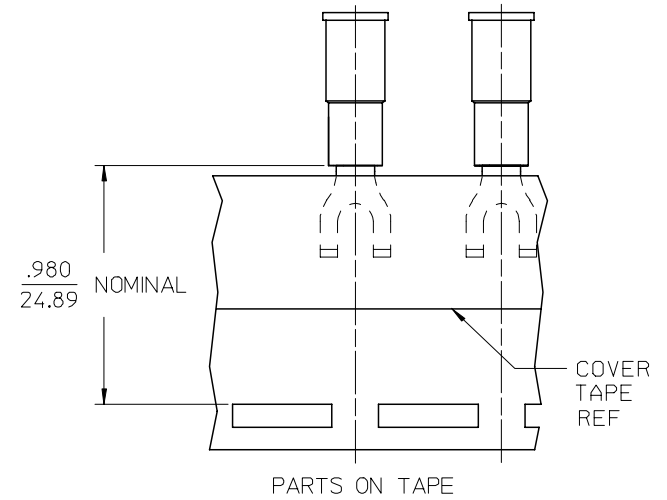
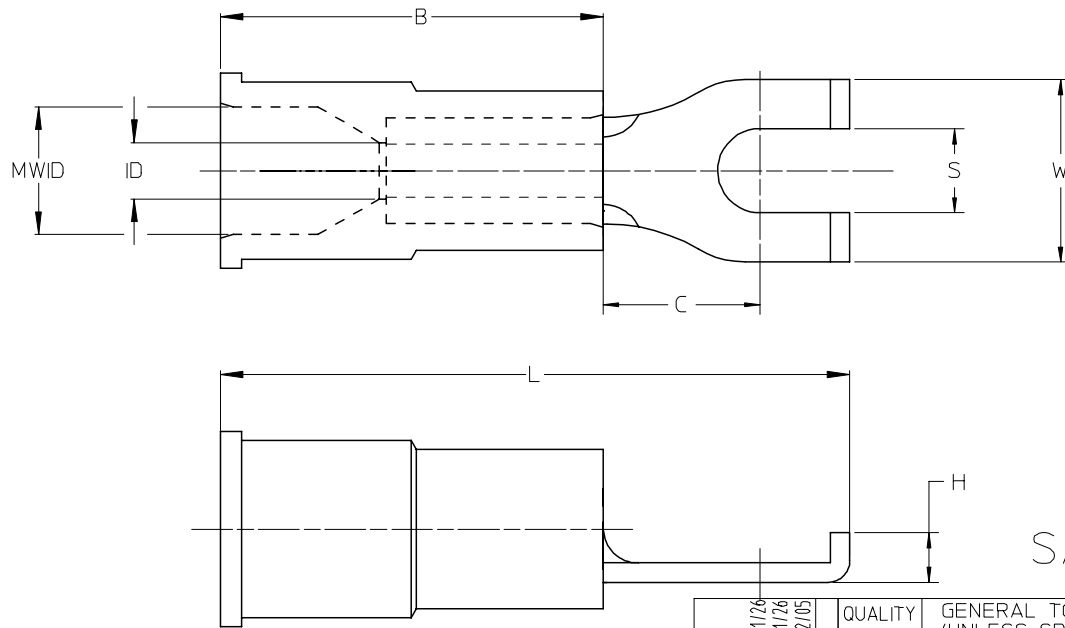

SALES DRAWING

- NOTES:
1. MATERIAL: COPPER .031/.79 THICK
  2. PLATING: ELECTRO-TIN
  3. MWID = MAXIMUM WIRE INSULATION DIAMETER
  4. PART IS RoHS COMPLIANT

|   |                       |                                       |                 |       |                           |   |
|---|-----------------------|---------------------------------------|-----------------|-------|---------------------------|---|
| STANDARDIZE<br>EC NO: ETC2008-0012<br>2007/11/26<br>DRWR:RSTONE<br>CHKD:JMACNEIL<br>APPR:JMACNEIL<br>2007/12/05 | QUALITY SYMBOLS       | GENERAL TOLERANCES (UNLESS SPECIFIED) | DIMENSION STYLE | SCALE | DESIGN UNITS              | THIRD ANGLE PROJECTION  |
|   | ▽=0                   | mm INCH                               | IN/MM           | ---   | INCH                      |   |
|   | ▽=0                   | 4 PLACES ± --- ± ---                  | DRAWN BY DATE   |       |                           | TITLE   |
|   |                       | 3 PLACES ± --- ± .005                 | K0 1984/10/25   |       |                           | FLANGED SPADE TERMINAL,<br>INSULKRIMP -200 SERIES,<br>LONG BARREL |
|   | 2 PLACES ± 0.13 ± .01 | CHECKED BY DATE                       |                 |       |                           |   |
|   | 1 PLACE ± 0.25 ± ---  | GZ 1984/11/09                         |                 |       |                           |   |
|   | ANGULAR ±1/2°         | APPROVED BY DATE                      |                 |       |                           |   |
|   |                       |                                       |                 |       | MATERIAL NO. DOCUMENT NO. |   |
|   |                       |                                       |                 |       | SEE CHART SD-19119-003    |   |
|   |                       |                                       |                 |       |                           | SHEET NO. 1 OF 1  |
|   |                       |                                       |                 |       |                           |   |