

MATERIAL NUMBER	# OF COLUMNS	# OF DIFF PAIR	DIM 'A' MAX	DIM 'B'	PTH ϕ
170469-#8**	8	32	22.80	13.30	0.46+0.05
170469-#1**	10	40	26.60	17.10	0.46+0.05
170469-#6**	16	64	38.00	28.50	0.46+0.05
170469-#8**	8	32	22.80	13.30	0.39+0.05
170469-#1**	10	40	26.60	17.10	0.39+0.05
170469-#6**	16	64	38.00	28.50	0.39+0.05

170469-***

MODULE TYPE
 5 = RIGHT GUIDED, LEAD-FREE
 9 = RIGHT GUIDED, LEAD-FREE W/ ENDWALL

OF COLUMNS
 1 = 10 COLUMNS
 6 = 16 COLUMNS
 8 = 8 COLUMNS

PIN LENGTH (P)
 4 = 4.90 (0.46 PTH)
 5 = 5.50 (0.46 PTH)
 7 = 4.90 (0.39 PTH)
 8 = 5.50 (0.39 PTH)

KEY ORIENTATION
 0 = NO KEY
 1 = A 5 = H
 2 = B 6 = I
 3 = C 7 = G
 4 = D 8 = H

- NOTES:
- MATERIALS: HOUSING - LIQUID CRYSTAL POLYMER (LCP), GLASS-FILLED UL94V-0 TERMINALS - HIGH PERFORMANCE COPPER ALLOY
 - FINISH: 104N SELECTIVE GOLD IN CONTACT AREA, SELECTIVE TIN ON PCB TAILS, NICKEL OVERALL.
 - REFER TO MOLEX PRODUCT SPECIFICATION PS-76060-999 FOR PERFORMANCE SPECIFICATIONS AND ADDITIONAL PCB INFORMATION.
 - EACH SIGNAL WAFER CONTAINS 2 COLUMNS OF TERMINALS.
 - PRODUCT IS PACKAGED PER PK-70873-041.
 - THIS PART CONFORMS TO CLASS B REQUIREMENTS OF COSMETIC SPEC PS-45499-002.
 - REFER TO MOLEX SALES DRAWING SD-172103-0002 FOR THE MATING RECEPTACLES.
 - REFER TO MOLEX PCB ROUTING GUIDE AS-76060-990 FOR ANTIPAD AND ROUTING RECOMMENDATIONS.
 - CONNECTORS SUPPLIED WITH A 2-32 THREAD FORMING MOUNTING SCREW.
 - GUIDE RIGHT RAM MATES WITH A GUIDE LEFT DAUGHTERCARD.

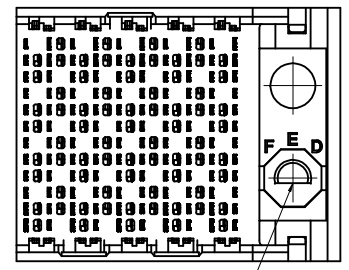
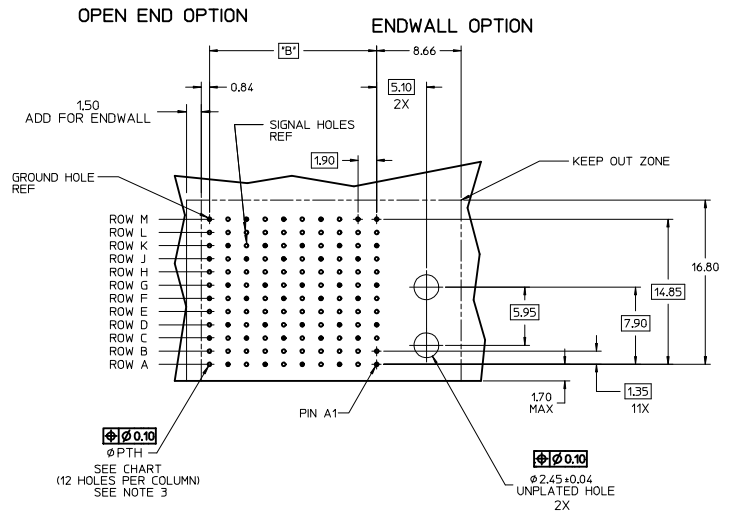
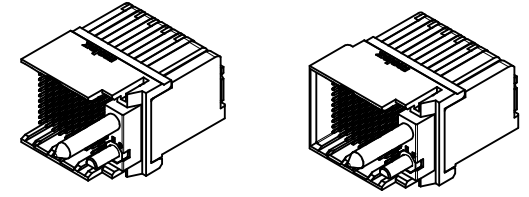
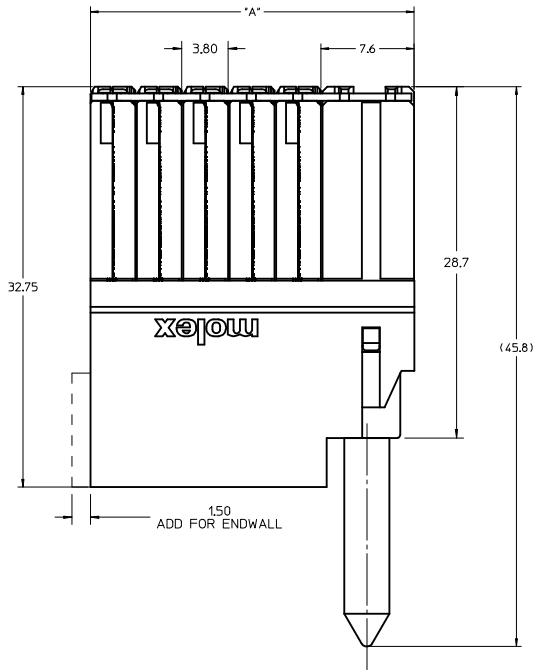
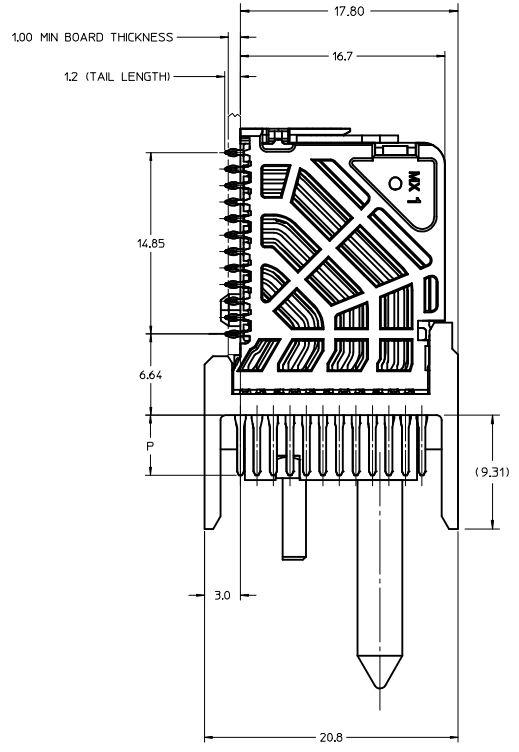

KEY SHOWN IN POSITION A

RAM HOLE PATTERN (CONNECTOR SIDE)

UPD DRAWING/PCB LAYOUT EEC NO: UCP2014-4979 DRWNS:GONZALEZ01_2014/06/18 CHKD: APPR:TELO	2015/01/20	QUALITY SYMBOLS	GENERAL TOLERANCES (UNLESS SPECIFIED)	DIMENSION STYLE	SCALE	DESIGN UNITS	THIRD ANGLE PROJECTION
		▽=0	mm	MM ONLY	5:1	METRIC	
		▽=0	INCH				
		▽=0					
			4 PLACES +--- +---	DRAWN BY	DATE	TITLE	
			3 PLACES +--- +---	DVARVARA	2013/07/02	IMPACT 4-PAIR 100-OHM	
			2 PLACES +0.13 +---	CHECKED BY	DATE	GUIDE RIGHT RAM SIGNAL	
			1 PLACE +0.25 +---	TELO	2013/07/02	MODULE SALES DWG, MAPS	
			0 PLACE +--- +---	APPROVED BY	DATE	molex	
			ANGULAR ±1/2°	TELO	2013/10/18	SD-170469-0004	
			DRAFT WHERE APPLICABLE MUST REMAIN WITHIN DIMENSIONS	MATERIAL NO.	DOCUMENT NO.	SHEET NO.	
				SEE TABLE		1 OF 2	
				THIS DRAWING CONTAINS INFORMATION THAT IS PROPRIETARY TO MOLEX INCORPORATED AND SHOULD NOT BE USED WITHOUT WRITTEN PERMISSION			

20 19 18 17 16 15 14 13 12 11 10 9 8 7 6 5 4 3 2 1

M
L
K
J
I
H
G
F
E
D
C
B
A

COPLANAR APPLICATION

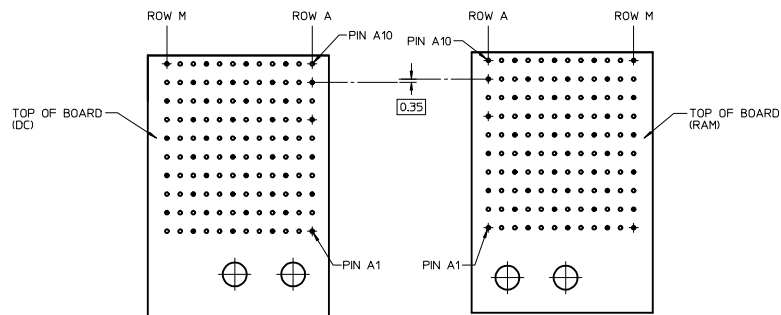
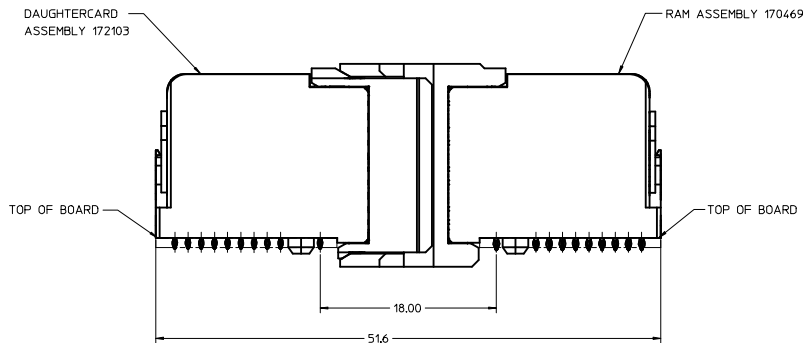

COPLANAR MATED SIGNAL PATHS

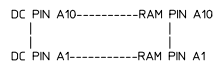

<p>SEE SHEET 1 EC NO. UCP2014-4979 DRAWN: GONZALEZ01 2014/06/18 CHKD: APPR:TELO 2015/01/30 REV DESCRIPTION</p>	QUALITY SYMBOLS	GENERAL TOLERANCES (UNLESS SPECIFIED)	DIMENSION STYLE	SCALE	DESIGN UNITS	THIRD ANGLE PROJECTION
	▽=0	mm INCH	MM ONLY	4:1	METRIC	
	▽=0	4 PLACES ± --- ± ---	DRAWN BY DATE	<p>TITLE IMPACT 4-PAIR 100-OHM GUIDE RIGHT RAM SIGNAL MODULE SALES DWG, MAPS</p> <p>molex</p> <p>MATERIAL NO. SEE TABLE DOCUMENT NO. SD-170469-0004 SHEET NO. 2 OF 2</p>		
	▽=0	3 PLACES ± --- ± ---	CHECKED BY DATE			
▽=0	2 PLACES ± 0.13 ± ---	TELO 2013/07/02				
	1 PLACE ± 0.25 ± ---	APPROVED BY DATE				
	0 PLACE ± --- ± ---	TELO 2013/10/18	<p>ANGULAR ±1/2° DRAFT WHERE APPLICABLE MUST REMAIN WITHIN DIMENSIONS</p>			

19 18 17 16 15 14 13 12 11 10 9 8 7 6 5 4 3 2 1

MATERIAL NUMBER	# OF COLUMNS	# OF DIFF PAIR	DIM 'A' MAX	DIM 'B'	PTH ϕ
76500-#8**	8	32	22.80	13.30	0.46±0.05
76500-#1**	10	40	26.60	17.10	0.46±0.05
76500-#6**	16	64	38.00	28.50	0.46±0.05
76500-#8**	8	32	22.80	13.30	0.39±0.05
76500-#1**	10	40	26.60	17.10	0.39±0.05
76500-#6**	16	64	38.00	28.50	0.39±0.05

76500-***

MODULE TYPE
 5 = RIGHT GUIDED, LEAD-FREE
 9 = RIGHT GUIDED, LEAD-FREE W/ ENDWALL

PIN LENGTH (P)
 4 = 4.90 (0.46 PTH)
 5 = 5.50 (0.46 PTH)
 7 = 4.90 (0.39 PTH)
 8 = 5.50 (0.39 PTH)

OF COLUMNS
 1 = 10 COLUMNS
 6 = 16 COLUMNS
 8 = 8 COLUMNS

KEY ORIENTATION
 0 = NO KEY
 1 = A 5 = E
 2 = B 6 = F
 3 = C 7 = G
 4 = D 8 = H

- NOTES:
- MATERIALS: HOUSING - LIQUID CRYSTAL POLYMER (LCP), GLASS-FILLED, UL94V-0
TERMINALS - HIGH PERFORMANCE COPPER ALLOY
 - FINISH: 30MN SELECTIVE GOLD IN CONTACT AREA, SELECTIVE TIN ON PCB TAILS, NICKEL OVERALL.
 - REFER TO MOLEX PRODUCT SPECIFICATION PS-76060-999 FOR PERFORMANCE SPECIFICATIONS AND ADDITIONAL PCB INFORMATION.
 - EACH SIGNAL WAFER CONTAINS 2 COLUMNS OF TERMINALS.
 - PRODUCT IS PACKAGED PER PK-70873-041.
 - THIS PART CONFORMS TO CLASS B REQUIREMENTS OF COSMETIC SPEC PS-45499-002.
 - REFER TO MOLEX SALES DRAWING SD-76160-002 FOR THE MATING RECEPTACLES.
 - REFER TO MOLEX PCB ROUTING GUIDE AS-76060-990 FOR ANTIPAD AND ROUTING RECOMMENDATIONS.
 - WHEN USING MOLEX SUPPLIED #2-32 SCREW 73726-0000 (9.50mm ±0.38mm THREADABLE SCREW LENGTH), THE MAXIMUM BOARD THICKNESS IS 4.4mm.
 - GUIDE RIGHT RAM MATES WITH A GUIDE LEFT DAUGHTERCARD.

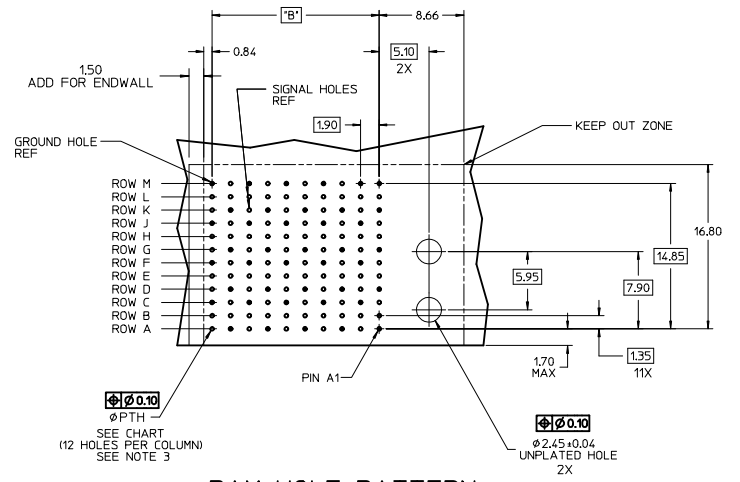
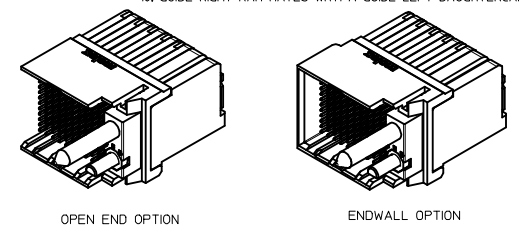
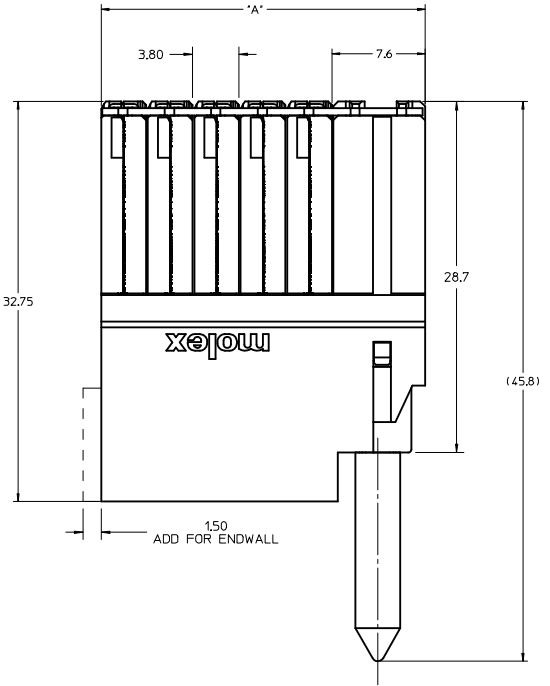
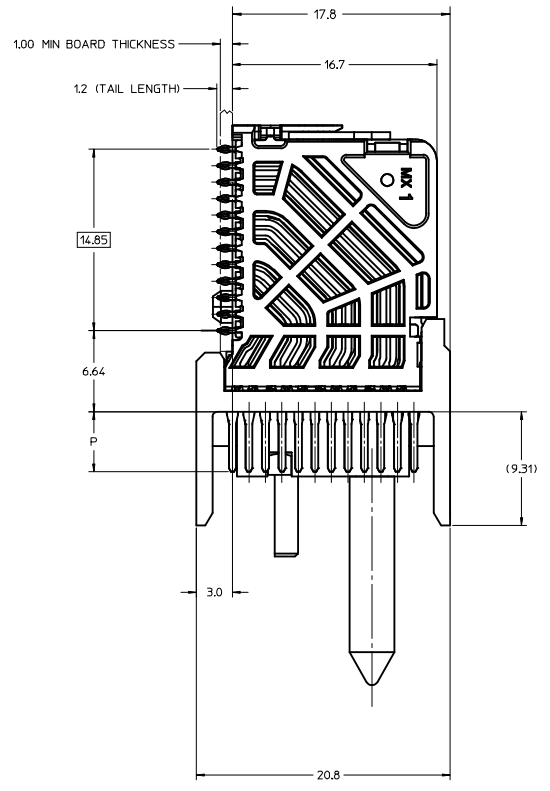

RAM HOLE PATTERN (CONNECTOR SIDE)

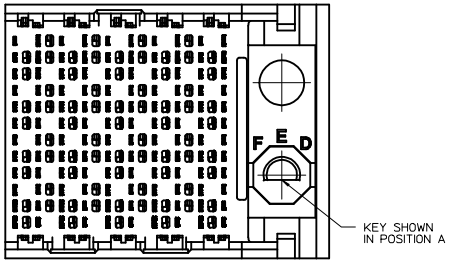

UPD DRAWING/PCB LAYOUT EEC NO: UCP2014-4979 DRAWN: GONZALEZ01 2014/05/28 CHKD: APPR: ELO	QUALITY SYMBOLS	GENERAL TOLERANCES (UNLESS SPECIFIED)	DIMENSION STYLE	SCALE	DESIGN UNITS	THIRD ANGLE PROJECTION
	▽=0	mm INCH	MM ONLY	5:1	METRIC	◎
	▽=0	4 PLACES ±0.13				
	▽=0	2 PLACES ±0.25				
		ANGULAR ±1/2°				
		DRAFT WHERE APPLICABLE MUST REMAIN WITHIN DIMENSIONS				
			SIZE D			

DRAWN BY: JOUILLES CHECKED BY: JLAURX APPROVED BY: JLAURX DATE: 2008/12/10 DATE: 2008/12/11 DATE: 2008/12/12	TITLE: IMPACT 4 PAIR RAM GUIDE RIGHT SIGNAL MODULE SALES DWG molex	MATERIAL NO: SD-76500-004	DOCUMENT NO: SD-76500-004	SHEET NO: 1 OF 2
---	--	-------------------------------------	-------------------------------------	----------------------------

20 19 18 17 16 15 14 13 12 11 10 9 8 7 6 5 4 3 2 1

COPLANAR APPLICATION

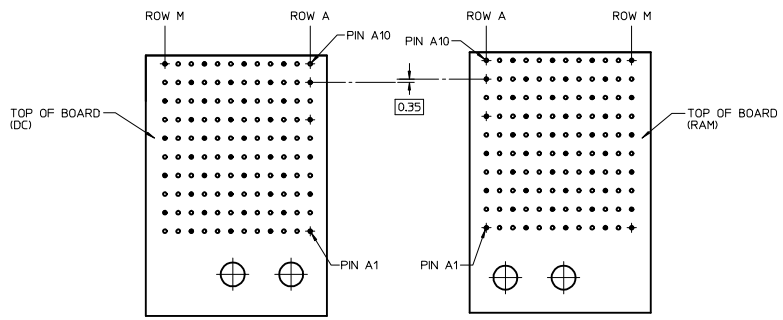
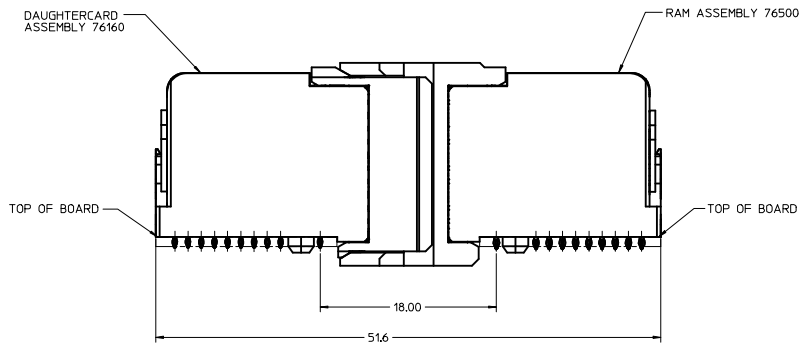

COPLANAR MATED SIGNAL PATHS

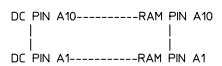

SEE SHEET 1 DEC NO. UCP2014-4979 DRAWN: GONZALEZ01 2014/05/28 CHKD: APPR: TEL0 REV:	QUALITY SYMBOLS	GENERAL TOLERANCES (UNLESS SPECIFIED)	DIMENSION STYLE	SCALE	DESIGN UNITS	THIRD ANGLE PROJECTION
	▽=0	mm INCH	MM ONLY	4:1	METRIC	☉
	▽=0	4 PLACES ± --- ± ---	DRAWN BY	DATE	TITLE	
	▽=0	3 PLACES ± --- ± ---	JOUILES	2008/12/10	IMPACT 4 PAIR RAM	
	2 PLACES ± 0.13 ± ---	CHECKED BY	DATE			
	1 PLACE ± 0.25 ± ---	JLAURX	2008/12/11			
	0 PLACE ± --- ± ---	APPROVED BY	DATE			
		JLAURX	2008/12/12			
	ANGULAR ±1/2°	MATERIAL NO.	SEE TABLE	DOCUMENT NO.		
	DRAFT WHERE APPLICABLE MUST REMAIN WITHIN DIMENSIONS	SD-76500-004				

THIS DRAWING CONTAINS INFORMATION THAT IS PROPRIETARY TO MOLEX INCORPORATED AND SHOULD NOT BE USED WITHOUT WRITTEN PERMISSION

19 18 17 16 15 14 13 12 11 10 9 8 7 6 5 4 3 2 1