

NOTES:
 SNAP FEATURES
 2 CKT 2 SNAPS
 3-24 CKT 3 SNAPS
 LOCATED ON ENDS AND
 ALIGNED WITH SCREWDRIIVER
 REMOVAL SLOT

WINDOW ON PLUG
 ALIGNS WITH SNAP
 ON HEADER ALWAYS
 CENTERED ON PART
 OR ONE CIRCUIT TO
 THE LEFT OF CENTER

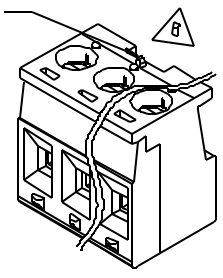

AUXILIARY VIEW
 SCALE 2:1

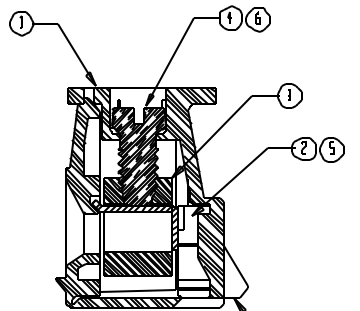

SECTION Z-Z
 ALIGNMENT FEATURE

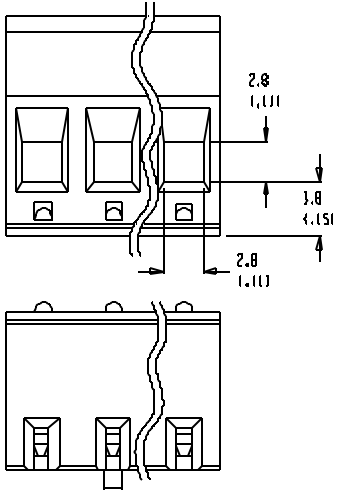
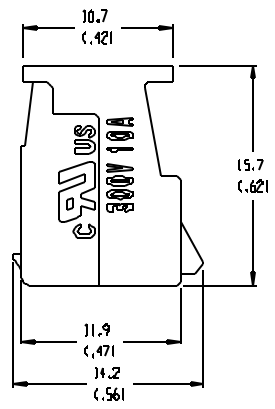

- NOTES:
1. MATERIAL: SEE TABLE
 2. FINISHES: SEE TABLE
 3. PRODUCT SPECIFICATION: NOT REQUIRED
 4. PACKAGING: NOT REQUIRED
 5. MATES WITH: 98 SERIES HEADERS.

MATERIAL NO. (OPT. -G30)	MATERIAL NO. STANDARD	NUMBER OF CIRCUITS "XX"	DIM. "A"	DIM. "B"	DIM. "C"
399810302	399800302	02	10.92 (1.430)	5.08 (1.200)	5.08 (1.200)
399810303	399800303	03	16.00 (1.630)	10.16 (1.400)	10.16 (1.400)
399810304	399800304	04	21.08 (1.830)	15.24 (1.600)	10.16 (1.400)
399810305	399800305	05	26.16 (1.030)	20.34 (1.600)	10.16 (1.400)
399810306	399800306	06	31.24 (1.230)	25.40 (1.000)	15.24 (1.600)
399810307	399800307	07	36.32 (1.430)	30.48 (1.200)	15.24 (1.600)
399810308	399800308	08	41.40 (1.630)	35.56 (1.400)	20.34 (1.800)
399810309	399800309	09	46.48 (1.830)	40.64 (1.600)	20.34 (1.800)
399810310	399800310	10	51.56 (2.030)	45.72 (1.800)	25.40 (1.000)
399810311	399800311	11	56.64 (2.230)	50.80 (2.000)	25.40 (1.000)
399810312	399800312	12	61.72 (2.430)	55.88 (2.200)	30.48 (1.200)
399810313	399800313	13	66.80 (2.630)	60.96 (2.400)	30.48 (1.200)
399810314	399800314	14	71.88 (2.830)	66.04 (2.600)	35.56 (1.400)
399810315	399800315	15	76.96 (3.030)	71.12 (2.800)	35.56 (1.400)
399810316	399800316	16	82.04 (3.230)	76.20 (3.000)	40.64 (1.600)
399810317	399800317	17	87.12 (3.430)	81.28 (3.200)	40.64 (1.600)
399810318	399800318	18	92.20 (3.630)	86.36 (3.400)	45.72 (1.800)
399810319	399800319	19	97.28 (3.830)	91.44 (3.600)	45.72 (1.800)
399810320	399800320	20	102.36 (4.030)	96.52 (3.800)	50.80 (2.000)
399810321	399800321	21	107.44 (4.230)	101.60 (4.000)	50.80 (2.000)
399810322	399800322	22	112.52 (4.430)	106.68 (4.200)	55.88 (2.200)
399810323	399800323	23	117.60 (4.630)	111.76 (4.400)	55.88 (2.200)
399810324	399800324	24	122.68 (4.830)	116.84 (4.600)	60.96 (2.400)

ITEM	QTY.	DESCRIPTION	MATERIAL	FINISH
6	XX	SCREW, M3 X 0.5, SLOTTED (1-G30 OPTION)	PHOS. BRONZE	TIN
5	XX	TERMINAL (1-G30 OPTION)	PHOS. BRONZE	GOLD
4	XX	SCREW, M3 X 0.5, SLOTTED	STEEL	ZN, CLEAR CHROMATE
3	XX	RISING CAGE	BRASS	NICKEL
2	XX	TERMINAL	PHOS. BRONZE	TIN
1	1	INSULATOR	NYLON	BLACK

EC NO. 11499
 DRW. RK 3-31-04
 CHK. APPR.

DESCRIPTION

MAJOR

CRITICAL

SPEC

REV

GENERAL TOLERANCES (UNLESS SPECIFIED)

	MM	INCH
4 PLACES	±.0015	
3 PLACES	±.038	±.005
2 PLACES	±.13	±.01
1 PLACE	±.3	
ANGULAR	±2°	

DRAFT WHERE APPLICABLE MUST REMAIN WITHIN DIMENSIONS

SCALE 3:1

DESIGN UNITS MM INCH

THIRD ANGLE PROJECTION THIRD ANGLE FIRST ANGLE

DRAWN BY & DATE
 R. KEMP 3-27-02

CHECKED BY & DATE
 AMP 3-27-02

APPROVED BY & DATE
 P. WALTZ 3-27-02

CAD FILENAME
 9809XX

PROJECT NO. 1

DIMENSIONS: MM INCH BOTH ONLY

SHT REV

REVISE ON CAD ONLY

TITLE:
 SR EUROSTYLE PLUG, ASSEMBLY
 5.08 (1.200)

MATERIAL NO. SEE CHART

DRAWING NO. SD-39980-010

SHEET NO. 1 OF 1

THIS DRAWING CONTAINS INFORMATION THAT IS PROPRIETARY TO MOLEX INCORPORATED AND SHOULD NOT BE USED WITHOUT WRITTEN PERMISSION.

Ⓐ REF. THIS DRAWING IS SUPERSEDED CADKEY DOC SD-39980-010 REV-B

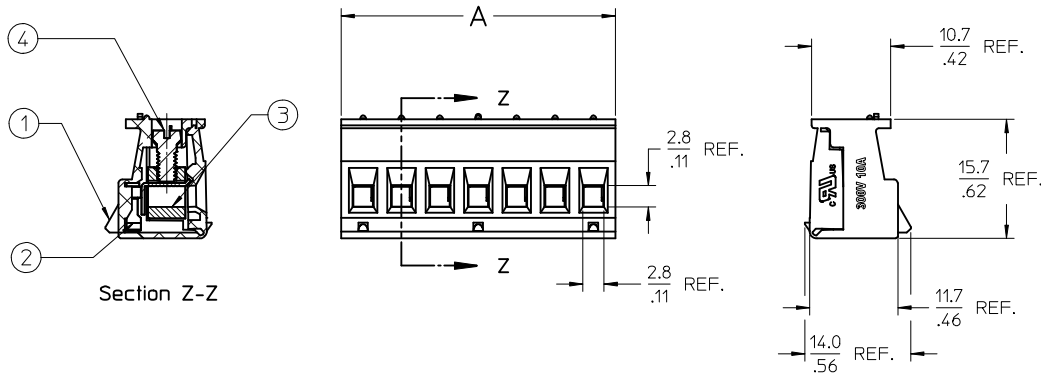
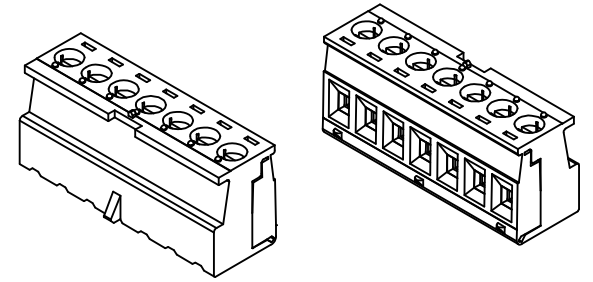
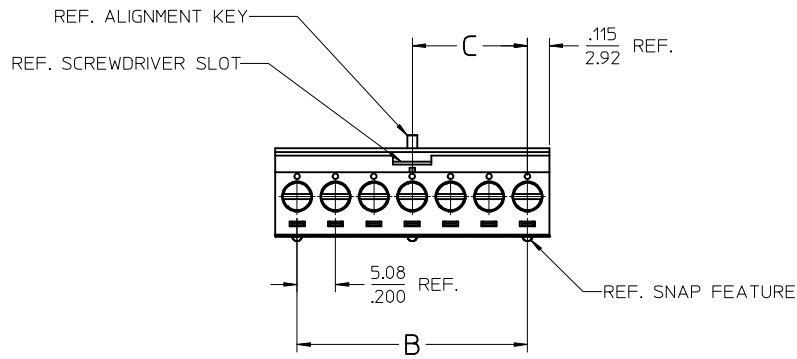

CIRCUITS	PART NO.	DIM-A mm ±0.25	DIM-A IN ±.010	DIM-B mm	DIM-B IN	DIM-C mm	DIM-C IN
2	399800302	10.92	.430	5.08	.200	5.08	.200
3	399800303	16.00	.630	10.16	.400	10.16	.400
4	399800304	21.08	.830	15.24	.600	10.16	.400
5	399800305	26.16	1.030	20.32	.800	10.16	.400
6	399800306	31.24	1.230	25.40	1.000	15.24	.600
7	399800307	36.32	1.430	30.48	1.200	15.24	.600
8	399800308	41.40	1.630	35.56	1.400	20.34	.800
9	399800309	46.48	1.830	40.64	1.600	20.34	.800
10	399800310	51.56	2.030	45.72	1.800	25.40	1.000
11	399800311	56.64	2.230	50.80	2.000	25.40	1.000
12	399800312	61.72	2.430	55.88	2.200	30.48	1.200
13	399800313	66.80	2.630	60.96	2.400	30.48	1.200
14	399800314	71.88	2.830	66.04	2.600	35.56	1.400
15	399800315	76.96	3.030	71.12	2.800	35.56	1.400
16	399800316	82.04	3.230	76.20	3.000	40.64	1.600
17	399800317	87.12	3.430	81.28	3.200	40.64	1.600
18	399800318	92.20	3.630	86.36	3.400	45.72	1.800
19	399800319	97.28	3.830	91.44	3.600	45.72	1.800
20	399800320	102.36	4.030	96.52	3.800	50.80	2.000
21	399800321	107.44	4.230	101.60	4.000	50.80	2.000
22	399800322	112.52	4.430	106.68	4.200	55.88	2.200
23	399800323	117.60	4.630	111.76	4.400	55.88	2.200
24	399800324	122.68	4.830	116.84	4.600	60.96	2.400

NOTES:

- MATERIAL: SEE TABLE
- FINISHES: SEE TABLE
- ELECTRICAL SPECIFICATIONS
VOLTAGE RATING: 300V
CURRENT RATING: 10 AMPS
- WIRE RANGE: 24-12AWG
- WIRE STRIP: 6mm (.25 IN)
- TIGHTENING TORQUE: .45NM (4 IN.LBS)
- XX REFERS TO NUMBER OF CIRCUITS

ITEM	QTY.	DESCRIPTION	MATERIAL	FINISH
4	XX	SCREW, M3 X 0.5	STEEL	ZN, CLEAR CHROMATE
3	XX	CAGE	BRASS	NICKEL PLATED
2	XX	TERMINAL	Cu ALLOY	TIN PLATED
1	1	PLUG BODY	NYLON	BLACK

REDRAWN: REMOVE GOLD OPT	EC NO: IPG2016-1388	2016/04/13
DRWNR: STONE	CHKD: MZILELSKI	2016/04/20
APPR: BRUPERT	2016/04/22	
DESCRIPTION	QUALITY SYMBOLS	
	▽=0	
	▽=0	

GENERAL TOLERANCES (UNLESS SPECIFIED)

	mm	INCH
4 PLACES	± .005	± .0005
3 PLACES	± .005	± .0005
2 PLACES	± 0.13	± .01
1 PLACE	± 0.3	± .0125
0 PLACE	± .005	± .0005

ANGULAR ± .005°

DRAFT WHERE APPLICABLE MUST REMAIN WITHIN DIMENSIONS

DIMENSION STYLE: MM/IN

SCALE: 2:1

DESIGN UNITS: INCH

THIRD ANGLE PROJECTION

DRAWN BY: RSTONE DATE: 2016/04/13

CHECKED BY: MZILELSKI DATE: 2016/04/20

APPROVED BY: BRUPERT DATE: 2016/04/22

MATERIAL NO. SEE TABLE

SINGLE ROW EURO PLUG
5.08MM (.200 IN) PITCH

molex

DOCUMENT NO. SD-39980-012

SHEET NO. 1 OF 1

THIS DRAWING CONTAINS INFORMATION THAT IS PROPRIETARY TO MOLEX INCORPORATED AND SHOULD NOT BE USED WITHOUT WRITTEN PERMISSION