

MATERIAL NUMBER	ENGINEERING NUMBER	MATERIAL NUMBER ON TAPE	ENGINEERING NUMBER ON TAPE	"L" MAX	"S" ±.010 (0.25) (H1)	"W" MAX	"H" ±.010 (0.25)	"T" REF
191640889	SD-656-08	N/A	N/A	1.60 (40.6)	.173 (4.39)	.38 (9.7)	N/A	.045/1.14
191640880	SD-656-10	N/A	N/A	1.60 (40.6)	.198 (5.03)	.38 (9.7)	N/A	.045/1.14
191640881	SD-651-14	191640603	SD-651-14T	1.79 (45.5)	.265 (6.73)	.60 (15.2)	.348 (8.84)	.045/1.14
191640883	SD-651-56	191640605	SD-651-56T	1.79 (45.5)	.328 (8.33)	.60 (15.2)	.348 (8.84)	.045/1.14
191640882	SD-652-38	N/A	N/A	2.05 (51.1)	.390 (9.91)	.82 (20.8)	N/A	.050/1.27
191640839	SD-652-76	N/A	N/A	2.05 (52.1)	.453 (11.51)	.82 (20.8)	N/A	.050/1.27
191640457	SD-652-12	N/A	N/A	2.05 (52.1)	.515 (13.08)	.82 (20.8)	N/A	.050/1.27

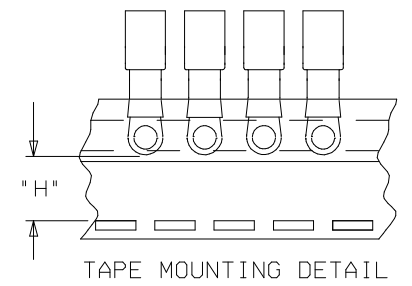
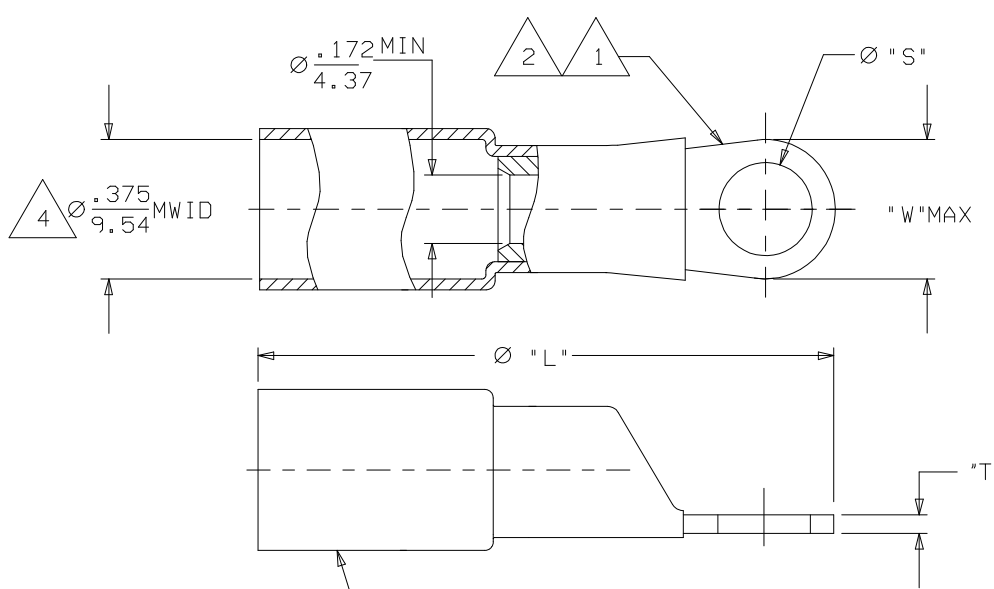

NOTE(S):

- 1 TERMINAL MATERIAL: COPPER ALLOY.
- 2 FINISH: ELECTRO TIN PLATE.
- 3 INSULATION MATERIAL: HEAT SHRINKABLE TUBING WITH HOTMELT ASHESIVE INNER LINER. COLOR: RED.
- 4 MWID = MAXIMUM WIRE INSULATION DIAMETER.
- 5. ASSEMBLY IS ROHS COMPLIANT.

TYPO ALL "S" DIMS	DESCRIPTION
EC NO: PG2014-1619	2014/03/14
DRW: JMWTRICK	2014/03/31
CHKD: JMACNEIL	2014/04/21
APPR: JMACNEIL	
REV	
H1	

QUALITY SYMBOLS
▽=0
▽=0

GENERAL TOLERANCES (UNLESS SPECIFIED)	
mm	INCH
4 PLACES ±---	±---
3 PLACES ±---	±---
2 PLACES ±---	±---
1 PLACE ±---	±---
ANGULAR ±---°	
DRAFT WHERE APPLICABLE MUST REMAIN WITHIN DIMENSIONS	

DIMENSION STYLE	
IN/MM	
DRAWN BY	DATE
R DEROSS	2005/01/04
CHECKED BY	DATE
R DEROSS	2005/01/04
APPROVED BY	DATE
R DEROSS	2005/01/04
MATERIAL NO.	
SEE CHART	
SIZE	B

SCALE	1:1	DESIGN UNITS	INCH	THIRD ANGLE PROJECTION
TITLE				
RING TONGUE TERMINAL PERMA-SEAL SD-600-SERIES 8 AWG				
MOLEX INCORPORATED				
DOCUMENT NO.				SHEET NO.
SD-19164-023				1 OF 1
THIS DRAWING CONTAINS INFORMATION THAT IS PROPRIETARY TO MOLEX INCORPORATED AND SHOULD NOT BE USED WITHOUT WRITTEN PERMISSION				