

PCB LAYOUT: COMPONENT SIDE
 *** = TO BE DETERMINED BY CUSTOMER

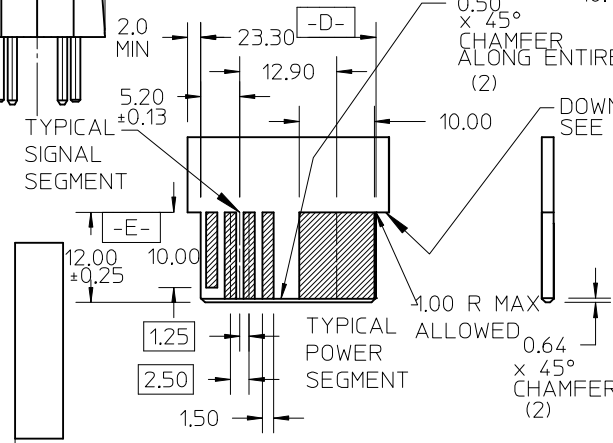

RECOMMENDED EDGE CARD LAYOUT:
 EDGE CARD THICKNESS: 1.571,062
 PLATING: GOLD 30 μINCHES MIN
 OVER 150 μINCHES NICKEL

MOLEX P/N 45911-0001 SHOWN

- NOTES:
- MATERIAL: HOUSING - LCP, UL94V-0, BLACK
 MATERIAL: TERMINALS - COPPER ALLOY
 - FINISH: SELECT GOLD: 30 MI MIN IN CONTACT AREA
 SELECT TIN: 150 MI MIN IN PC TAIL AREA
 BOTH OVER NICKEL: 50 MI MIN
 - PRODUCT SPECIFICATION: PS-45719-001.
 - PACKAGING SPECIFICATION: ES-45714-001.
 - PCB THICKNESS: SEE CHART
 - EDGE CARD THICKNESS: 1.57±0.08
 - DIMENSIONS GIVEN ACROSS CENTERLINES ARE SYMMETRICAL ABOUT THOSE CENTERLINES WITHIN HALF THE TOTAL TOLERANCE.
 - PCB HOLE SIZE SPECIFICATION: SEE PS-45719-001
 - POWER TERMINALS ARE LUBRICATED.
 - THIS EDGE WILL TOUCH HOUSING WHEN EDGE CARD IS FULLY SEATED

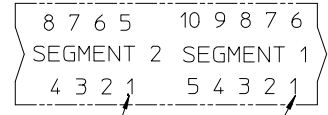

SEGMENT 2 - CIRCUIT 1
 SEGMENT 1 - CIRCUIT 1

TOOLING STATUS	MATERIAL NUMBER	SEGMENT	SEGMENT	DIM P / DIM T	PCB THK
TOOLED	45911-0001	SIGNAL	POWER	4.50	3.18
TOOLED	45911-0002	POWER	SIGNAL	4.33	2.36
TOOLED	45911-0003	SIGNAL	POWER	3.19	1.57
TOOLED	45911-0004	POWER	SIGNAL	3.19	

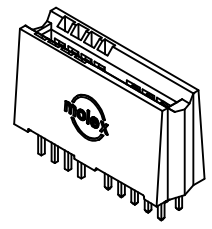

DEL 5, 6 CKT PARTS
 EC NO: UCP2015-2755
 DRWN: JSCHAFFER 2015/08/07
 CHKD: APPR: APATEL 2015/09/01
 K5

QUALITY SYMBOLS	DESCRIPTION

GENERAL TOLERANCES (UNLESS SPECIFIED)	DIMENSION STYLE	
	MM ONLY	SCALE
4 PLACES ± ---	INCH	2:1
3 PLACES ± ---	DATE	DESIGN UNITS
2 PLACES ± 0.25	DATE	METRIC
1 PLACE ± 0.25	DATE	THIRD ANGLE PROJECTION
ANGULAR ± 1/2°	DATE	
DRAFT WHERE APPLICABLE MUST REMAIN WITHIN DIMENSIONS	DATE	

DRAWN BY	DATE	TITLE
SAMIEC	2005/04/14	POWER EDGE ASSEMBLY POWER / SIGNAL MIXED VERTICAL SOLDER TAIL
CHECKED BY	DATE	MOLEX INCORPORATED
SAMIEC	2005/04/14	
APPROVED BY	DATE	DOCUMENT NO.
MARGULIS	2005/04/14	SD-45911-001
MATERIAL NUMBER	SEE CHART	SHEET NO.
SIZE		1 OF 4

THIS DRAWING CONTAINS INFORMATION THAT IS PROPRIETARY TO MOLEX INCORPORATED AND SHOULD NOT BE USED WITHOUT WRITTEN PERMISSION

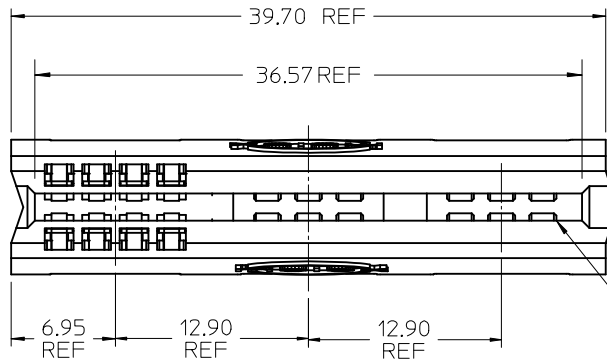

RECOMMENDED
EDGE CARD
LAYOUT
SEE SHT 1 FOR ADDITIONAL DETAILS
TOLERANCE: ±0.05

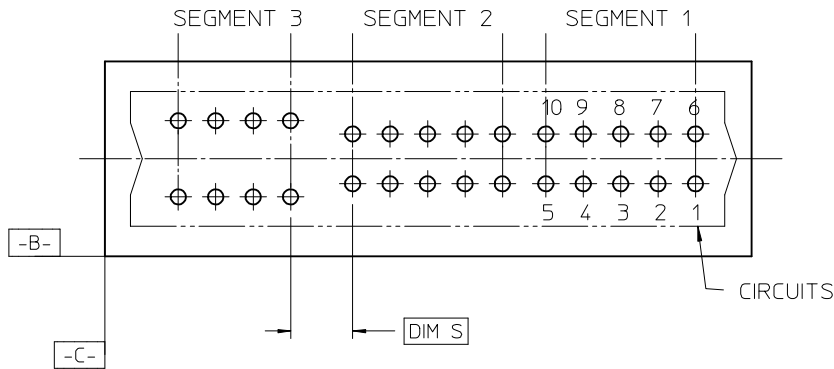
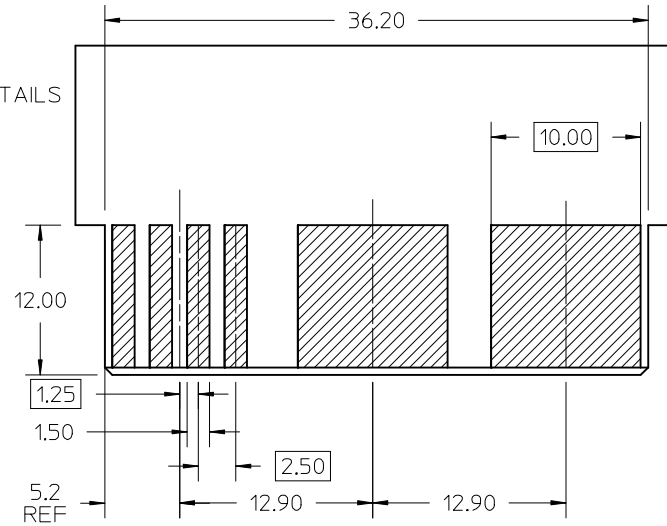

DIM S BETWEEN SIGNAL SEG AND SIGNAL SEG: 5.40
DIM S BETWEEN POWER SEG AND POWER SEG: 2.90
DIM S BETWEEN SIGNAL SEG AND POWER SEG: 4.15

PCB LAYOUT: COMPONENT SIDE

MATERIAL NUMBER: 45911-0007 SHOWN
SEE SHEET ONE FOR ALL OTHER NOTES AND DIMENSIONS

TOOLING STATUS	MATERIAL NUMBER	SEGMENT 3	SEGMENT 2	SEGMENT 1	DIM P / DIM T	PCB THK
TOOLED	45911-0007	SIGNAL	POWER	POWER	4.50 / 4.33	3.18 / 2.36
TOOLED	45911-0008	POWER	SIGNAL	POWER		
TOOLED	45911-0009	SIGNAL	SIGNAL	POWER		
TOOLED	45911-0010	SIGNAL	POWER	SIGNAL		
TOOLED	45911-0011	POWER	SIGNAL	SIGNAL	3.19 / 3.19	1.57
TOOLED	45911-0012	POWER	POWER	SIGNAL		
TOOLED	45911-0013	SIGNAL	POWER	POWER		
TOOLED	45911-0014	POWER	SIGNAL	POWER		
TOOLED	45911-0015	SIGNAL	SIGNAL	POWER	3.19 / 3.19	1.57
TOOLED	45911-0016	SIGNAL	POWER	SIGNAL		
TOOLED	45911-0017	POWER	SIGNAL	SIGNAL		
TOOLED	45911-0018	POWER	POWER	SIGNAL		

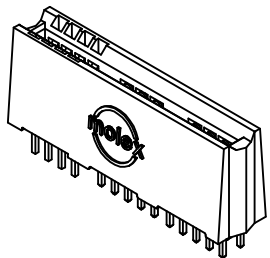

EC NO: UCP2015-2755 DRWN: JSCHAFFER 2015/08/07 CHKD: APPR: APATEL 2015/09/01 DESCRIPTION REV K5	QUALITY SYMBOLS	GENERAL TOLERANCES (UNLESS SPECIFIED)		DIMENSION STYLE MM ONLY		SCALE 1:1	DESIGN UNITS METRIC	THIRD ANGLE PROJECTION
		mm	INCH	DRAWN BY SAMIEC	DATE 2005/04/14	TITLE POWER EDGE ASSEMBLY POWER / SIGNAL MIXED VERTICAL SOLDER TAIL		
	4 PLACES	± ---	± ---	CHECKED BY	DATE			
	3 PLACES	± ---	± ---	SAMIEC	2005/04/14	MOLEX INCORPORATED		
	2 PLACES	± 0.25	± ---	APPROVED BY	DATE			
1 PLACE	± 0.25	± ---	MARGULIS	2005/04/14	DOCUMENT NO. SD-45911-001		SHEET NO. 2 OF 4	
DRAFT WHERE APPLICABLE MUST REMAIN WITHIN DIMENSIONS		ANGULAR ±1/2°		MATERIAL NUMBER SEE CHART		THIS DRAWING CONTAINS INFORMATION THAT IS PROPRIETARY TO MOLEX INCORPORATED AND SHOULD NOT BE USED WITHOUT WRITTEN PERMISSION		

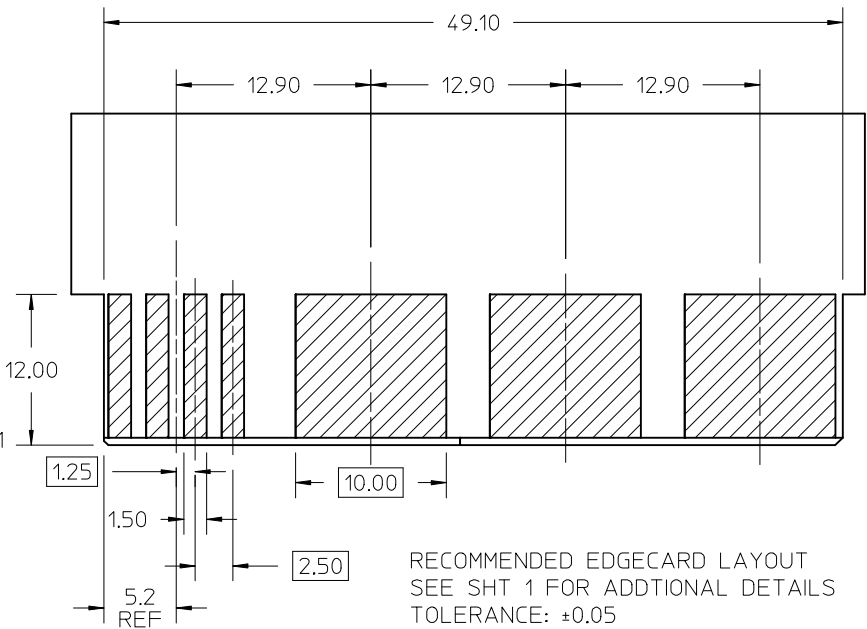
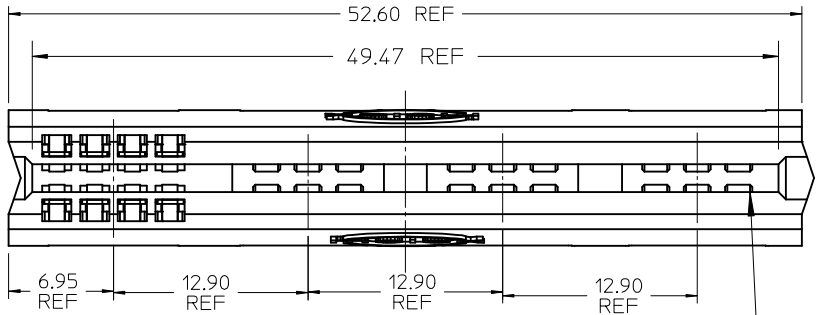

RECOMMENDED EDGE CARD LAYOUT
SEE SHT 1 FOR ADDITIONAL DETAILS
TOLERANCE: ±0.05

SEE CHART ON SHEET 4
FOR MATERIAL NUMBERS

PART NUMBER 45911-0025
SHOWN FOR REFERENCE

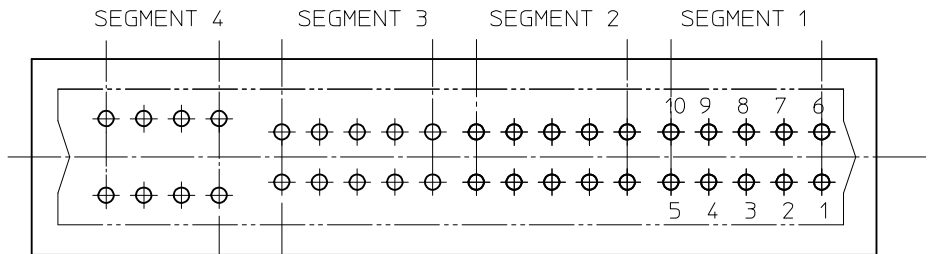

DIM S BETWEEN SIGNAL SEG AND SIGNAL SEG: 5.40
DIM S BETWEEN POWER SEG AND POWER SEG: 2.90
DIM S BETWEEN SIGNAL SEG AND POWER SEG: 4.15

PCB LAYOUT: COMPONENT SIDE

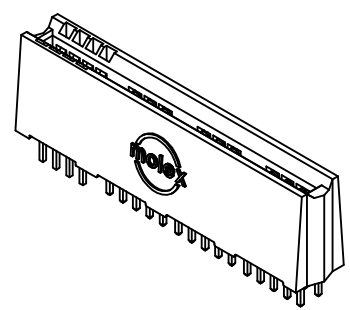

EC NO: UCP2015-2755 DRWN: JSCHAFFER 2015/08/07 CHKD: APPR: APATEL 2015/09/01 K5 REV	QUALITY SYMBOLS DESCRIPTION	GENERAL TOLERANCES (UNLESS SPECIFIED)		DIMENSION STYLE MM ONLY		SCALE 2:1	DESIGN UNITS METRIC	THIRD ANGLE PROJECTION		
			mm	INCH	DRAWN BY SAMIEC	DATE 2005/04/14	TITLE POWER EDGE ASSEMBLY POWER / SIGNAL MIXED VERTICAL SOLDER TAIL			
		4 PLACES	± ---	± ---	CHECKED BY SAMIEC	DATE 2005/04/14				
		3 PLACES	± ---	± ---	APPROVED BY MARGULIS	DATE 2005/04/14	molex MOLEX INCORPORATED			
		2 PLACES	± 0.25	± ---	MATERIAL NUMBER SEE CHART ON SHEET 4					
1 PLACE	± 0.25	± ---	ANGULAR ±1/2°		THIS DRAWING CONTAINS INFORMATION THAT IS PROPRIETARY TO MOLEX INCORPORATED AND SHOULD NOT BE USED WITHOUT WRITTEN PERMISSION					

DRAFT WHERE APPLICABLE
MUST REMAIN
WITHIN DIMENSIONS

	6		5			4		
	TOOLING STATUS	MATERIAL NUMBER	SEGMENT 4	SEGMENT 3	SEGMENT 2	SEGMENT 1	$\frac{DIM P}{DIM T}$ PCB THK	
D	TOOLED	45911-0025	SIGNAL	POWER	POWER	POWER	$\frac{4.50}{4.33}$ 3.18 2.36	
	TOOLED	45911-0026	POWER	SIGNAL	POWER	POWER		
	TOOLED	45911-0027	SIGNAL	SIGNAL	POWER	POWER		
	TOOLED	45911-0028	SIGNAL	POWER	SIGNAL	POWER		
	TOOLED	45911-0029	POWER	SIGNAL	SIGNAL	POWER		
	TOOLED	45911-0030	POWER	POWER	SIGNAL	POWER		
	TOOLED	45911-0031	SIGNAL	SIGNAL	SIGNAL	POWER		
	TOOLED	45911-0032	SIGNAL	POWER	POWER	SIGNAL		
	TOOLED	45911-0033	POWER	SIGNAL	POWER	SIGNAL		
	TOOLED	45911-0034	SIGNAL	SIGNAL	POWER	SIGNAL		
C	TOOLED	45911-0035	SIGNAL	POWER	SIGNAL	SIGNAL		
	TOOLED	45911-0036	POWER	SIGNAL	SIGNAL	SIGNAL		
	TOOLED	45911-0037	POWER	POWER	SIGNAL	SIGNAL		
	TOOLED	45911-0038	POWER	POWER	POWER	SIGNAL		

	3		2			1		
	TOOLING STATUS	MATERIAL NUMBER	SEGMENT 4	SEGMENT 3	SEGMENT 2	SEGMENT 1	$\frac{DIM P}{DIM T}$ PCB THK	
D	TOOLED	45911-0039	SIGNAL	POWER	POWER	POWER	$\frac{3.19}{3.19}$ 1.57	
	TOOLED	45911-0040	POWER	SIGNAL	POWER	POWER		
	TOOLED	45911-0041	SIGNAL	SIGNAL	POWER	POWER		
	TOOLED	45911-0042	SIGNAL	POWER	SIGNAL	POWER		
	TOOLED	45911-0043	POWER	SIGNAL	SIGNAL	POWER		
	TOOLED	45911-0044	POWER	POWER	SIGNAL	POWER		
	TOOLED	45911-0045	SIGNAL	SIGNAL	SIGNAL	POWER		
	TOOLED	45911-0046	SIGNAL	POWER	POWER	SIGNAL		
	TOOLED	45911-0047	POWER	SIGNAL	POWER	SIGNAL		
	TOOLED	45911-0048	SIGNAL	SIGNAL	POWER	SIGNAL		
C	TOOLED	45911-0049	SIGNAL	POWER	SIGNAL	SIGNAL		
	TOOLED	45911-0050	POWER	SIGNAL	SIGNAL	SIGNAL		
	TOOLED	45911-0051	POWER	POWER	SIGNAL	SIGNAL		
	TOOLED	45911-0052	POWER	POWER	POWER	SIGNAL		



EC NO: UCP2015-2755 DRWN: JSCHAFFER CHKD: APPR: APATEL 2015/09/01 DESCRIPTION REV	GENERAL TOLERANCES (UNLESS SPECIFIED)		DIMENSION STYLE MM ONLY		SCALE 1:1	DESIGN UNITS METRIC	THIRD ANGLE PROJECTION	
		mm	INCH	DRAWN BY SAMIEC	DATE 2005/04/14	TITLE POWER EDGE ASSEMBLY POWER / SIGNAL MIXED VERTICAL SOLDER TAIL		
	4 PLACES	± ---	± ---	CHECKED BY SAMIEC	DATE 2005/04/14			
	3 PLACES	± ---	± ---					
	2 PLACES	± 0.25	± ---					
	1 PLACE	± 0.25	± ---	MARGULIS	2005/04/14	MOLEX INCORPORATED 		
DRAFT WHERE APPLICABLE MUST REMAIN WITHIN DIMENSIONS		SEE CHART		DOCUMENT NO. SD-45911-001		SHEET NO. 4 OF 4		
SIZE A		THIS DRAWING CONTAINS INFORMATION THAT IS PROPRIETARY TO MOLEX INCORPORATED AND SHOULD NOT BE USED WITHOUT WRITTEN PERMISSION						

6

5

4

3

2

1

D

D

C

C

B

B

A

A

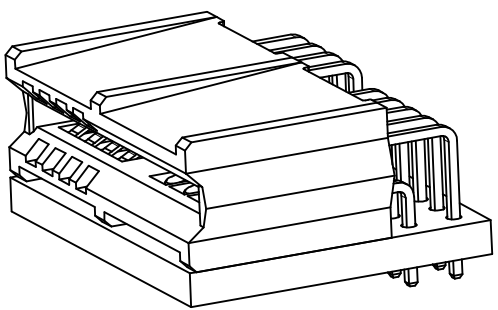
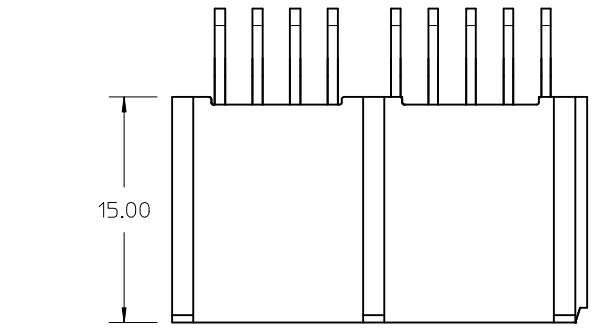

- NOTES:
- MATERIAL: HOUSING - LCP, UL94V-0, BLACK
MATERIAL: TERMINALS - COPPER ALLOY
 - FINISH: SELECT GOLD: 30 MI MIN IN CONTACT AREA
SELECT TIN: 150 MI MIN IN PC TAIL AREA
BOTH OVER NICKEL: 50 MI MIN
 - PRODUCT SPECIFICATION: PS-45719-001.
 - PACKAGING SPECIFICATION: PK-45714-001.
 - PCB THICKNESS: SEE CHART
 - EDGE CARD THICKNESS: 1.57±0.15
 - DIMENSIONS GIVEN ACROSS CENTERLINES ARE SYMMETRICAL ABOUT THOSE CENTERLINES WITHIN HALF THE TOTAL TOLERANCE.
 - 0.50 X 45°CHAMFER ON LEADING EDGE, TYP 4 SIDES.

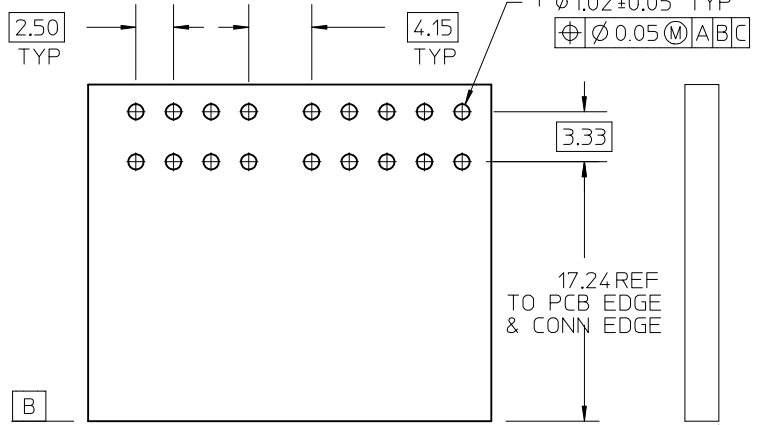
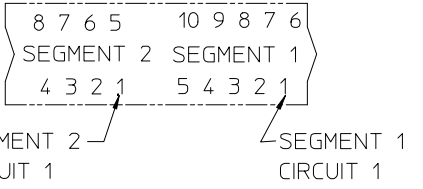
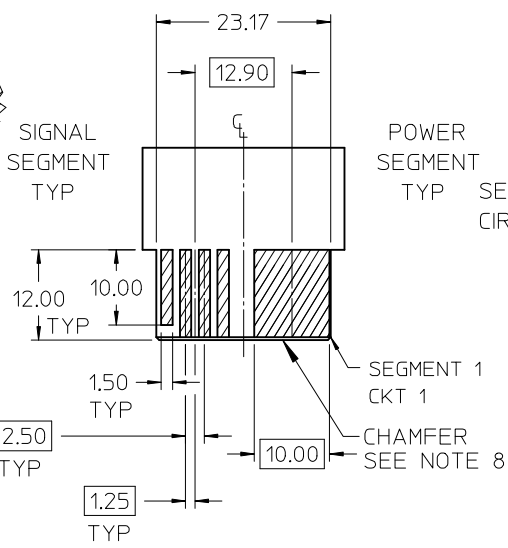
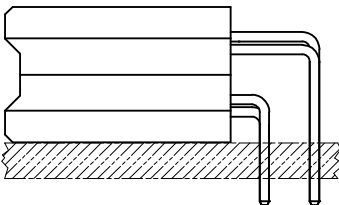
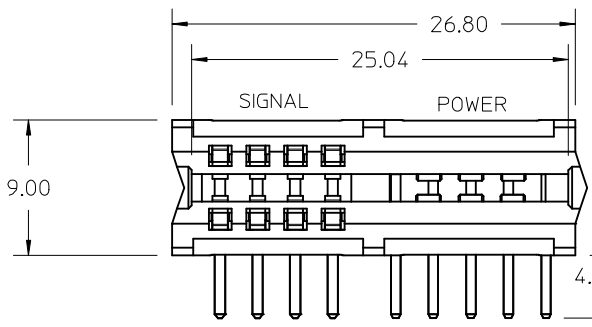

MATERIAL NUMBER	SEGMENT 2	SEGMENT 1
45911-0901	SIGNAL	POWER
45911-0902	POWER	SIGNAL
45911-0903	SIGNAL	POWER
45911-0904	POWER	SIGNAL
SEE 45844	SIGNAL	SIGNAL
SEE 45719	POWER	POWER

EDGE CARD LAYOUT:
TOLERANCE: ±0.05

INITIAL RELEASE	2014/08/25
EC NO: UCP2015-0425	2011/11/07
DRWN: JSCHAFFER	
CHKD: APATEL	
APPR: APATEL	
REV 1	

QUALITY SYMBOLS	DESCRIPTION

GENERAL TOLERANCES (UNLESS SPECIFIED)		
	mm	INCH
4 PLACES	± ---	± ---
3 PLACES	± ---	± ---
2 PLACES	± 0.25	± ---
1 PLACE	± 0.25	± ---
ANGULAR ±1/2°		
DRAFT WHERE APPLICABLE MUST REMAIN WITHIN DIMENSIONS		

DIMENSION STYLE	
MM ONLY	
DRAWN BY	DATE
JSCHAFFER	2011/11/07
CHECKED BY	DATE
APPROVED BY	DATE
APATEL	2014/08/25
MATERIAL NUMBER	SEE CHART
SIZE	A

SCALE	2:1	DESIGN UNITS	METRIC	THIRD ANGLE PROJECTION
TITLE				
POWER EDGE ASSEMBLY POWER / SIGNAL MIXED RT ANGLE SOLDER TAIL				
MOLEX INCORPORATED				
MATERIAL NUMBER			DOCUMENT NO.	SHEET NO.
SEE CHART			SD-45911-002	1 OF 5
THIS DRAWING CONTAINS INFORMATION THAT IS PROPRIETARY TO MOLEX INCORPORATED AND SHOULD NOT BE USED WITHOUT WRITTEN PERMISSION				

5

4

3

2

1

MATERIAL NUMBER: 45911-0907 SHOWN
 SEE SHEET ONE FOR ALL OTHER NOTES AND DIMENSIONS

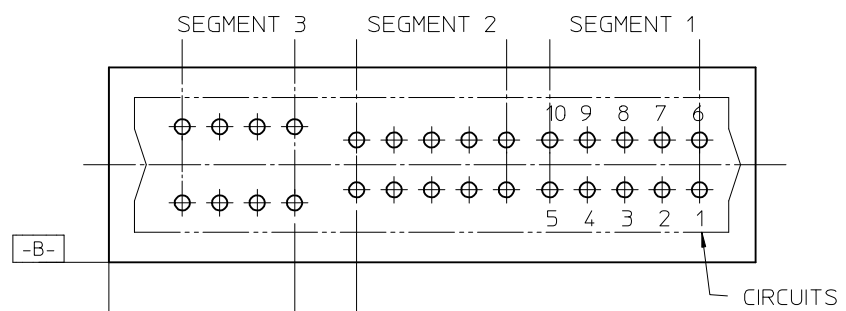
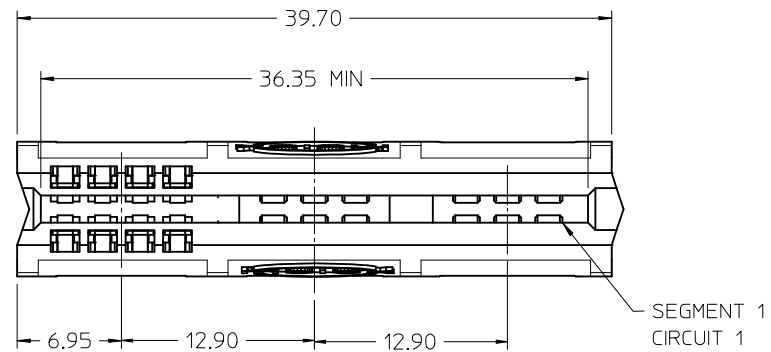

DIM S BETWEEN SIGNAL SEG AND SIGNAL SEG: 5.40
 DIM S BETWEEN POWER SEG AND POWER SEG: 2.90
 DIM S BETWEEN SIGNAL SEG AND POWER SEG: 4.15

PCB LAYOUT: COMPONENT SIDE

MATERIAL NUMBER	SEGMENT 3	SEGMENT 2	SEGMENT 1	DIM P DIM T	PCB THK
45911-0907	SIGNAL	POWER	POWER	4.50 4.33	3.18 2.36
45911-0908	POWER	SIGNAL	POWER		
45911-0909	SIGNAL	SIGNAL	POWER		
45911-0910	SIGNAL	POWER	SIGNAL		
45911-0911	POWER	SIGNAL	SIGNAL	3.19 3.19	1.57
45911-0912	POWER	POWER	SIGNAL		
45911-0913	SIGNAL	POWER	POWER		
45911-0914	POWER	SIGNAL	POWER		
45911-0915	SIGNAL	SIGNAL	POWER		
45911-0916	SIGNAL	POWER	SIGNAL		
45911-0917	POWER	SIGNAL	SIGNAL		
45911-0918	POWER	POWER	SIGNAL		

EC NO: UCP2015-0425 DRWN: JSCHAFFER 2011/11/07 CHKD: APPR: APATEL 2014/08/25 DESCRIPTION REV 1	QUALITY SYMBOLS	GENERAL TOLERANCES (UNLESS SPECIFIED)		DIMENSION STYLE MM ONLY		SCALE 1:1	DESIGN UNITS METRIC	THIRD ANGLE PROJECTION	
		mm	INCH	DRAWN BY JSCHAFFER	DATE 2011/11/07	TITLE POWER EDGE ASSEMBLY POWER / SIGNAL MIXED RT ANGLE SOLDER TAIL			
	4 PLACES	± ---	± ---	CHECKED BY	DATE				
	3 PLACES	± ---	± ---	APPROVED BY APATEL		DATE 2014/08/25	MOLEX INCORPORATED		
	2 PLACES	± 0.25	± ---	MATERIAL NUMBER SEE CHART		DOCUMENT NO. SD-45911-002			
1 PLACE	± 0.25	± ---	DRAFT WHERE APPLICABLE MUST REMAIN WITHIN DIMENSIONS		SIZE A	THIS DRAWING CONTAINS INFORMATION THAT IS PROPRIETARY TO MOLEX INCORPORATED AND SHOULD NOT BE USED WITHOUT WRITTEN PERMISSION			

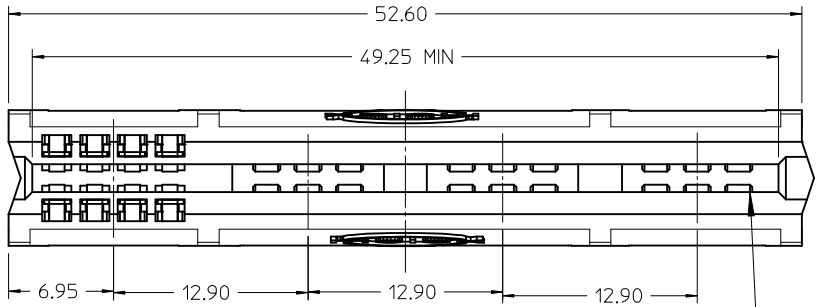

SEGMENT 1
CIRCUIT 1

SEE CHART ON SHEET 4
FOR MATERIAL NUMBERS

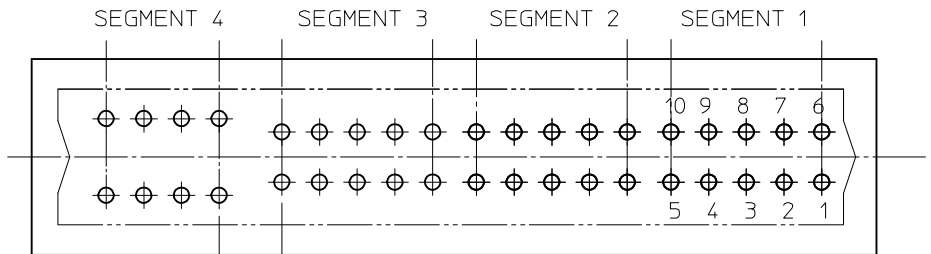

-B-

DIM S

DIM S BETWEEN SIGNAL SEG AND SIGNAL SEG: 5.40
 DIM S BETWEEN POWER SEG AND POWER SEG: 2.90
 DIM S BETWEEN SIGNAL SEG AND POWER SEG: 4.15

PCB LAYOUT: COMPONENT SIDE

EC NO: UCP2015-0425 DRWN: JSCHAFFER 2011/11/07 CHKD: APATEL APPR: APATEL 2014/08/25 1	DESCRIPTION QUALITY SYMBOLS	GENERAL TOLERANCES (UNLESS SPECIFIED)		DIMENSION STYLE MM ONLY		SCALE 2:1	DESIGN UNITS METRIC	THIRD ANGLE PROJECTION			
			mm	INCH	DRAWN BY JSCHAFFER	DATE 2011/11/07	TITLE POWER EDGE ASSEMBLY POWER / SIGNAL MIXED RT ANGLE SOLDER TAIL				
		4 PLACES	± ---	± ---	CHECKED BY	DATE					
		3 PLACES	± ---	± ---	APPROVED BY APATEL		DATE 2014/08/25	MOLEX INCORPORATED			
		2 PLACES	± 0.25	± ---	MATERIAL NUMBER SEE CHART ON SHEET 4		DOCUMENT NO. SD-45911-002				
1 PLACE	± 0.25	± ---	DRAFT WHERE APPLICABLE MUST REMAIN WITHIN DIMENSIONS		SIZE A	THIS DRAWING CONTAINS INFORMATION THAT IS PROPRIETARY TO MOLEX INCORPORATED AND SHOULD NOT BE USED WITHOUT WRITTEN PERMISSION					

6		5			4		3		2			1	
MATERIAL NUMBER	SEGMENT 4	SEGMENT 3	SEGMENT 2	SEGMENT 1	$\frac{DIM P}{DIM T}$	PCB THK	MATERIAL NUMBER	SEGMENT 4	SEGMENT 3	SEGMENT 2	SEGMENT 1	$\frac{DIM P}{DIM T}$	PCB THK
45911-0925	SIGNAL	POWER	POWER	POWER	$\frac{4.50}{4.33}$	3.18 2.36	45911-0939	SIGNAL	POWER	POWER	POWER	$\frac{3.19}{3.19}$	1.57
45911-0926	POWER	SIGNAL	POWER	POWER			45911-0940	POWER	SIGNAL	POWER	POWER		
45911-0927	SIGNAL	SIGNAL	POWER	POWER			45911-0941	SIGNAL	SIGNAL	POWER	POWER		
45911-0928	SIGNAL	POWER	SIGNAL	POWER			45911-0942	SIGNAL	POWER	SIGNAL	POWER		
45911-0929	POWER	SIGNAL	SIGNAL	POWER			45911-0943	POWER	SIGNAL	SIGNAL	POWER		
45911-0930	POWER	POWER	SIGNAL	POWER			45911-0944	POWER	POWER	SIGNAL	POWER		
45911-0931	SIGNAL	SIGNAL	SIGNAL	POWER			45911-0945	SIGNAL	SIGNAL	SIGNAL	POWER		
45911-0932	SIGNAL	POWER	POWER	SIGNAL			45911-0946	SIGNAL	POWER	POWER	SIGNAL		
45911-0933	POWER	SIGNAL	POWER	SIGNAL			45911-0947	POWER	SIGNAL	POWER	SIGNAL		
45911-0934	SIGNAL	SIGNAL	POWER	SIGNAL			45911-0948	SIGNAL	SIGNAL	POWER	SIGNAL		
45911-0935	SIGNAL	POWER	SIGNAL	SIGNAL			45911-0949	SIGNAL	POWER	SIGNAL	SIGNAL		
45911-0936	POWER	SIGNAL	SIGNAL	SIGNAL			45911-0950	POWER	SIGNAL	SIGNAL	SIGNAL		
45911-0937	POWER	POWER	SIGNAL	SIGNAL			45911-0951	POWER	POWER	SIGNAL	SIGNAL		
45911-0938	POWER	POWER	POWER	SIGNAL			45911-0952	POWER	POWER	POWER	SIGNAL		



EC NO: UCP2015-0425 DRWN: JSCHAFFER CHKD: APPR: APATEL 2014/08/25 DESCRIPTION REV	GENERAL TOLERANCES (UNLESS SPECIFIED)	DIMENSION STYLE MM ONLY	SCALE 1:1	DESIGN UNITS METRIC	THIRD ANGLE PROJECTION
		mm	INCH	TITLE	
	4 PLACES ± --- ± ---	DRAWN BY DATE JSCHAFFER 2011/11/07		POWER EDGE ASSEMBLY POWER / SIGNAL MIXED RT ANGLE SOLDER TAIL	
	3 PLACES ± --- ± ---	CHECKED BY DATE			
	2 PLACES ± 0.25 ± ---	APATEL 2014/08/25		MOLEX INCORPORATED	
1 PLACE ± 0.25 ± ---	MATERIAL NO. SEE CHART		DOCUMENT NO. SD-45911-002	SHEET NO. 4 OF 5	
1	ANGULAR ± 1/2°	THIS DRAWING CONTAINS INFORMATION THAT IS PROPRIETARY TO MOLEX INCORPORATED AND SHOULD NOT BE USED WITHOUT WRITTEN PERMISSION			
	DRAFT WHERE APPLICABLE MUST REMAIN WITHIN DIMENSIONS				

MATERIAL NUMBER	SEG 5	SEG 4	SEG 3	SEG 2	SEG 1
45911-0954	POWER	SIGNAL	SIGNAL	SIGNAL	SIGNAL
45911-0955	SIGNAL	SIGNAL	POWER	POWER	POWER
45911-0956	POWER	POWER	SIGNAL	POWER	POWER
45911-0957	SIGNAL	SIGNAL	SIGNAL	POWER	POWER
45911-0957	SIGNAL	SIGNAL	POWER	SIGNAL	POWER
45911-0958	POWER	POWER	SIGNAL	SIGNAL	POWER
45911-0959	POWER	POWER	POWER	SIGNAL	POWER
45911-0960	SIGNAL	SIGNAL	SIGNAL	SIGNAL	POWER
45911-0961	SIGNAL	SIGNAL	POWER	POWER	SIGNAL
45911-0962	POWER	POWER	SIGNAL	POWER	SIGNAL
45911-0963	SIGNAL	SIGNAL	SIGNAL	POWER	SIGNAL
45911-0964	SIGNAL	SIGNAL	POWER	SIGNAL	SIGNAL
45911-0965	POWER	POWER	SIGNAL	SIGNAL	SIGNAL
45911-0966	POWER	POWER	POWER	SIGNAL	SIGNAL
45911-0967	POWER	POWER	POWER	POWER	SIGNAL
45911-0968	POWER	POWER	POWER	SIGNAL	POWER
45911-0969	POWER	POWER	SIGNAL	POWER	POWER
45911-0970	POWER	SIGNAL	SIGNAL	SIGNAL	POWER
45911-0971	POWER	SIGNAL	POWER	SIGNAL	SIGNAL
45911-0972	POWER	SIGNAL	POWER	POWER	POWER
45911-0973	POWER	SIGNAL	POWER	SIGNAL	POWER
45911-0974	POWER	POWER	POWER	SIGNAL	POWER
45911-0975	SIGNAL	POWER	SIGNAL	POWER	SIGNAL
45911-0976	SIGNAL	SIGNAL	SIGNAL	SIGNAL	SIGNAL



5-SEGMENT ASSEMBLIES

MATERIAL NUMBER	SEG 6	SEG 5	SEG 4	SEG 3	SEG 2	SEG 1
45911-0977	POWER	SIGNAL	SIGNAL	SIGNAL	SIGNAL	SIGNAL
45911-0978	SIGNAL	POWER	SIGNAL	SIGNAL	SIGNAL	SIGNAL
45911-0979	SIGNAL	SIGNAL	POWER	SIGNAL	SIGNAL	SIGNAL
45911-0980	SIGNAL	SIGNAL	SIGNAL	POWER	SIGNAL	SIGNAL
45911-0981	SIGNAL	SIGNAL	SIGNAL	SIGNAL	POWER	SIGNAL
45911-0982	SIGNAL	SIGNAL	SIGNAL	SIGNAL	POWER	POWER
45911-0983	POWER	POWER	SIGNAL	SIGNAL	SIGNAL	SIGNAL
45911-0984	POWER	SIGNAL	POWER	SIGNAL	SIGNAL	SIGNAL
45911-0985	POWER	SIGNAL	SIGNAL	POWER	SIGNAL	SIGNAL
45911-0986	POWER	SIGNAL	SIGNAL	SIGNAL	POWER	SIGNAL
45911-0987	POWER	SIGNAL	SIGNAL	SIGNAL	SIGNAL	POWER
45911-0988	SIGNAL	POWER	POWER	SIGNAL	SIGNAL	SIGNAL
45911-0989	SIGNAL	POWER	SIGNAL	POWER	SIGNAL	SIGNAL
45911-0990	SIGNAL	POWER	SIGNAL	SIGNAL	POWER	SIGNAL
45911-0991	SIGNAL	POWER	SIGNAL	SIGNAL	SIGNAL	POWER
45911-0992	SIGNAL	SIGNAL	POWER	POWER	SIGNAL	SIGNAL
45911-0993	SIGNAL	SIGNAL	POWER	SIGNAL	POWER	SIGNAL
45911-0994	SIGNAL	SIGNAL	POWER	SIGNAL	SIGNAL	POWER
45911-0995	SIGNAL	POWER	POWER	SIGNAL	SIGNAL	SIGNAL
45911-0996	SIGNAL	SIGNAL	SIGNAL	POWER	POWER	SIGNAL
45911-0997	SIGNAL	SIGNAL	SIGNAL	SIGNAL	POWER	POWER
45911-0998	SIGNAL	SIGNAL	SIGNAL	POWER	SIGNAL	POWER
45911-0999	POWER	POWER	POWER	SIGNAL	SIGNAL	SIGNAL
45911-9901	SIGNAL	POWER	POWER	POWER	SIGNAL	SIGNAL
45911-9902	SIGNAL	SIGNAL	POWER	POWER	POWER	SIGNAL
45911-9903	SIGNAL	SIGNAL	SIGNAL	POWER	POWER	POWER
45911-9904	POWER	POWER	SIGNAL	POWER	SIGNAL	SIGNAL
45911-9905	POWER	POWER	SIGNAL	SIGNAL	POWER	SIGNAL
45911-9906	POWER	POWER	SIGNAL	SIGNAL	SIGNAL	POWER
45911-9907	SIGNAL	POWER	POWER	SIGNAL	POWER	SIGNAL
45911-9908	SIGNAL	POWER	POWER	SIGNAL	SIGNAL	POWER
45911-9909	SIGNAL	SIGNAL	POWER	POWER	SIGNAL	POWER
45911-9910	POWER	SIGNAL	POWER	POWER	SIGNAL	SIGNAL

MATERIAL NUMBER	SEG 6	SEG 5	SEG 4	SEG 3	SEG 2	SEG 1
45911-9911	POWER	SIGNAL	SIGNAL	POWER	POWER	SIGNAL
45911-9912	SIGNAL	POWER	SIGNAL	POWER	POWER	SIGNAL
45911-9913	POWER	SIGNAL	SIGNAL	SIGNAL	POWER	POWER
45911-9914	SIGNAL	POWER	SIGNAL	SIGNAL	POWER	POWER
45911-9915	SIGNAL	SIGNAL	POWER	SIGNAL	POWER	POWER
45911-9916	POWER	POWER	POWER	POWER	SIGNAL	SIGNAL
45911-9917	SIGNAL	POWER	POWER	POWER	POWER	SIGNAL
45911-9918	SIGNAL	SIGNAL	SIGNAL	POWER	POWER	POWER
45911-9919	POWER	POWER	POWER	SIGNAL	POWER	SIGNAL
45911-9920	POWER	POWER	POWER	SIGNAL	SIGNAL	POWER
45911-9921	POWER	POWER	POWER	POWER	SIGNAL	POWER
45911-9922	POWER	POWER	SIGNAL	POWER	SIGNAL	POWER
45911-9923	POWER	POWER	SIGNAL	SIGNAL	POWER	POWER
45911-9924	POWER	SIGNAL	POWER	POWER	POWER	SIGNAL
45911-9925	POWER	SIGNAL	SIGNAL	POWER	POWER	POWER
45911-9926	POWER	SIGNAL	POWER	POWER	SIGNAL	POWER
45911-9927	POWER	POWER	SIGNAL	POWER	POWER	SIGNAL
45911-9928	POWER	SIGNAL	SIGNAL	POWER	POWER	POWER
45911-9929	POWER	POWER	POWER	POWER	POWER	POWER
45911-9930	POWER	POWER	POWER	SIGNAL	POWER	POWER
45911-9931	POWER	POWER	POWER	POWER	SIGNAL	POWER
45911-9932	POWER	POWER	POWER	POWER	POWER	SIGNAL
45911-9933	SIGNAL	POWER	POWER	POWER	POWER	POWER
45911-9934	SIGNAL	SIGNAL	SIGNAL	SIGNAL	SIGNAL	SIGNAL

6-SEGMENT ASSEMBLIES

ENTER DESCRIPTION
 EC NO: UCP2015-0425
 DRWN: JSCHAFFER 2011/11/07
 CHKD: JSCHAFFER
 APPR: APATEL 2014/08/25
 REV 1

QUALITY SYMBOLS



GENERAL TOLERANCES (UNLESS SPECIFIED)

	mm	INCH
4 PLACES	± .005	± .0005
3 PLACES	± .005	± .0005
2 PLACES	± 0.25	± .010
1 PLACE	± 0.25	± .010

 ANGULAR ±1/2°
 DRAFT WHERE APPLICABLE
 MUST REMAIN WITHIN DIMENSIONS

DIMENSION STYLE
MM ONLY
 DRAWN BY JSCHAFFER DATE 2011/11/07
 CHECKED BY DATE SIX SEGMENT
 APPROVED BY APATEL DATE 2014/08/25
 MATERIAL NO. 9999999999
 SIZE B

SCALE 1.5:1
 DESIGN UNITS METRIC
 THIRD ANGLE PROJECTION
 TITLE POWER EDGE ASSEMBLY
 POWER / SIGNAL MIXED
 RT ANGLE SOLDER TAIL
 PARTS
 MOLEX INCORPORATED
 DOCUMENT NO. SD-45911-002
 SHEET NO. 5 OF 5
 THIS DRAWING CONTAINS INFORMATION THAT IS PROPRIETARY TO MOLEX INCORPORATED AND SHOULD NOT BE USED WITHOUT WRITTEN PERMISSION