

| MATERIAL NUMBER | FINISH | HOLE     |
|-----------------|--------|----------|
| 43178-2001      | 999    | NOT USED |
| 43178-2002      | H901   | NOT USED |
| 43178-2003      | F542   | NOT USED |

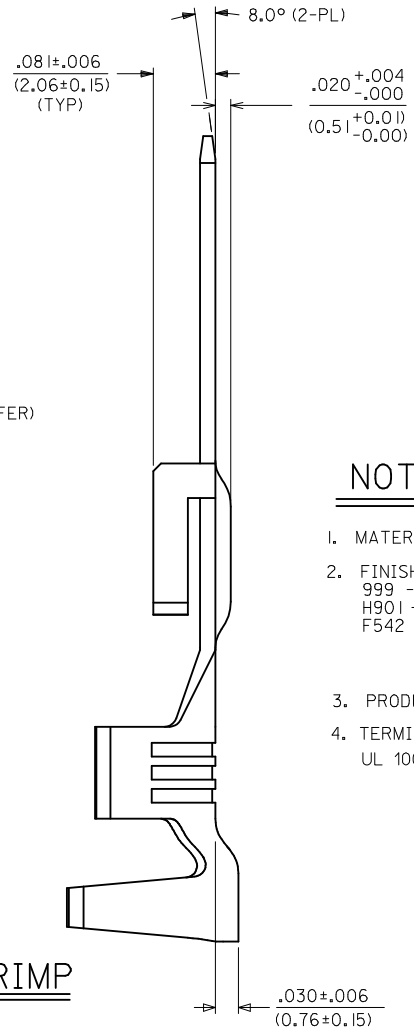

**NOTES**

- MATERIAL: BRASS
- FINISH:  
999 - UNPLATED  
H901 - 20 MICROINCH MIN. HOT TIN DIP  
F542 - 15 MICROINCH MIN. SELECT GOLD IN CONTACT AREA,  
50 MICROINCH TIN-LEAD IN CRIMP AREA,  
NICKEL UNDERPLATE OVERALL.
- PRODUCT SPECIFICATION : PS-44441-001
- TERMINAL FOR USE WITH SINGLE 14-16 AWG OR DOUBLE 18+20 AWG.  
UL 1007 OR 1015 STYLE WIRE.

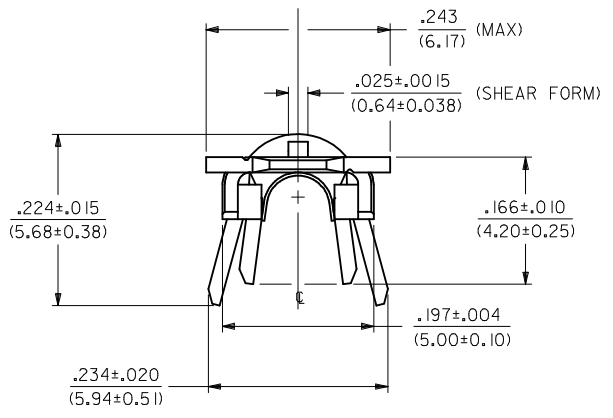
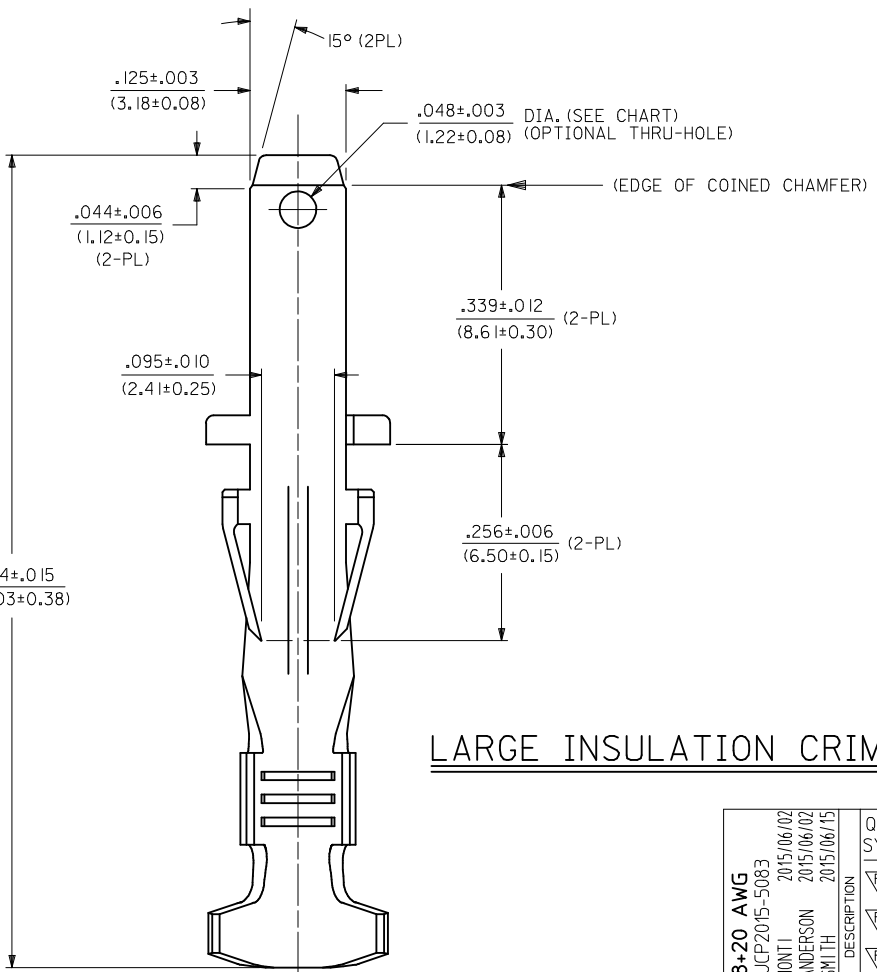

**LARGE INSULATION CRIMP**

|   |                                      |  |                       |                          |                      |                     |                       |                        |  |  |  |
|---|--------------------------------------|--|-----------------------|--------------------------|----------------------|---------------------|-----------------------|------------------------|--|--|--|
| ADD 18+20 AWG<br>EC NO: UCP2015-5083<br>DRWN: MONTI 2015/06/02<br>CHKD: BANDERSON 2015/06/02<br>APPR: FSMITH 2015/06/15 | QUALITY SYMBOLS<br>∇=0<br>∇=0<br>∇=0 | GENERAL TOLERANCES (UNLESS SPECIFIED)                |                       | DIMENSION STYLE<br>IN/MM |                      | SCALE<br>8:1        | DESIGN UNITS<br>INCH  | THIRD ANGLE PROJECTION |  |  |  |
|   |                                      | 4 PLACES ± --- ± ---                                 | 3 PLACES ± --- ± .010 | 2 PLACES ± 0.25 ± .014   | 1 PLACE ± 0.35 ± --- | 0 PLACE ± --- ± --- | DRAWN BY<br>KBP       | DATE<br>1995/06/19     | TITLE<br>TERMINAL, CRIMP MALE TAB<br>.125/(3.18)X.020/(0.51)<br>SABRE - F.B.S. - TPA |  |  |
|   |                                      | ANGULAR ±1/2°  |                       |                          |                      |                     | CHECKED BY<br>KBP     | DATE<br>1995/06/19     | DOCUMENT NO.<br>SD-43178-2***  |  |  |
|   |                                      | DRAFT WHERE APPLICABLE MUST REMAIN WITHIN DIMENSIONS |                       |                          |                      |                     | APPROVED BY<br>FSMITH | DATE<br>2015/06/15     | SHEET NO.<br>1 OF 1  |  |  |