

RECOMMENDED PLATED THRU HOLE PATTERN  
SCALE 2:1

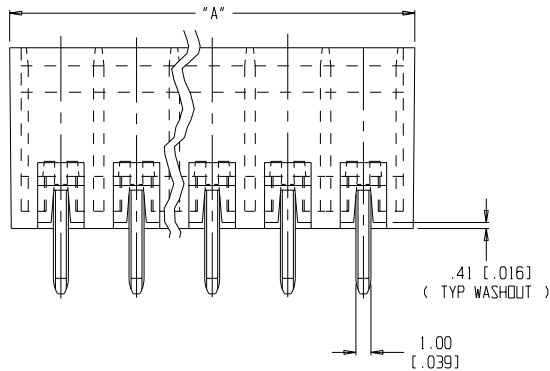
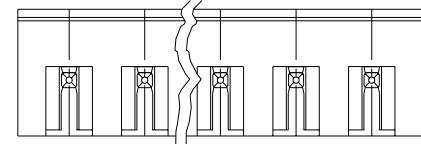
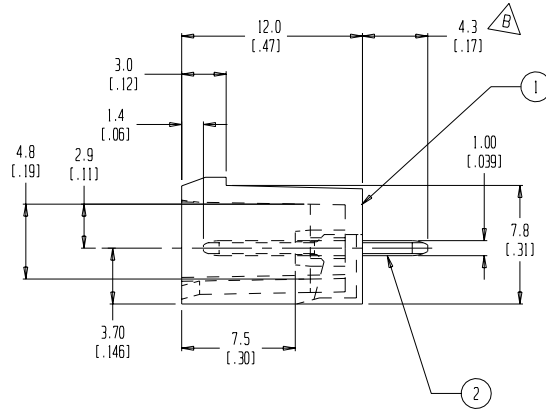
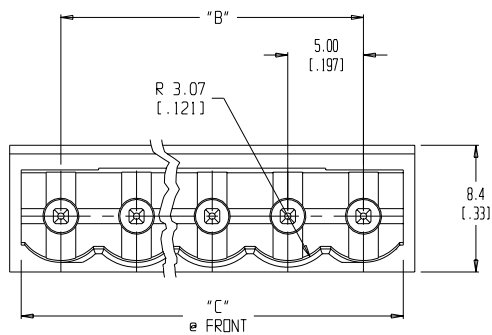

NOTES:

1. MATERIAL: SEE TABLE
2. FINISHES: SEE TABLE
3. PRODUCT SPECIFICATION: NOT REQUIRED
4. PACKAGING: NOT REQUIRED
5. MATES WITH: 87 SERIES PLUG
6. "XX" REFERS TO THE NUMBER OF CIRCUIT POSITIONS.
7. FOR 10A AND 11A IMPRINTING SEE DRAWING SD-38120-003.
8. DIMENSIONS IN BRACKETS ARE INCHES.

ITEM	QTY.	DESCRIPTION	MATERIAL	FINISH
2	XX	STRAIGHT HEADER PIN	BRASS	TIN PLATED GOLD PLATED
1	1	BASE MOLDING	THERMOPLASTIC	SEE CHART

EC NO. 11452 DRWN: RK 10-2-03 CHK: [ ] APPR: [ ]	QUALITY SYMBOLS MAJOR $\blacktriangledown$ = CRITICAL $\nabla$ = SPC $\triangle$ = S =	GENERAL TOLERANCES: (UNLESS SPECIFIED)		SCALE 4:1	DESIGN UNITS <input type="checkbox"/> mm <input checked="" type="checkbox"/> INCH	THIRD ANGLE PROJECTION 	PROJECT NO. - DIMENSIONS: <input checked="" type="checkbox"/> mm <input type="checkbox"/> INCH <input type="checkbox"/> mm ONLY	- SHT REV - REV
		4 PLACES ±.0015 3 PLACES ±.038 ±.005 2 PLACES ±.13 ±.01 1 PLACE ±.3		DRAWN BY & DATE W. HOWARD 08-20-03	TITLE: HEADER ST, CLOSED ENDS, ASSY. (5.00 [.197] CENTERS)			
		ANGULAR: ±2°		CHECKED BY & DATE R. KEMP 08-28-03	MOLEX INCORPORATED			
		DRAFT WHERE APPLICABLE MUST REMAIN WITHIN DIMENSIONS		APPROVED BY & DATE P. WALTZ 09-02-03	CAD FILENAME 8716XX01	MATERIAL NO. -	DRAWING NO. SD-39870-006	SHEET NO. 1 OF 2

THIS DRAWING CONTAINS INFORMATION THAT IS PROPRIETARY TO MOLEX INCORPORATED AND SHOULD NOT BE USED WITHOUT WRITTEN PERMISSION.

BLACK (STD) MATERIAL NO.	BLACK (-G30 OPT) MATERIAL NO.	10A IMPRINT MATERIAL NO.	11A IMPRINT MATERIAL NO.	NUMBER OF CIRCUITS "XX"	DIM. "A" ±.38 [.015]	DIM. "B"	DIM. "C" ±.33 [.012]
398700502	398710502	398720502	398730502	02	11.30 [.445]	5.00 [.197]	10.34 [.407]
398700503	398710503	398720503	398730503	03	16.31 [.642]	10.01 [.394]	15.34 [.604]
398700504	398710504	398720504	398730504	04	21.31 [.839]	15.01 [.591]	20.35 [.801]
398700505	398710505	398720505	398730505	05	26.31 [1.036]	20.02 [.788]	25.35 [.998]
398700506	398710506	398720506	398730506	06	31.32 [1.233]	25.02 [.985]	30.35 [1.195]
398700507	398710507	398720507	398730507	07	36.93 [1.454]	30.02 [1.182]	35.36 [1.392]
398700508	398710508	398720508	398730508	08	41.94 [1.651]	35.03 [1.379]	40.36 [1.589]
398700509	398710509	398720509	398730509	09	46.94 [1.848]	40.03 [1.576]	45.36 [1.786]
398700510	398710510	398720510	398730510	10	51.94 [2.045]	45.03 [1.773]	50.37 [1.983]
398700511	398710511	398720511	398730511	11	56.95 [2.242]	50.04 [1.970]	55.37 [2.180]
398700512	398710512	398720512	398730512	12	61.95 [2.439]	55.04 [2.167]	60.38 [2.377]
398700513	398710513	398720513	398730513	13	66.95 [2.636]	60.05 [2.364]	65.38 [2.574]
398700514	398710514	398720514	398730514	14	71.96 [2.833]	65.05 [2.561]	70.38 [2.771]
398700515	398710515	398720515	398730515	15	76.96 [3.030]	70.31 [2.768]	75.39 [2.968]
398700516	398710516	398720516	398730516	16	81.97 [3.227]	75.06 [2.955]	80.39 [3.165]
398700517	398710517	398720517	398730517	17	86.97 [3.424]	80.06 [3.152]	85.39 [3.362]
398700518	398710518	398720518	398730518	18	91.97 [3.621]	85.06 [3.349]	90.40 [3.559]
398700519	398710519	398720519	398730519	19	96.98 [3.818]	90.07 [3.546]	95.40 [3.756]
398700520	398710520	398720520	398730520	20	101.98 [4.015]	95.07 [3.743]	100.41 [3.953]
398700521	398710521	398720521	398730521	21	106.98 [4.212]	100.08 [3.940]	105.41 [4.150]
398700522	398710522	398720522	398730522	22	111.99 [4.409]	105.08 [4.137]	110.41 [4.347]
398700523	398710523	398720523	398730523	23	116.99 [4.606]	110.08 [4.334]	115.42 [4.544]
398700524	398710524	398720524	398730524	24	122.00 [4.803]	115.09 [4.531]	120.42 [4.741]

EC NO. SEE PAGE ONE	QUALITY SYMBOLS MAJOR = CRITICAL = SPC = S =	GENERAL TOLERANCES: (UNLESS SPECIFIED)		SCALE -	DESIGN UNITS <input type="checkbox"/> mm <input checked="" type="checkbox"/> INCH	THIRD ANGLE PROJECTION	PROJECT NO. -	-	-
		4 PLACES	mm	INCH	±.0015		DRAWN BY & DATE W. HOWARD 08-20-03	TITLE: HEADER ST, CLOSED ENDS, ASSY. (5.00 [.197] CENTERS)	DIMENSIONS: <input checked="" type="checkbox"/> mm <input type="checkbox"/> INCH <input type="checkbox"/> mm ONLY
-	REV	3 PLACES	±.038	±.005	CHECKED BY & DATE	APPROVED BY & DATE	REVISE ON CAD ONLY		
		2 PLACES	±.13	±.01	APPROVED BY & DATE		MATERIAL NO. -		
		1 PLACE	±.3		CAD FILENAME 8716XX01	DRAWING NO. SD-39870-006	SHEET NO. 2 OF 2		
		ANGULAR: ±2°		DRAFT WHERE APPLICABLE MUST REMAIN WITHIN DIMENSIONS		THIS DRAWING CONTAINS INFORMATION THAT IS PROPRIETARY TO MOLEX INCORPORATED AND SHOULD NOT BE USED WITHOUT WRITTEN PERMISSION.			
								SIZE C	