

2 AND 3 CIRCUIT PARTS HAVE ONE LATCH DETAIL POSITIONED ON THIS END.

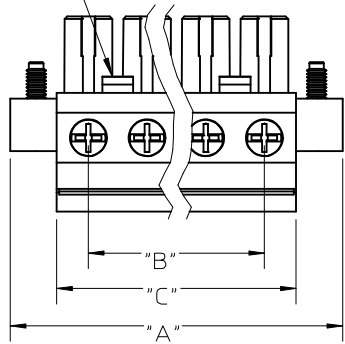

NO. OF CIRC.	STD. MAT. NUMBER	OPTIONAL 10A IMPRINT	"A" IN/MM	"B" IN/MM	"C" IN/MM	"D" IN/MM
02	394220002	394222002	1.73/44.0	.472/12.00	.98/25.0	1.313/33.35
03	394220003	394222003	2.20/56.0	.945/24.00	1.46/37.0	1.785/45.35
04	394220004	394222004	2.68/68.0	1.417/36.00	1.93/49.0	2.258/57.35
05	394220005	394222005	3.15/80.0	1.890/48.00	2.40/61.0	2.730/69.35
06	394220006	394222006	3.62/92.0	2.362/60.00	2.87/73.0	3.203/81.35
07	394220007	394222007	4.09/104.0	2.835/72.00	3.35/85.0	3.675/93.35
08	394220008	394222008	4.57/116.0	3.307/84.00	3.82/97.0	4.148/105.35

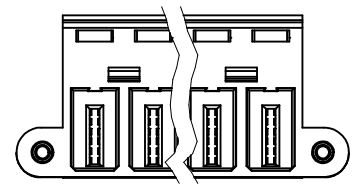
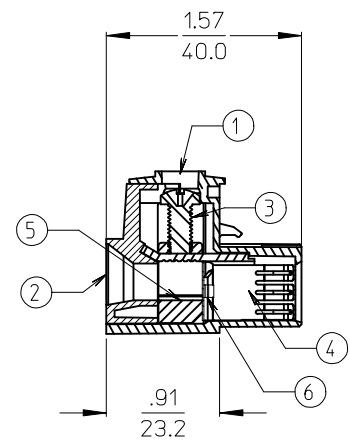
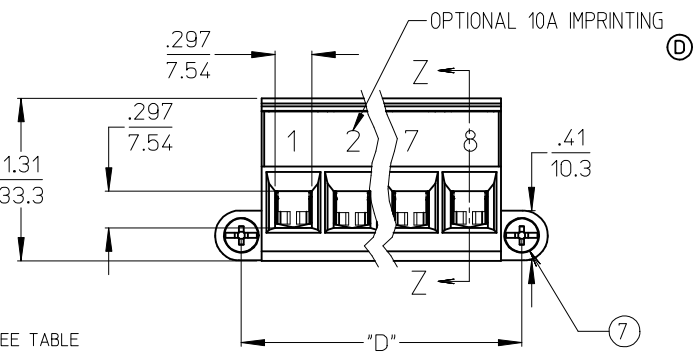
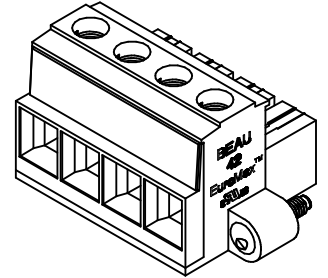

- NOTES:
1. MATERIAL: SEE TABLE
  2. FINISHES: SEE TABLE
  3. PRODUCT SPECIFICATION: SEE PPS.42.002
  4. IMPRINTING CHARACTER HEIGHT IS .170" Ⓣ
  5. ROHS COMPLIANT BY EXEMPTION \*

ITEM	QTY.	DESCRIPTION	MATERIAL	FINISH
7	2	SCREW, MTG. END, M4, PHIL-SLOT	PHOS. BRONZE	TIN PLATE
6	XX	BACK PLATE	PHOS. BRONZE	TIN PLATE
5	XX	PRESSURE CLAMP *	BRASS	NICKEL PLATE
4	XX	TERMINAL	COPPER ALLOY	TIN PLATE
3	XX	SCREW, M5 PAN HEAD, POZI-SLOT	STAINLESS STEEL	TIN PLATE
2	1	MOLDING COVER	POLYESTER (PBT)	BLACK
1	1	MOLDING, BODY, WITH MTG ENDS	POLYESTER (PBT)	BLACK

**ADD 10A OPTION**

EC NO: WNA2009-0615  
 DRWN: JENCINAS 2009/04/09  
 CHKD: CYORK 2009/04/09  
 APPR: JMAGNELL 2009/04/13

QUALITY SYMBOLS  
 ▽=0  
 ▽=0

GENERAL TOLERANCES (UNLESS SPECIFIED)

	mm	INCH
4 PLACES	± ---	± ---
3 PLACES	± ---	± .005
2 PLACES	± 0.13	± .01
1 PLACE	± 0.3	± ---

ANGULAR ±1/2°

DRAFT WHERE APPLICABLE MUST REMAIN WITHIN DIMENSIONS

DIMENSION STYLE  
IN/MM

DRAWN BY	DATE
RKEMP	04/10/13
CHECKED BY	DATE
RSTONE	04/12/07
APPROVED BY	DATE
G. ROBERTSON	04/12/10

MATERIAL NO.

SCALE 4:1

DESIGN UNITS INCH

THIRD ANGLE PROJECTION

TITLE  
**PLUG, MTG. ENDS  
 12MM, 85A, 600V  
 #10-#3 AWG**

**molex** MOLEX INCORPORATED

DOCUMENT NO. SD-39422-001

SHEET NO. 1 OF 1