

| PART NO.  | LENGTH                     |
|-----------|----------------------------|
| 847320001 | 0.8M (31.50") +1.0"/-0.0"  |
| 847320002 | 1.5M (59.06") +1.5"/-0.0"  |
| 847320003 | 2.0M (78.74") +1.5"/-0.0"  |
| 847320004 | 3.0M (118.11") +1.5"/-0.0" |
| 847320005 | 5.0M (196.85") +2.0"/-0.0" |

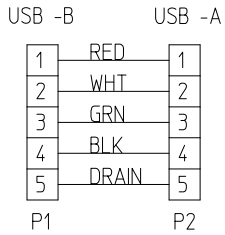

WIRING DIAGRAM

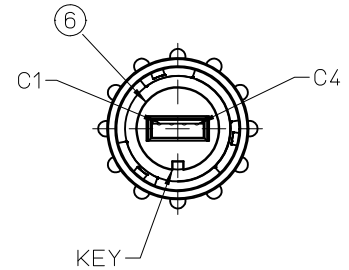
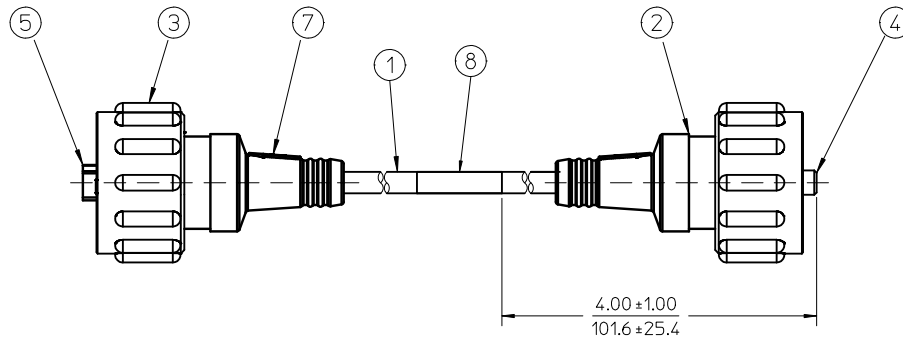
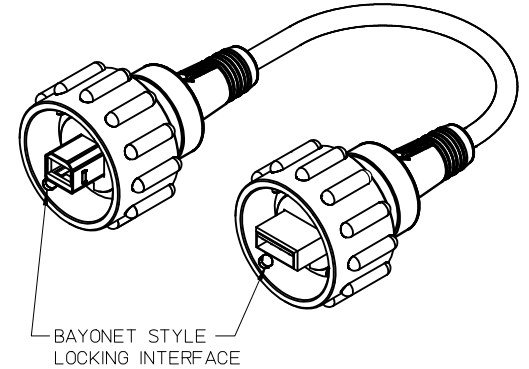
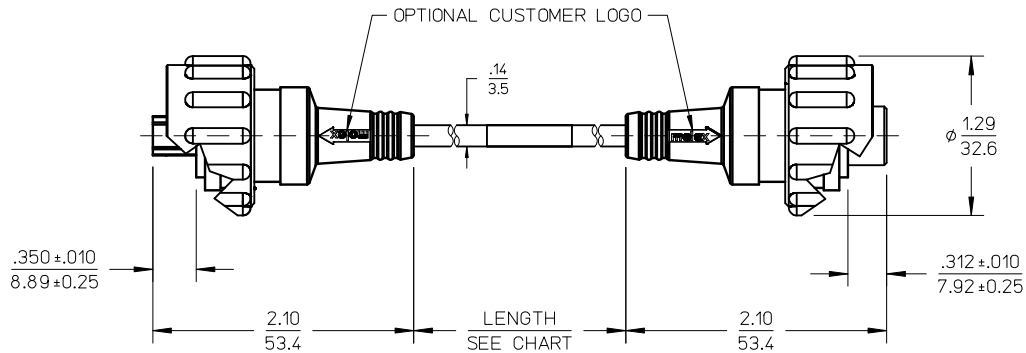

NOTES: UNLESS OTHERWISE SPECIFIED

1. MATERIAL: SEE TABLE.
2. FINISH: SEE TABLE.
3. PRODUCT SPECIFICATION: SEE SPECIFICATION.
4. PACKAGING: AS REQUIRED.
5. MATES WITH BAYONET STYLE USB A & B BAYONET LOCKING RECEPTACLES.
6. ASSEMBLY IS RoHS COMPLIANT.

|      |      |                                    |              |              |
|------|------|------------------------------------|--------------|--------------|
| 8    | 1    | WRAP LABEL                         | PLASTIC FILM | BLACK/YELLOW |
| 7    | 2    | OVERMOLD                           | PVC          | BLACK        |
| 6    | 2    | GASKET SEAL                        | NITRILE      | BLACK        |
| 5    | 1    | USB TYPE -B SHIELDED PLUG          | -            | -            |
| 4    | 1    | USB TYPE -A SHIELDED PLUG          | -            | -            |
| 3    | 2    | COUPLING RING                      | POLYESTER    | BLACK        |
| 2    | 2    | HOLDERS USB A-B                    | POLYESTER    | BLACK        |
| 1    | 1    | CABLE 4/C, 28AWG, SHIELD/DRAIN USB | -            | BLACK        |
| ITEM | QTY. | DESCRIPTION                        | MATERIAL NO. | FINISH       |

|  |                 |
|--|-----------------|
| <b>ADD WRAP LABEL</b><br>EC NO: WNA2010-0206<br>DRAWN: YOU 2009/10/19<br>CHKD: RSTONE 2009/12/15<br>APPR: JFURPHY 2009/12/15 | QUALITY SYMBOLS |
|  | ▼=0<br>▽=0      |
|  | DESCRIPTION     |
|  | REV             |

| GENERAL TOLERANCES (UNLESS SPECIFIED) |        |
|---------------------------------------|--------|
| mm                                    | INCH   |
| 4 PLACES ± ---                        | ± ---  |
| 3 PLACES ± ---                        | ± .005 |
| 2 PLACES ± 0.13                       | ± .01  |
| 1 PLACE ± 0.3                         | ± ---  |
| ANGULAR ± 2 °                         |        |

DRAFT WHERE APPLICABLE  
MUST REMAIN WITHIN DIMENSIONS

| DIMENSION STYLE |              |
|-----------------|--------------|
| IN/MM           |              |
| DRAWN BY        | DATE         |
| S.GILBERT       | 11-30-04     |
| CHECKED BY      | DATE         |
| APPROVED BY     | DATE         |
| JFMURPHY        | 2009/12/15   |
| MATERIAL NO.    | DOCUMENT NO. |
| SEE CHART       | SD-84732-001 |

| SCALE   | DESIGN UNITS | THIRD ANGLE PROJECTION |
|---|--------------|------------------------|
| 1:1   | INCH         |                        |
| <b>USB DUAL PLUG TYPE A &amp; B<br/>COUPLER SHIELDED CABLE<br/>CIC, DE EXT CORD</b> |              |                        |
| <b>MOLEX INCORPORATED</b>   |              | SHEET NO.<br>1 OF 1    |

THIS DRAWING CONTAINS INFORMATION THAT IS PROPRIETARY TO MOLEX INCORPORATED AND SHOULD NOT BE USED WITHOUT WRITTEN PERMISSION