

4.25GBPS 850NM PIN + PREAMP LC ROSA PACKAGE

HFD3180-203

FEATURES:

- LC ROSA
- High performance GaAs PIN photodiode with separate transimpedance amplifier
- Low electrical parasitic TO46 package
- Data rates from 155Mbps to 4.25Gbps
- A separate detector bias pin which can be used for receive power monitoring
- Low bias currents and voltages

The HFD3180-203 use a high-performance GaAs PIN photo-detector packaged with a transimpedance amplifier designed to meet performance requirements for data rates up to 4.25Gbps data communication over multi-mode optical fiber at 850nm. Applications include Ethernet, Fiber Channel and ATM protocols. The optical assembly is designed to interface either 50 μ m or 62.5 μ m multi-mode fiber.

The HFD3180-203 is designed to be paired with Advanced Optical Components VCSEL TOSA products (see data sheets for HFE419x products).



Part Number	Description
HFD3180-203	5 pin LC ROSA, with separate PD bias for RSSI

ABSOLUTE MAXIMUM RATINGS

Parameter	Rating
Storage temperature	-40°C to +85°C
Case Operating	-40°C to +85°C
Lead solder temperature	260°C, 10 seconds
Power Supply Voltage	-0.5V to 4V
Incident Optical Power	+3 dBm average, +6 dBm

NOTICE: Stresses greater than those listed under “Absolute Maximum Ratings” may cause permanent damage to the device. This is a stress rating only and functional operation of the device at these or any other conditions above those indicated in the operations section for extended periods of time may affect reliability.

NOTICE: The inherent design of this component causes it to be sensitive to electrostatic discharge (ESD). To prevent ESD-induced damage and/or degradation to equipment, take normal ESD precautions when handling this product

ELECTRO-OPTICAL CHARACTERISTICS

Parameters	Test Condition	Symbol	Min.	Typ.	Max.	Units	Notes
Data Rate		DR	0.15		4.25	Gbps	
Supply Voltage			3.0	3.3	3.6	V	
Supply Current	$P_R = 0\mu W$, $R_L = 50\Omega$ AC coupled	I_{CC}		30	45	mA	1
Optical Return Loss	$P_R = -12\text{dBm}$	ORL	12			dB	1
Input Optical Wavelength	0°C to 70°C	λ_P	770	850	870	nm	
Maximum Average Input Power before Overload		P_{MAX}	0	+3		dBm	
Differential Output Voltage Swing	$P_{R,OMA} = -12\text{Bm}$, AC Coupled to $R_L = 50\Omega$	$V_{o(pk-pk)}$	100	150	220	mV	1,2
Differential Transimpedance	$P_{R,OMA} = -12\text{dBm}$, AC Coupled to $R_L = 50\Omega$	T	1500	2500	3500	V/W	1,2
-3dB Optical/Electrical Bandwidth	$P_{R,OMA} = -12\text{dBm}$	BW	2		4	GHz	1,2,3
Low Frequency -3dB Cutoff	$P_{R,OMA} = -12\text{dBm}$	BW_{LF}			10	KHz	1,2,3
Output Impedance		Z_{OUT}	42	50	58	Ω	
Output Return Loss	$F < 3\text{GHz}$	S_{22}	8	12		dB	
RMS Input Referred Noise Equivalent Power	3.2GHz, 4 -pole BT Filter, $P_R = 0\mu W$ (Dark), BER 10^{-12}	NEP			20	μW , OMA	4
Sensitivity, OMA	DR = 1.0625, 1.25Gbps	S		-20	-17	dBm	5
	DR = 2.125, 2.5Gbps			-19	-16		
	DR = 3.125Gbps			-18	-16		
	DR = 4.25Gbps			-18	-15.5		
Stressed Sensitivity, OMA	DR = 1.0625, 1.25Gbps	$S_{Stressed}$		-17	-14	dBm	5,6
	DR = 2.125, 2.5Gbps			-16	-13		
	DR = 3.125Gbps			-14	-11		
	DR = 4.25Gbps			-14	-10.5		
Rise/Fall Time	$P_{R,OMA} = -12\text{dBm}$, (20%-80%)	T_R/T_F		80	120	ps	2,7
Pulse Width Distortion		PWD			5	%	
Power Supply Rejection Ratio	$P_R = 0\mu W$ (Dark), $5\text{MHz} < F < 2\text{GHz}$	PSRR	20			dB	1,8
Monitor Current Slope	$P_R = -12\text{dBm}$	I_{MON}	0.45	0.5	0.55	A/W	9
Monitor Current Offset	$P_R = 0\text{mW}$	I_{OFFSET}			10	nA	
PD Bias Voltage		PD_{BIAS}	$V_{CC}-1$	V_{CC}	$V_{CC}+0.5$	V	13
Group Delay	$P_{R,OMA} = -12\text{dBm}$, AC Coupled to $R_L = 50\Omega$ $2\text{MHz} < F < 2\text{GHz}$	Delay	-50		50	ps	10
Deterministic Jitter	$P_{R,OMA} = -12\text{dBm}$, AC Coupled to $R_L = 50\Omega$	DJ_{TIA}		30	40	ps	11
Random Jitter	$P_{R,OMA} = -12\text{dBm}$, AC Coupled to $R_L = 50\Omega$	RJ_{TIA}		3	5	ps	12

3.0V < V_{CC} < 3.6V, AC coupled to 50 Ω (100 Ω differential), -40°C < T < 85°C unless otherwise specified

NOTES

- P_R is the average optical power at the fiber face.
- $P_{R,OMA}$ is the peak to peak optical power at the fiber face (Optical Modulation Amplitude)

$$P_{R,OMA} \equiv \frac{2P_R(ER-1)}{ER+1}$$
 where ER is the extinction ratio (linear) of the optical source.
- Bandwidth and Low Frequency Cutoff are measured with a small signal sinusoidal light source with -12dBm average power
- RMS input referred optical noise equivalent power is obtained by measuring the RMS output noise into a 1875 MHz, 4-pole Bessel-Thompson filter then dividing by the responsivity. A scaling factor of 14 is used to predict a BER of 10^{-12} .
- Sensitivity is measured with an optical source with an extinction ratio of 3dB.
- Stressed receiver sensitivity is measured with 3.5dB vertical eye closure (intersymbol interference) and with 0.3UI of jitter added. The measurement technique is defined in IEEE 802.3ae.
- Rise/Fall times are corrected for optical source Rise/Fall times. $T_{TIA}^2 = T_{MEASURED}^2 - T_{OPTICAL}^2$
- Value shown is with no external power supply filtering.
- The monitor current slope is measured as the current into the PD_{BIAS} connection.
- Group delay is a sensitive measurement to package interface, and includes the effects of PD, TIA and package. Measurement is made with TO leads as short as possible.
- DJ_{TIA} is specified as contributed DJ by the TIA, obtained from $DJ_{TIA}^2 = DJ_{TOTAL}^2 - DJ_{OPTICAL}^2$
- RJ_{TIA} is specified as contributed DJ by the TIA, obtained from $RJ_{TIA}^2 = RJ_{TOTAL}^2 - RJ_{OPTICAL}^2$
- If external bias voltage is applied to V_{PD} while V_{CC} is externally unbiased, internal biasing of the TIA will occur, resulting in erroneous RSSI current.

PINOUT

HFD3180-203	
Number	Function
1	OUP
2	OUTN
3	V_{PD}
4	V_{CC}
5	GND (Case)

INTERFACE CONFIGURATION

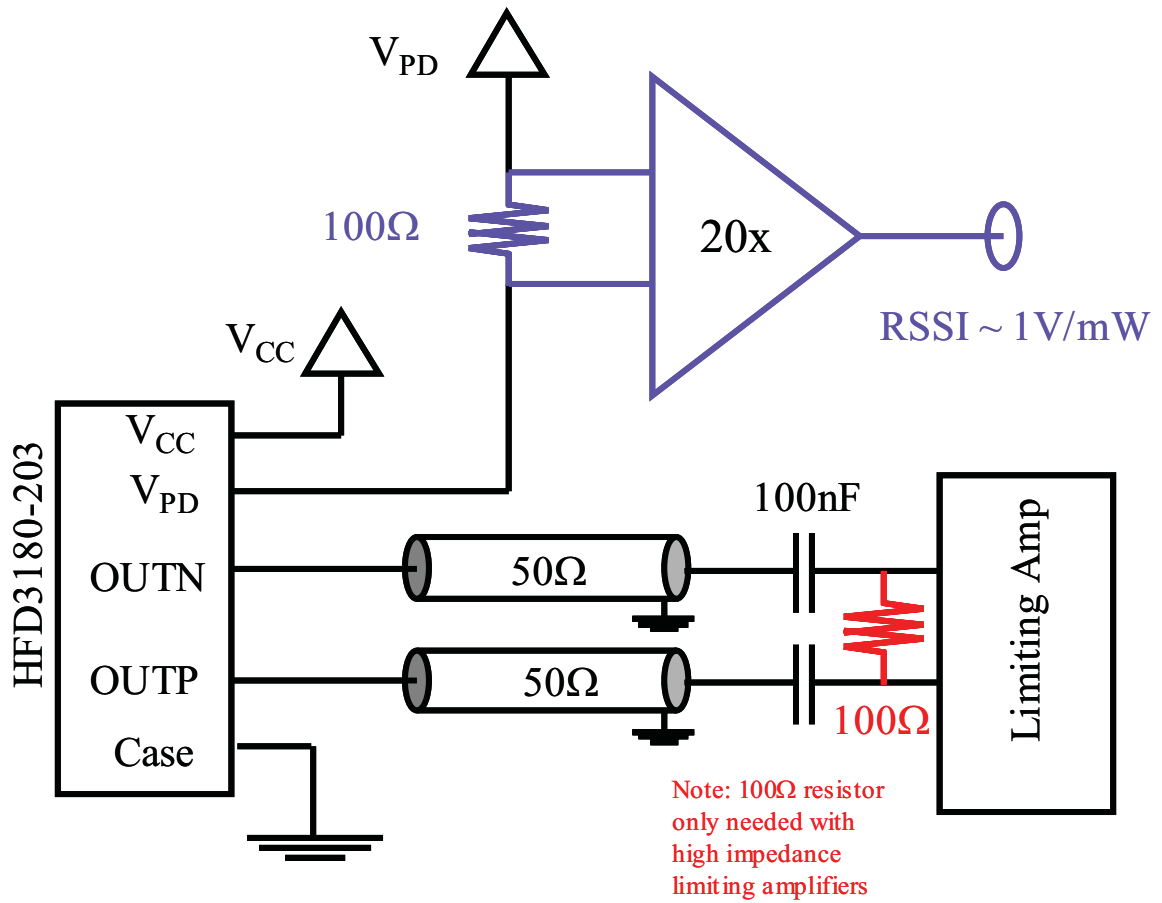

Optional RSSI implementation is shown in blue

Optional 100Ω differential termination for high impedance limiting amplifiers is shown in red.

Recommended bias filter network

Note, better performance will be obtained if a ferrite bead is used in place of the inductor.

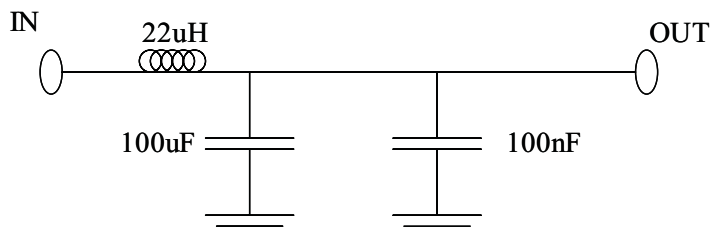

MECHANICAL DIMENSIONS

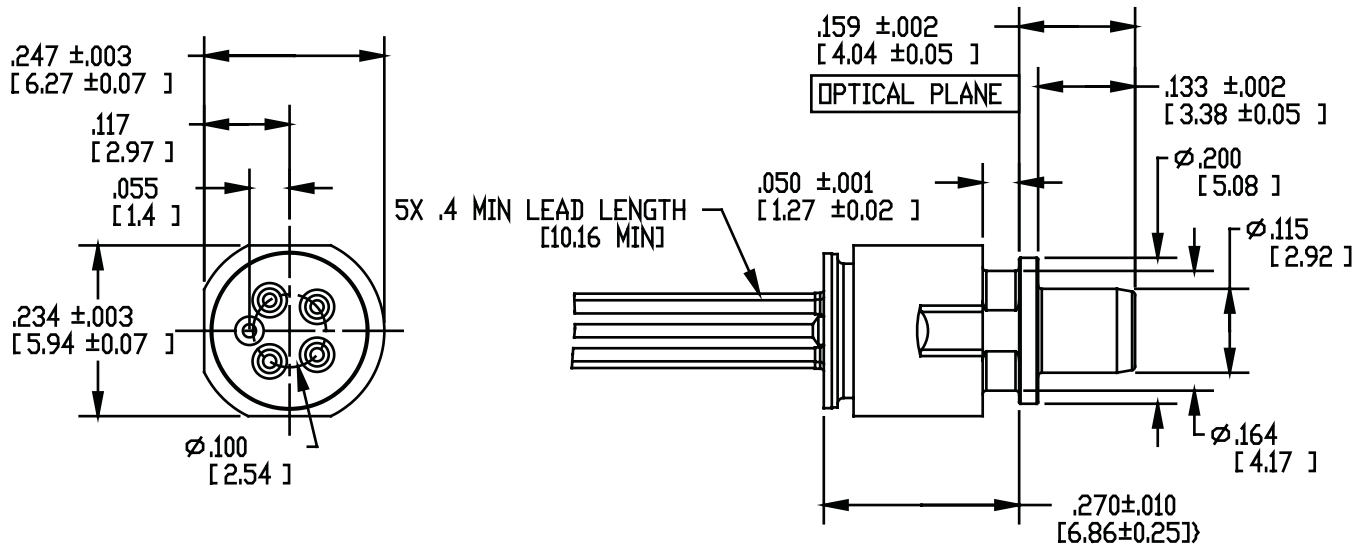

PIN #	FUNCTION
1	V _{OUT+}
2	V _{OUT-}
3	V _{PD}
4	V _{CC}
5	GND (CASE)

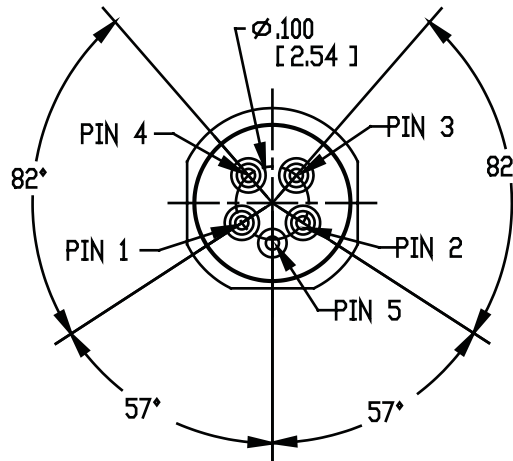

ADVANCED OPTICAL COMPONENTS

Finisar's ADVANCED OPTICAL COMPONENTS division was formed through strategic acquisition of key optical component suppliers. The company has led the industry in high volume Vertical Cavity Surface Emitting Laser (VCSEL) and associated detector technology since 1996. VCSELs have become the primary laser source for optical data communication, and are rapidly expanding into a wide variety of sensor applications. VCSELs' superior reliability, low drive current, high coupled power, narrow and circularly symmetric beam and versatile packaging options (including arrays) are enabling solutions not possible with other optical technologies. ADVANCED OPTICAL COMPONENTS is also a key supplier of Fabry-Perot (FP) and Distributed Feedback (DFB) Lasers, and Optical Isolators (OI) for use in single mode fiber data and telecommunications networks

LOCATION

- Allen, TX - Business unit headquarters, VCSEL wafer growth, wafer fabrication and TO package assembly.
- Fremont, CA – Wafer growth and fabrication of 1310 to 1550nm FP and DFB lasers.
- Shanghai, PRC – Optical passives assembly, including optical isolators and splitters.

SALES AND SERVICE

Finisar's ADVANCED OPTICAL COMPONENTS division serves its customers through a worldwide network of sales offices and distributors. For application assistance, current specifications, pricing or name of the nearest Authorized Distributor, contact a nearby sales office or call the number listed below.

Finisar
Advanced Optical Components Division

Phone: 1-866-MY-VCSEL USA (toll free)
1-214-509-2700 USA (Direct dial)
44 (0) 174 336 5533 Europe
886-935-409898 China & Taiwan
81-90-4437-1130 Japan
82-11-220-6153 Asia Pacific & Korea

Fax: 1-214-509-3709 USA

Email: support@adopco.com
WEB: www.finisar.com/aoc.php

AOC CAPABILITIES

ADVANCED OPTICAL COMPONENTS' advanced capabilities include:

- 1, 2, 4, 8, and 10Gbps serial VCSEL solutions
- 1, 2, 4, 8, and 10Gbps serial SW DETECTOR solutions
- VCSEL and detector arrays
- 1, 2, 4, 8, and 10Gbps FP and DFB solutions at 1310 and 1550nm
- 1, 2, 4, 8, and 10Gbps serial LW DETECTOR solutions
- Optical Isolators from 1260 to 1600nm range
- Laser packaging in TO46, TO56, and Optical subassemblies with SC, LC, and MU interfaces for communication networks
- VCSELs operating at 670nm, 780nm, 980nm, and 1310nm in development
- Sensor packages include surface mount, various plastics, chip on board, chip scale packages, etc.
- Custom packaging options