

## Product Specification

### 2 Gb/s RoHS Compliant Long-Wavelength Pluggable SFP Transceiver

### FTLF1519P1xNL

#### PRODUCT FEATURES

- Up to 2.125Gb/s bi-directional data links
- Hot-pluggable SFP footprint
- Built-in digital diagnostic functions
- Uncooled 1550nm DFB laser transmitter
- Duplex LC connector
- RoHS compliant and Lead Free
- Metal enclosure, for lower EMI
- Single 3.3V power supply
- Up to 80 km on 9/125µm SMF
- Low power dissipation typically <700mW
- Extended operating temperature range: -5°C to 85°C



#### APPLICATIONS

- Gigabit Ethernet
- 1X and 2X Fibre Channel

Finisar's FTLF1519P1xNL Small Form Factor Pluggable (SFP) transceivers are compatible with the Small Form Factor Pluggable Multi-Sourcing Agreement (MSA)<sup>1</sup>. They simultaneously comply with Gigabit Ethernet as specified in IEEE Std 802.3<sup>2</sup>, and 1x and 2x Fibre Channel as defined in FC-PI 13.0<sup>3,4</sup>. They are RoHS compliant and lead-free per Directive 2002/95/EC<sup>5</sup> and Finisar Application Note AN-2038. Digital diagnostics functions are available via the 2-wire serial bus specified in the SFP MSA.

#### PRODUCT SELECTION

### FTLF1519P1xNL

x	W	Wide Extraction Bail
	B	Narrow Extraction Bail

**I. Pin Descriptions**

Pin	Symbol	Name/Description	Ref.
1	V <sub>EET</sub>	Transmitter Ground (Common with Receiver Ground)	1
2	T <sub>FAULT</sub>	Transmitter Fault. Not supported.	
3	T <sub>DIS</sub>	Transmitter Disable. Laser output disabled on high or open.	2
4	MOD_DEF(2)	Module Definition 2. Data line for Serial ID.	3
5	MOD_DEF(1)	Module Definition 1. Clock line for Serial ID.	3
6	MOD_DEF(0)	Module Definition 0. Grounded within the module.	3
7	Rate Select	No connection required	4
8	LOS	Loss of Signal indication. Logic 0 indicates normal operation.	5
9	V <sub>EER</sub>	Receiver Ground (Common with Transmitter Ground)	1
10	V <sub>EER</sub>	Receiver Ground (Common with Transmitter Ground)	1
11	V <sub>EER</sub>	Receiver Ground (Common with Transmitter Ground)	1
12	RD-	Receiver Inverted DATA out. AC Coupled	
13	RD+	Receiver Non-inverted DATA out. AC Coupled	
14	V <sub>EER</sub>	Receiver Ground (Common with Transmitter Ground)	1
15	V <sub>CCR</sub>	Receiver Power Supply	
16	V <sub>CCT</sub>	Transmitter Power Supply	
17	V <sub>EET</sub>	Transmitter Ground (Common with Receiver Ground)	1
18	TD+	Transmitter Non-Inverted DATA in. AC Coupled.	
19	TD-	Transmitter Inverted DATA in. AC Coupled.	
20	V <sub>EET</sub>	Transmitter Ground (Common with Receiver Ground)	1

Notes:

1. Circuit ground is internally isolated from chassis ground.
2. Laser output disabled on T<sub>DIS</sub> >2.0V or open, enabled on T<sub>DIS</sub> <0.8V.
3. Should be pulled up with 4.7k - 10 kohms on host board to a voltage between 2.0V and 3.6V. MOD\_DEF(0) pulls line low to indicate module is plugged in.
4. Finisar FTLFxx19xxxxx transceivers operate at 1x and 2x Fibre Channel, and Gigabit Ethernet data rates and respective protocols without active control.
5. LOS is open collector output. Should be pulled up with 4.7k – 10 kohms on host board to a voltage between 2.0V and 3.6V. Logic 0 indicates normal operation; logic 1 indicates loss of signal.

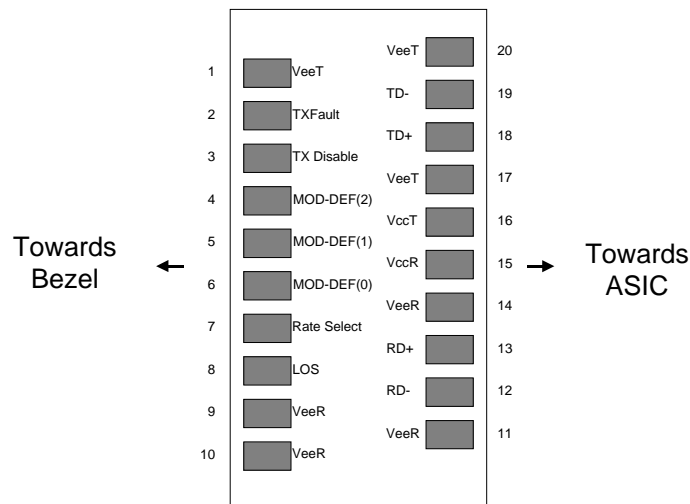

**Pinout of Connector Block on Host Board**

**II. Absolute Maximum Ratings**

Parameter	Symbol	Min	Typ	Max	Unit	Ref.
Maximum Supply Voltage	V <sub>CC</sub>	-0.5		4.5	V	
Storage Temperature	T <sub>S</sub>	-40		85	°C	
Case Operating Temperature	T <sub>OP</sub>	-5		85	°C	
Relative Humidity	RH	0		85	%	1

**III. Electrical Characteristics (T<sub>OP</sub> = -5 to 85 °C, V<sub>CC</sub> = 3.00 to 3.60 Volts)**

Parameter	Symbol	Min	Typ	Max	Unit	Ref.
Supply Voltage	V <sub>CC</sub>	3.15		3.60	V	
Supply Current	I <sub>CC</sub>		200	300	mA	
<b>Transmitter</b>						
Input differential impedance	R <sub>in</sub>		100		Ω	2
Single ended data input swing	V <sub>in,pp</sub>	250		1200	mV	
Transmit Disable Voltage	V <sub>D</sub>	V <sub>CC</sub> – 1.3		V <sub>CC</sub>	V	
Transmit Enable Voltage	V <sub>EN</sub>	V <sub>EE</sub>		V <sub>EE</sub> + 0.8	V	3
Transmit Disable Assert Time				10	us	
<b>Receiver</b>						
Single ended data output swing	V <sub>out,pp</sub>	300	400	800	mV	4
Data output rise time	t <sub>r</sub>		100	175	ps	5
Data output fall time	t <sub>f</sub>		100	175	ps	5
LOS Fault	V <sub>LOS fault</sub>	V <sub>CC</sub> – 0.5		V <sub>CC</sub> <sub>HOST</sub>	V	6
LOS Normal	V <sub>LOS norm</sub>	V <sub>EE</sub>		V <sub>EE</sub> +0.5	V	6
Power Supply Rejection	PSR	100			mVpp	7
Deterministic Jitter Contribution	RX Δ DJ			51.7	ps	8
Total Jitter Contribution	RX Δ TJ			122.4	ps	

Notes:

1. Non condensing.
2. Connected directly to TX data input pins. AC coupled thereafter.
3. Or open circuit.
4. Into 100 ohms differential termination.
5. 20 – 80 %
6. Loss Of Signal is LVTTTL. Logic 0 indicates normal operation; logic 1 indicates no signal detected.
7. Receiver sensitivity is compliant with power supply sinusoidal modulation of 20 Hz to 1.5 MHz up to specified value applied through the recommended power supply filtering network. Valid on receive side for input powers within receive sensitivity.
8. Measured with DJ-free data input signal. In actual application, output DJ will be the sum of input DJ and Δ DJ.

**IV. Optical Characteristics (T<sub>OP</sub> = -5 to 85°C, V<sub>CC</sub> = 3.00 to 3.60 Volts)**

Parameter	Symbol	Min	Typ	Max	Unit	Ref.
<b>Transmitter</b>						
Output Opt. Pwr: 9/125 SMF	P <sub>OUT</sub>	0		5	dBm	1
Optical Wavelength	$\lambda$	1540		1570	nm	2
Spectral Width (-20dB)	$\sigma$			1	nm	2
Optical Extinction Ratio	ER	9			dB	
Optical Modulation Amplitude	OMA	174			$\mu$ W	2,3
Sidemode Supression ratio	SSR <sub>min</sub>	30			dB	
Optical Rise/Fall Time	t <sub>r</sub> /t <sub>f</sub>			180	ps	4
Relative Intensity Noise	RIN			-120	dB/Hz	
Deterministic Jitter Contribution	RX $\Delta$ DJ			51.7	ps	5
Total Jitter Contribution	RX $\Delta$ TJ			122.4	ps	
<b>Receiver</b>						
Average Rx Sensitivity @ 2.125 Gb/s (2X Fibre Channel)	R <sub>SENS1</sub>			-21	dBm	6, 7
Average Rx Sensitivity @ 1.25 Gb/s (Gigabit Ethernet)	R <sub>SENS2</sub>			-22	dBm	6, 7
Average Rx Sensitivity @ 1.06 Gb/s (1X Fibre Channel)	R <sub>SENS1</sub>			-22	dBm	6, 7
Stressed RX sens. =1.25 Gb/s			-18	-14.5	dBm	
Average Received Power	R <sub>XMAX</sub>			0	dBm	
Receiver Elec. 3 dB cutoff freq.				1500	MHz	
Optical Center Wavelength	$\lambda_C$	1270		1600	nm	
Return Loss		12			dB	
LOS De-Assert	LOS <sub>D</sub>			-23	dBm	
LOS Assert	LOS <sub>A</sub>	-32			dBm	
LOS Hysteresis		0.5			dB	

**Notes:**

- Class 1 Laser Safety per FDA/CDRH and EN (IEC) 60825 regulations.
- Meets curves in FC-PI 13.0 Figures 18 and 19, which allow trade-off between wavelength, spectral width and OMA.
- Equivalent extinction ratio specification for Fibre Channel. Allows smaller ER at higher average power.
- Unfiltered, 20-80%. Complies with IEEE 802.3 (Gig. E), FC 1x and 2x eye masks when filtered.
- Measured with DJ-free data input signal. In actual application, output DJ will be the sum of input DJ and  $\Delta$  DJ.
- Measured with conformance signals defined in FC-PI 13.0 specifications.
- Measured with PRBS 2<sup>7</sup>-1 at 10<sup>-12</sup> BER

**V. General Specifications**

Parameter	Symbol	Min	Typ	Max	Units	Ref.
Data Rate	BR	1062		2125	Mb/sec	1
Bit Error Rate	BER			$10^{-12}$		2
Max. Supported Link Length on 9/125 $\mu$ m SMF @ 2X Fibre Channel	L <sub>MAX1</sub>		76		km	3, 4
Max. Supported Link Length on 9/125 $\mu$ m SMF @ Gigabit Ethernet	L <sub>MAX2</sub>		88		km	3, 4

**Notes:**

1. Gigabit Ethernet and 1x/2x Fibre Channel compliant.
2. Tested with a PRBS 2<sup>7</sup>-1 test pattern.
3. Dispersion limited per FC-PI Rev. 13
4. Attenuation of 0.25 dB/km is used for the link length calculations. Distances are indicative only and are calculated solely on link budget. A 2dB penalty is included for dispersion on >2Gb/s data rates. Please refer to the Optical Specifications in Table IV to calculate a more accurate link budget based on specific conditions in your application.

**VI. Environmental Specifications**

Finisar 1550nm SFP transceivers have an extended operating temperature range from -5°C to +85°C case temperature.

Parameter	Symbol	Min	Typ	Max	Units	Ref.
Case Operating Temperature	T <sub>op</sub>	-5		85	°C	
Storage Temperature	T <sub>sto</sub>	-40		85	°C	

**VII. Regulatory Compliance**

Finisar transceivers are Class 1 Laser Products and comply with US FDA regulations. These products are certified by TÜV and CSA to meet the Class 1 eye safety requirements of EN (IEC) 60825 and the electrical safety requirements of EN (IEC) 60950. Copies of certificates are available at Finisar Corporation upon request. Copies of the referenced certificates are available at Finisar Corporation upon request.

## VIII. Digital Diagnostic Functions

Finisar FTLF1519P1xNL SFP transceivers support the 2-wire serial communication protocol as defined in the SFP MSA<sup>1</sup>. It is very closely related to the E<sup>2</sup>PROM defined in the GBIC standard, with the same electrical specifications.

The standard SFP serial ID provides access to identification information that describes the transceiver's capabilities, standard interfaces, manufacturer, and other information.

Additionally, Finisar SFP transceivers provide a unique enhanced digital diagnostic monitoring interface, which allows real-time access to device operating parameters such as transceiver temperature, laser bias current, transmitted optical power, received optical power and transceiver supply voltage. It also defines a sophisticated system of alarm and warning flags, which alerts end-users when particular operating parameters are outside of a factory set normal range.

The SFP MSA defines a 256-byte memory map in E<sup>2</sup>PROM that is accessible over a 2-wire serial interface at the 8 bit address 1010000X (A0h). The digital diagnostic monitoring interface makes use of the 8 bit address 1010001X (A2h), so the originally defined serial ID memory map remains unchanged. The interface is identical to, and is thus fully backward compatible with both the GBIC Specification and the SFP Multi Source Agreement. The complete interface is described in Finisar Application Note AN-2030: "Digital Diagnostics Monitoring Interface for SFP Optical Transceivers".

The operating and diagnostics information is monitored and reported by a Digital Diagnostics Transceiver Controller (DDTC) inside the transceiver, which is accessed through a 2-wire serial interface. When the serial protocol is activated, the serial clock signal (SCL, Mod Def 1) is generated by the host. The positive edge clocks data into the SFP transceiver into those segments of the E<sup>2</sup>PROM that are not write-protected. The negative edge clocks data from the SFP transceiver. The serial data signal (SDA, Mod Def 2) is bi-directional for serial data transfer. The host uses SDA in conjunction with SCL to mark the start and end of serial protocol activation. The memories are organized as a series of 8-bit data words that can be addressed individually or sequentially.

For more information, please see the SFP MSA documentation<sup>1</sup> or Finisar Application Note AN-2030.

Digital diagnostics for the FTLF1519P1xNL are externally calibrated by default.

Please note that evaluation board FDB-1018 is available with Finisar ModDEMO software that allows simple to use communication over the 2-wire serial interface.

**IX. Mechanical Specifications**

Finisar’s FTLF1519P1xNL Small Form Factor Pluggable (SFP) transceivers are compatible with the dimensions defined by the SFP Multi-Sourcing Agreement (MSA).

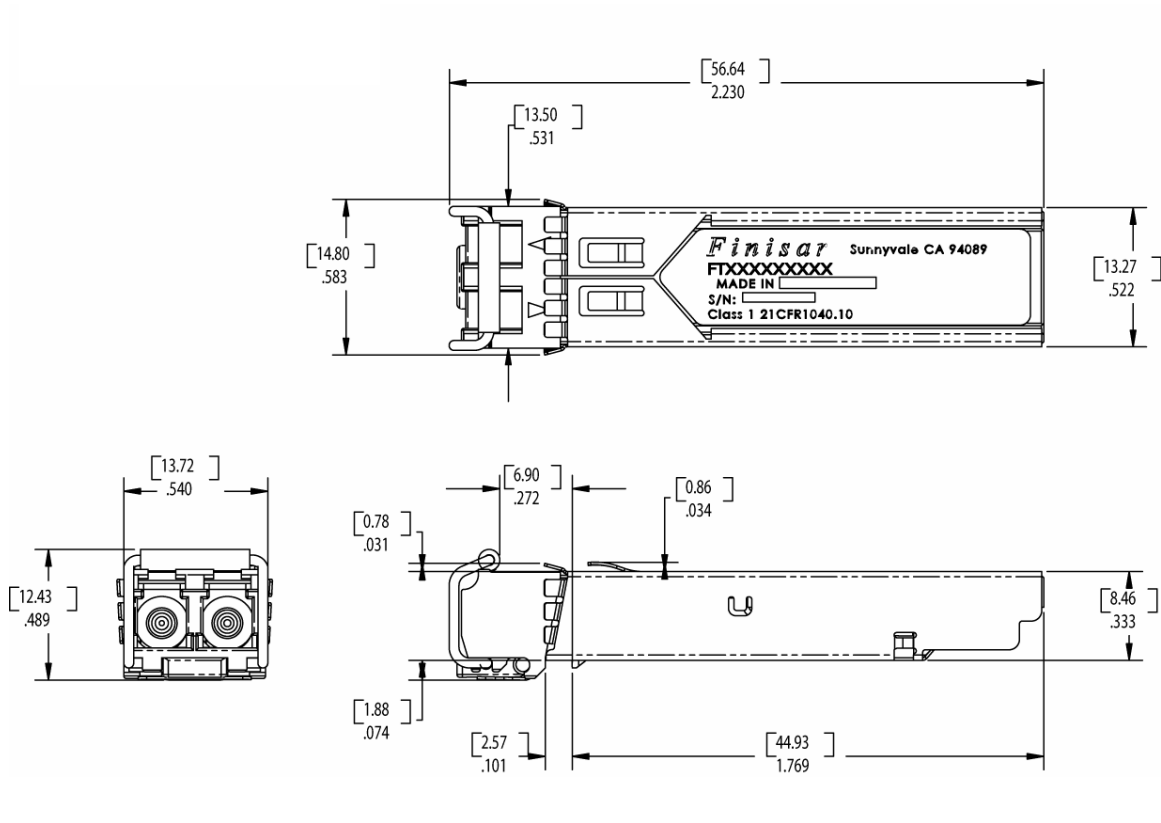

**FTLF1519P1BNL**

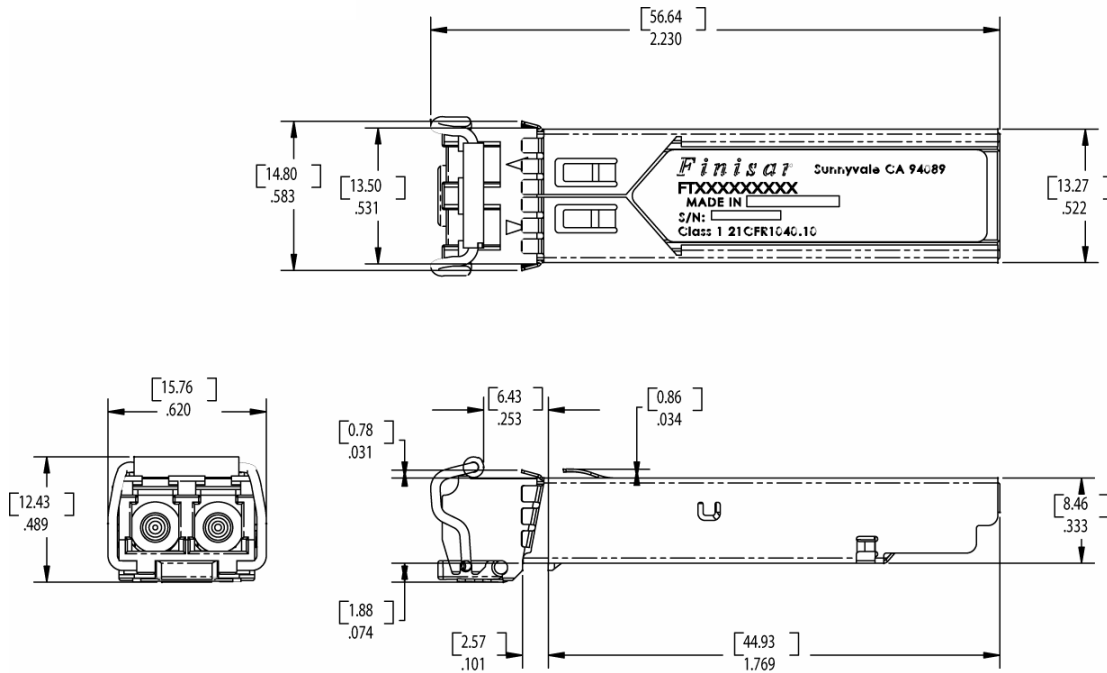

**FTLF1519P1WNL**



**X. PCB Layout and Bezel Recommendations**

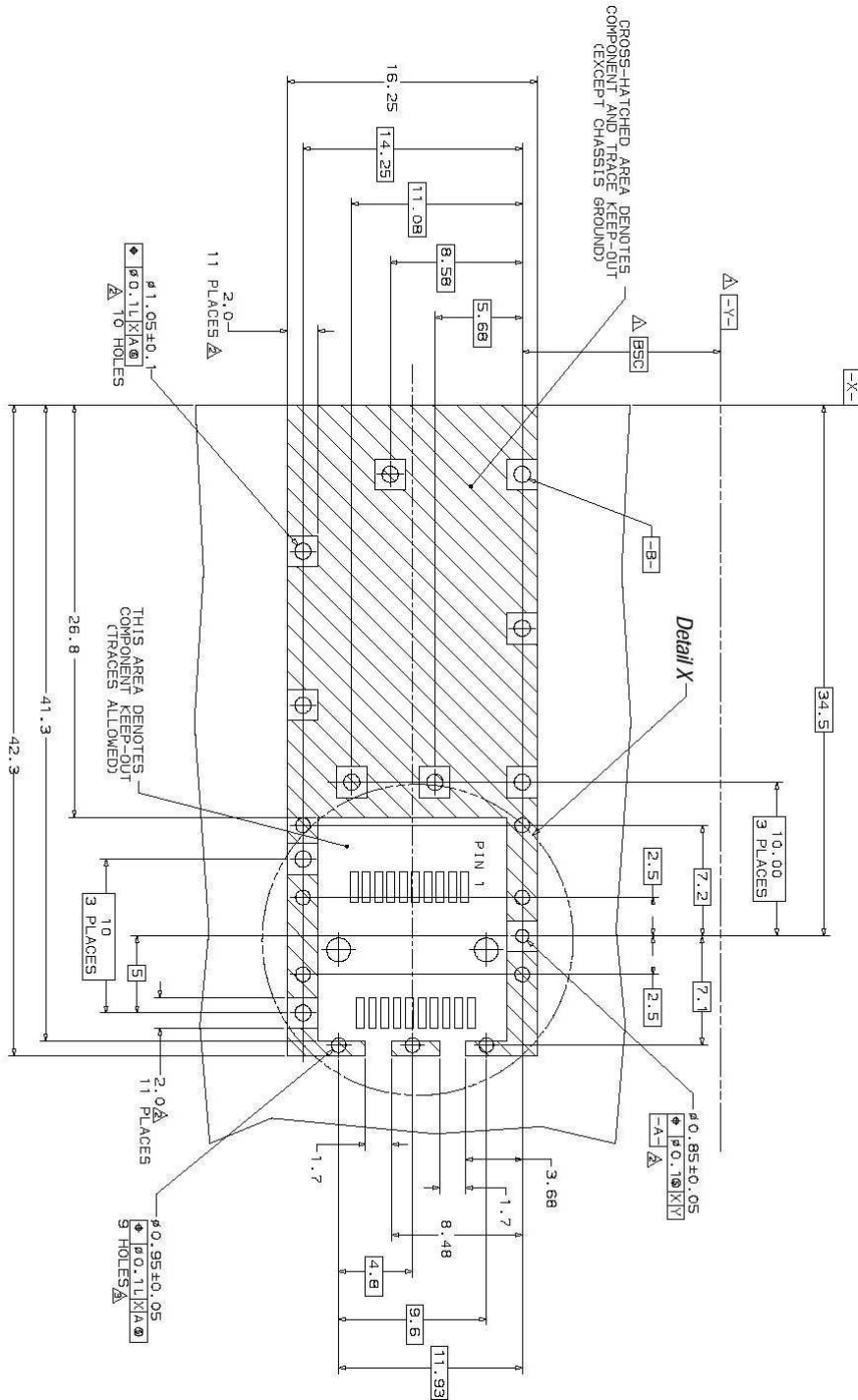

- △ Datum and Basic Dimension Established by Customer
- △ Rads and Vias are Chassis Ground, 11 Places
- △ Through Holes are Unplated

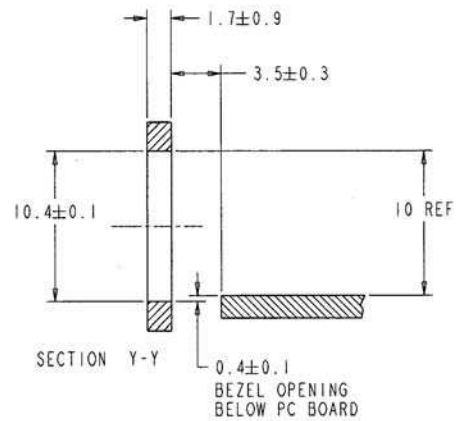
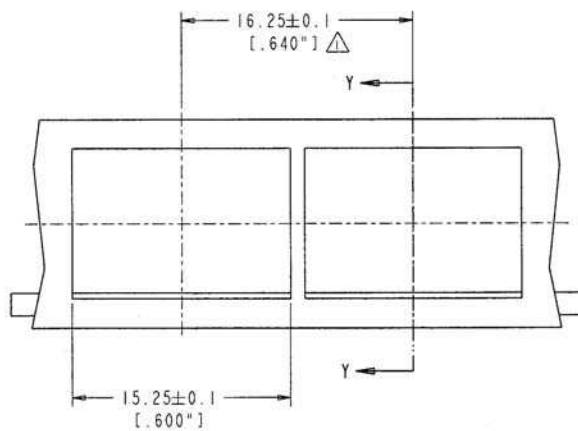
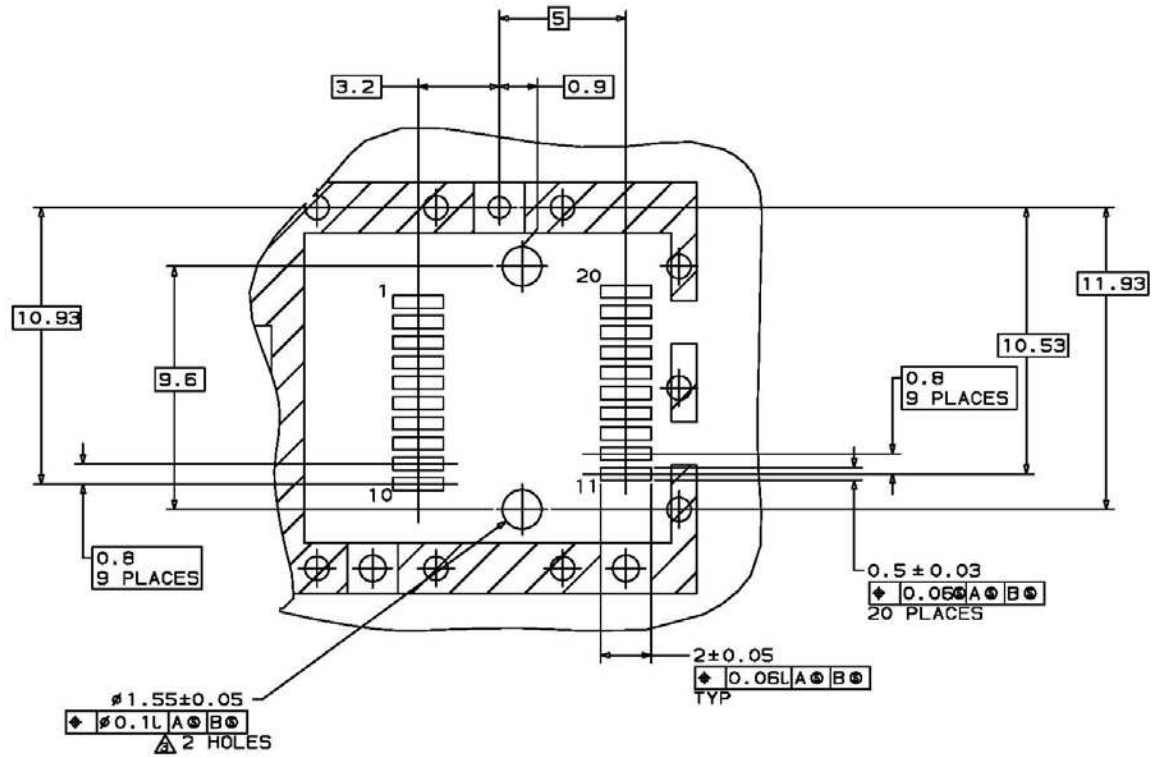

NOTES:

△ MINIMUM PITCH ILLUSTRATED, ENGLISH DIMENSIONS ARE FOR REFERENCE ONLY

2. NOT RECOMMENDED FOR PCI EXPANSION CARD APPLICATIONS

## **XI. References**

1. Small Form Factor Pluggable (SFP) Transceiver Multi-Source Agreement (MSA), September 2000. Documentation is currently available at Finisar upon request.
2. IEEE Std 802.3. IEEE Standards Department, 2002.
3. “Fibre Channel Draft Physical Interface Specification (FC-PI 13.0)”. American National Standard for Information Systems.(\*)
4. “Fibre Channel Physical and Signaling Interface (FC-PH, FC-PH2, FC-PH3)”. American National Standard for Information Systems.
5. Directive 2002/95/EC of the European Council Parliament and of the Council, “on the restriction of the use of certain hazardous substances in electrical and electronic equipment.” January 27, 2003.

(\*) FC-PI 13.0 does not specify a 1550nm DFB interface for extended reach applications. The FTLF1519P1xCL complies with this standard, except for the optical output power. See section IV for details.

## **XII. For More Information**

Finisar Corporation  
1389 Moffett Park Drive  
Sunnyvale, CA 94089-1133  
Tel. 1-408-548-1000  
Fax 1-408-541-6138  
[sales@finisar.com](mailto:sales@finisar.com)  
[www.finisar.com](http://www.finisar.com)