

IRFH7934PbF

HEXFET® Power MOSFET

Applications

- Control MOSFET of Sync-Buck Converters used for Notebook Processor Power
- Control MOSFET for Isolated DC-DC Converters in Networking Systems

| V_{DSS} | $R_{DS(on)}$ max | Qg |
|------------|---|-------------|
| 30V | $3.5m\Omega @ V_{GS} = 10V$ | 20nC |

Benefits

- Very low $R_{DS(ON)}$ at 4.5V V_{GS}
- Low Gate Charge
- Fully Characterized Avalanche Voltage and Current
- 100% Tested for R_G
- Lead-Free (Qualified up to 260°C Reflow)
- RoHS compliant (Halogen Free)
- Low Thermal Resistance
- Large Source Lead for more reliable Soldering

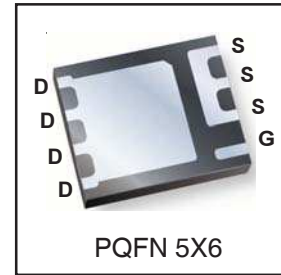
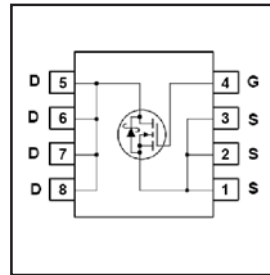

Absolute Maximum Ratings

| | Parameter | Max. | Units |
|--------------------------|--|--------------|-------|
| V_{DS} | Drain-to-Source Voltage | 30 | V |
| V_{GS} | Gate-to-Source Voltage | ± 20 | |
| $I_D @ T_A = 25^\circ C$ | Continuous Drain Current, $V_{GS} @ 10V$ | 24 | A |
| $I_D @ T_A = 70^\circ C$ | Continuous Drain Current, $V_{GS} @ 10V$ | 19 | |
| $I_D @ T_C = 25^\circ C$ | Continuous Drain Current, $V_{GS} @ 10V$ | 76 | |
| I_{DM} | Pulsed Drain Current ① | 190 | |
| $P_D @ T_A = 25^\circ C$ | Power Dissipation ⑤ | 3.1 | W |
| $P_D @ T_A = 70^\circ C$ | Power Dissipation ⑤ | 2.0 | |
| | Linear Derating Factor ⑤ | 0.025 | W/°C |
| T_J | Operating Junction and | -55 to + 150 | °C |
| T_{STG} | Storage Temperature Range | | |

Thermal Resistance

| | Parameter | Typ. | Max. | Units |
|-----------------|-----------------------|------|------|-------|
| $R_{\theta JC}$ | Junction-to-Case ④ | — | 2.9 | °C/W |
| $R_{\theta JA}$ | Junction-to-Ambient ⑤ | — | 40 | |

ORDERING INFORMATION:

See detailed ordering and shipping information on the last page of this data sheet.

Notes ① through ⑤ are on page 10

www.irf.com

Static @ $T_J = 25^\circ\text{C}$ (unless otherwise specified)

| | Parameter | Min. | Typ. | Max. | Units | Conditions |
|------------------------------|--------------------------------------|------|-------|------|----------------------|---|
| BV_{DSS} | Drain-to-Source Breakdown Voltage | 30 | — | — | V | $V_{GS} = 0V, I_D = 250\mu A$ |
| $\Delta BV_{DSS}/\Delta T_J$ | Breakdown Voltage Temp. Coefficient | — | 0.021 | — | $V/^\circ\text{C}$ | Reference to $25^\circ\text{C}, I_D = 1\text{mA}$ |
| $R_{DS(on)}$ | Static Drain-to-Source On-Resistance | — | 2.9 | 3.5 | m Ω | $V_{GS} = 10V, I_D = 24A$ ③ |
| | | — | 4.2 | 5.1 | | $V_{GS} = 4.5V, I_D = 19A$ ③ |
| $V_{GS(th)}$ | Gate Threshold Voltage | 1.35 | 1.8 | 2.35 | V | $V_{DS} = V_{GS}, I_D = 50\mu A$ |
| $\Delta V_{GS(th)}$ | Gate Threshold Voltage Coefficient | — | -6.5 | — | mV/ $^\circ\text{C}$ | |
| I_{DSS} | Drain-to-Source Leakage Current | — | — | 1.0 | μA | $V_{DS} = 24V, V_{GS} = 0V$ |
| | | — | — | 150 | | $V_{DS} = 24V, V_{GS} = 0V, T_J = 125^\circ\text{C}$ |
| I_{GSS} | Gate-to-Source Forward Leakage | — | — | 100 | nA | $V_{GS} = 20V$ |
| | Gate-to-Source Reverse Leakage | — | — | -100 | | $V_{GS} = -20V$ |
| gfs | Forward Transconductance | 110 | — | — | S | $V_{DS} = 15V, I_D = 19A$ |
| Q_g | Total Gate Charge | — | 20 | 30 | nC | $V_{DS} = 15V$ $V_{GS} = 4.5V$ $I_D = 19A$ See Fig.17 & 18 |
| Q_{gs1} | Pre-Vth Gate-to-Source Charge | — | 4.8 | — | | |
| Q_{gs2} | Post-Vth Gate-to-Source Charge | — | 2.5 | — | | |
| Q_{gd} | Gate-to-Drain Charge | — | 6.3 | — | | |
| Q_{godr} | Gate Charge Overdrive | — | 6.4 | — | | |
| Q_{sw} | Switch Charge ($Q_{gs2} + Q_{gd}$) | — | 8.8 | — | | |
| Q_{oss} | Output Charge | — | 15 | — | nC | $V_{DS} = 16V, V_{GS} = 0V$ |
| R_G | Gate Resistance | — | 1.7 | 3.1 | Ω | |
| $t_{d(on)}$ | Turn-On Delay Time | — | 12 | — | ns | $V_{DD} = 15V, V_{GS} = 4.5V$ $I_D = 19A$ $R_G = 1.8\Omega$ See Fig.15 |
| t_r | Rise Time | — | 16 | — | | |
| $t_{d(off)}$ | Turn-Off Delay Time | — | 14 | — | | |
| t_f | Fall Time | — | 7.5 | — | | |
| C_{iss} | Input Capacitance | — | 3100 | — | pF | $V_{GS} = 0V$ $V_{DS} = 15V$ $f = 1.0\text{MHz}$ |
| C_{oss} | Output Capacitance | — | 623 | — | | |
| C_{riss} | Reverse Transfer Capacitance | — | 241 | — | | |

Avalanche Characteristics

| | Parameter | Typ. | Max. | Units |
|----------|---------------------------------|------|------|-------|
| E_{AS} | Single Pulse Avalanche Energy ② | — | 97 | mJ |
| I_{AR} | Avalanche Current ① | — | 19 | A |

Diode Characteristics

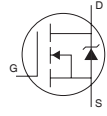
| | Parameter | Min. | Typ. | Max. | Units | Conditions |
|----------|---|--|------|------|-------|--|
| I_S | Continuous Source Current (Body Diode) | — | — | 3.9 | A | MOSFET symbol showing the integral reverse p-n junction diode.  |
| I_{SM} | Pulsed Source Current (Body Diode) ① | — | — | 190 | | |
| V_{SD} | Diode Forward Voltage | — | — | 1.0 | V | $T_J = 25^\circ\text{C}, I_S = 19A, V_{GS} = 0V$ ③ |
| t_{rr} | Reverse Recovery Time | — | 20 | 30 | ns | $T_J = 25^\circ\text{C}, I_F = 19A, V_{DD} = 15V$ |
| Q_{rr} | Reverse Recovery Charge | — | 28 | 42 | nC | $di/dt = 325A/\mu s$ ③ See Fig.16 |
| t_{on} | Forward Turn-On Time | Intrinsic turn-on time is negligible (turn-on is dominated by LS+LD) | | | | |

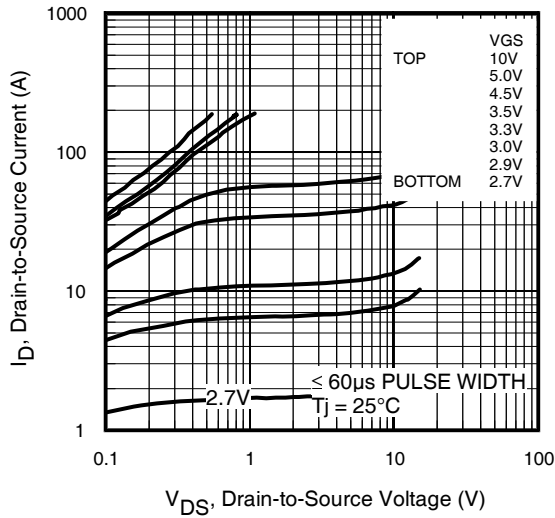

Fig 1. Typical Output Characteristics

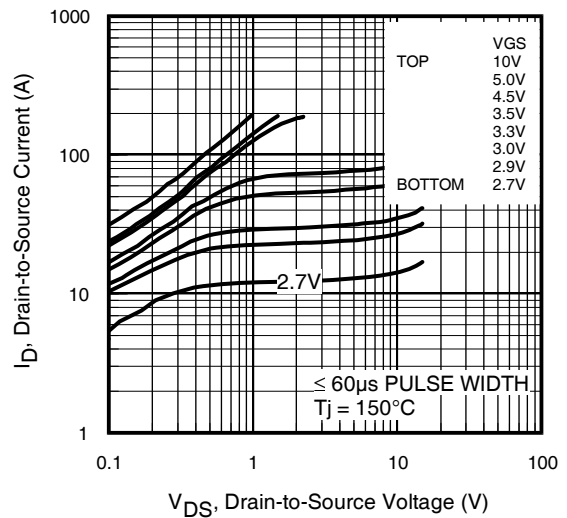

Fig 2. Typical Output Characteristics

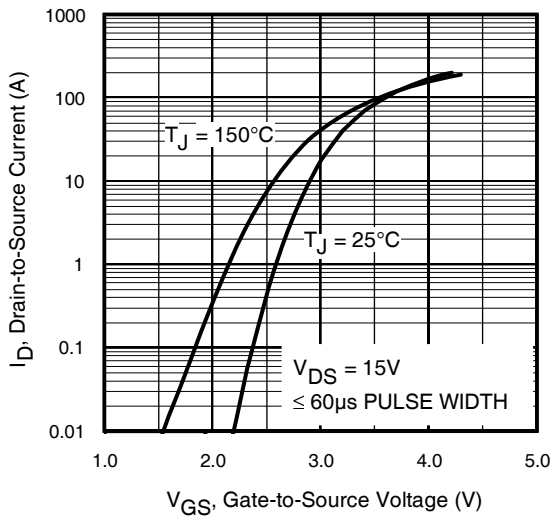

Fig 3. Typical Transfer Characteristics

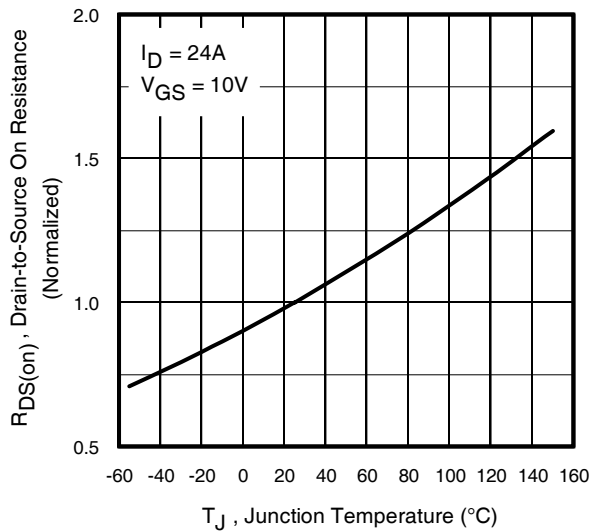

Fig 4. Normalized On-Resistance vs. Temperature

IRFH7934PbF

International
IR Rectifier

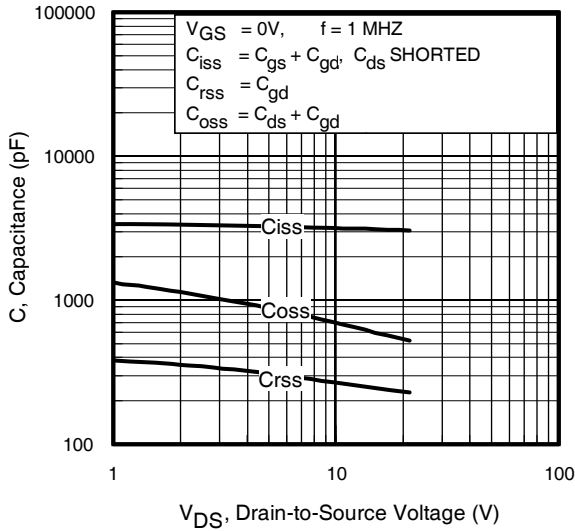

Fig 5. Typical Capacitance Vs. Drain-to-Source Voltage

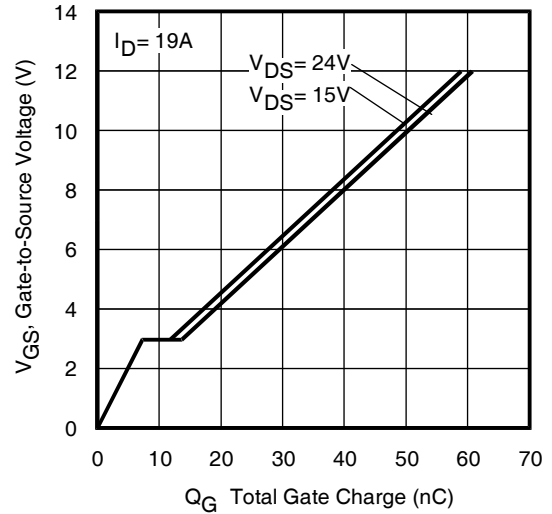

Fig 6. Typical Gate Charge vs. Gate-to-Source Voltage

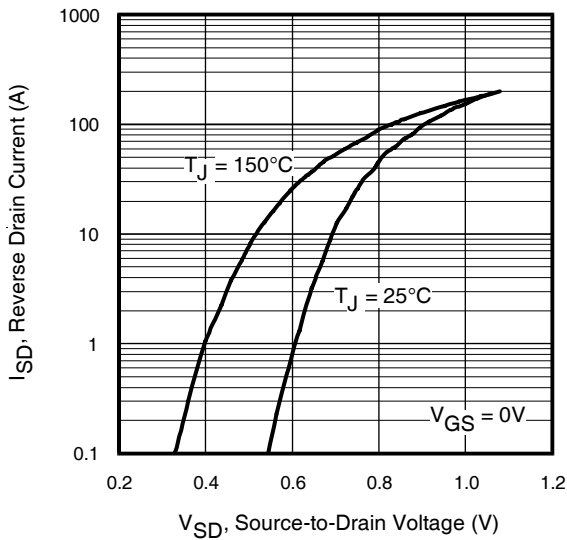

Fig 7. Typical Source-Drain Diode Forward Voltage

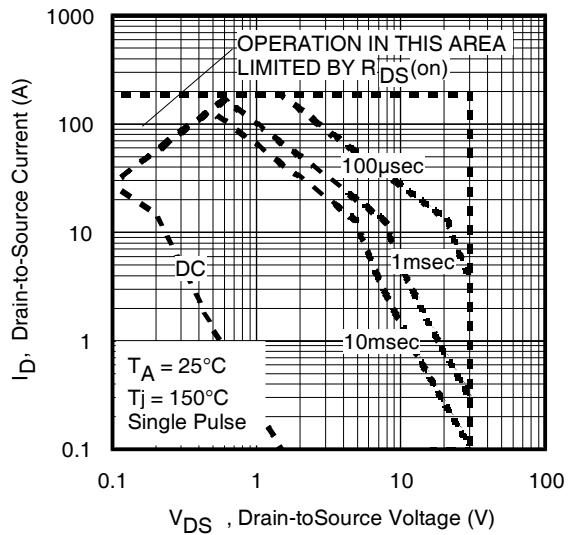

Fig 8. Maximum Safe Operating Area

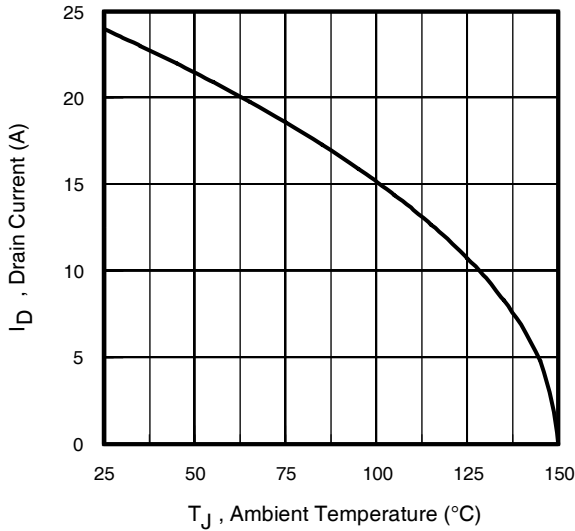

Fig 9. Maximum Drain Current vs. Ambient Temperature

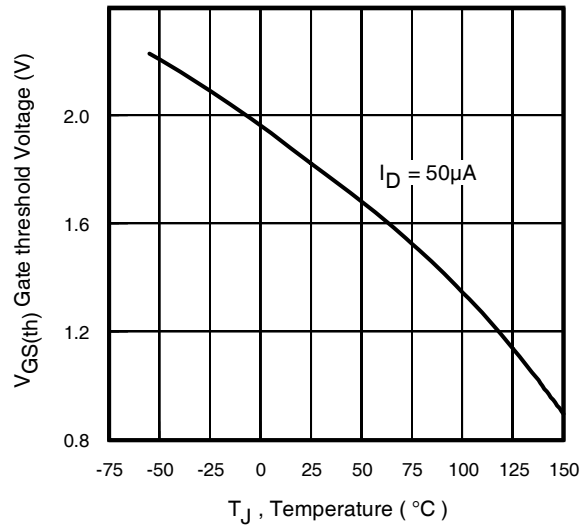

Fig 10. Threshold Voltage vs. Temperature

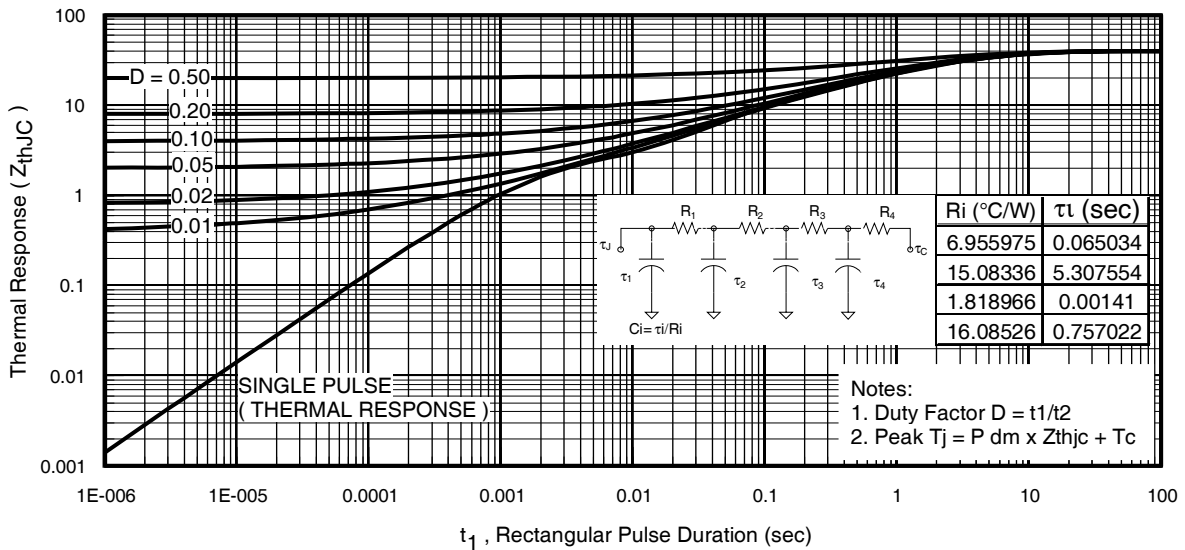

Fig 11. Maximum Effective Transient Thermal Impedance, Junction-to-Ambient

IRFH7934PbF

International
IR Rectifier

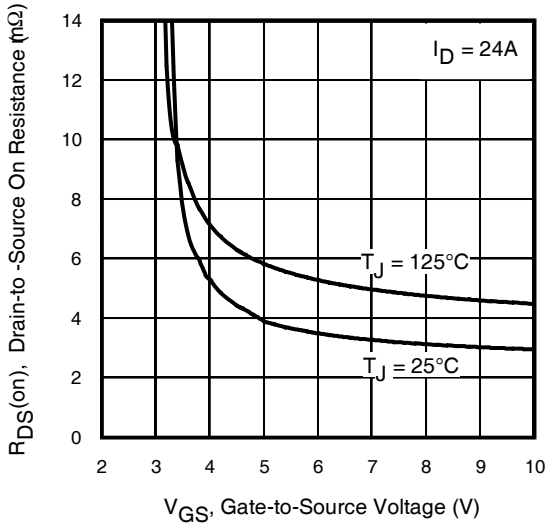

Fig 12. On-Resistance vs. Gate Voltage

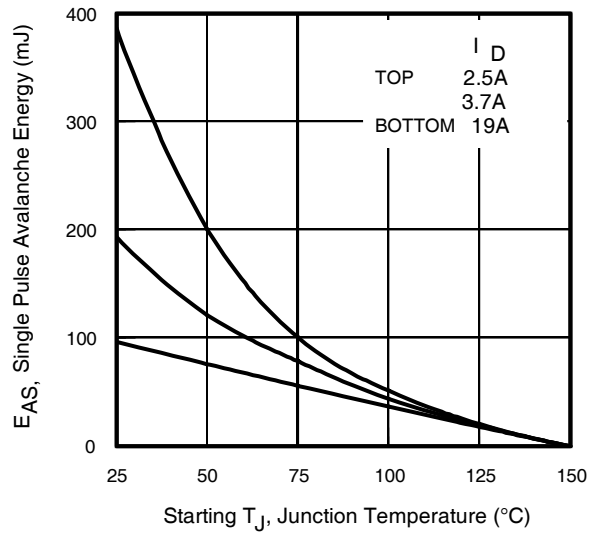

Fig 13. Maximum Avalanche Energy vs. Drain Current

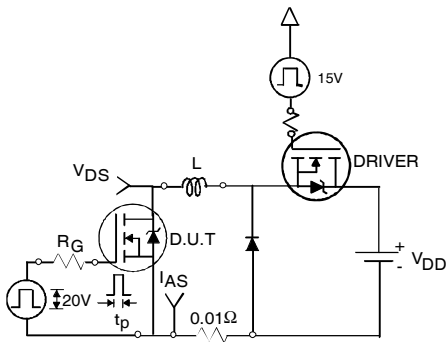

Fig 14a. Unclamped Inductive Test Circuit

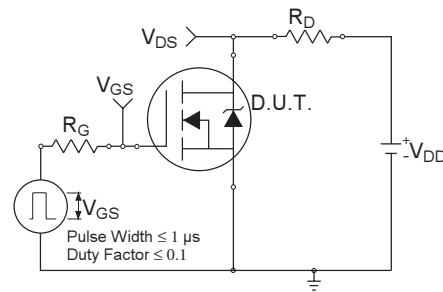

Fig 15a. Switching Time Test Circuit

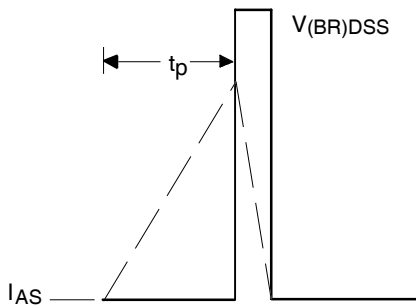

Fig 14b. Unclamped Inductive Waveforms

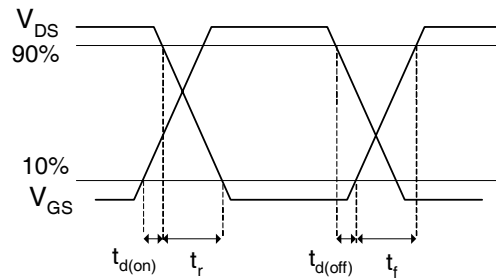

Fig 15b. Switching Time Waveforms

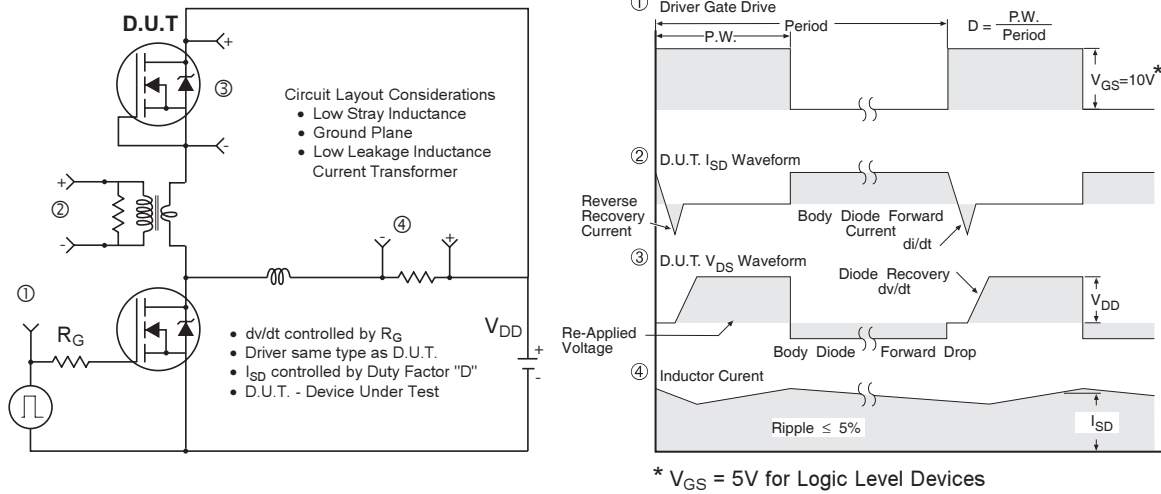

Fig 16. Peak Diode Recovery dv/dt Test Circuit for N-Channel HEXFET® Power MOSFETS

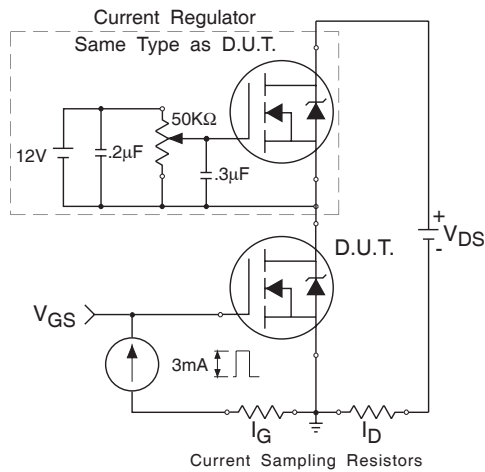

Fig 17. Gate Charge Test Circuit

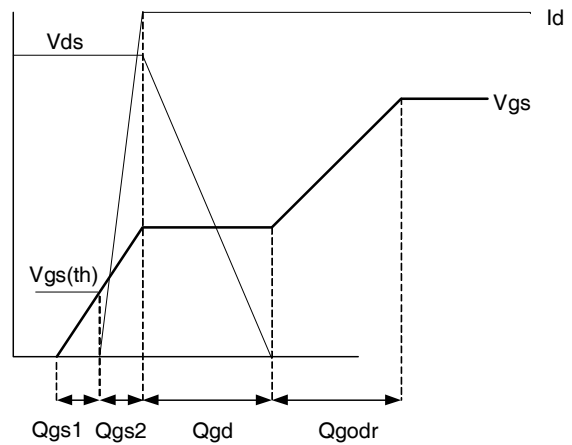
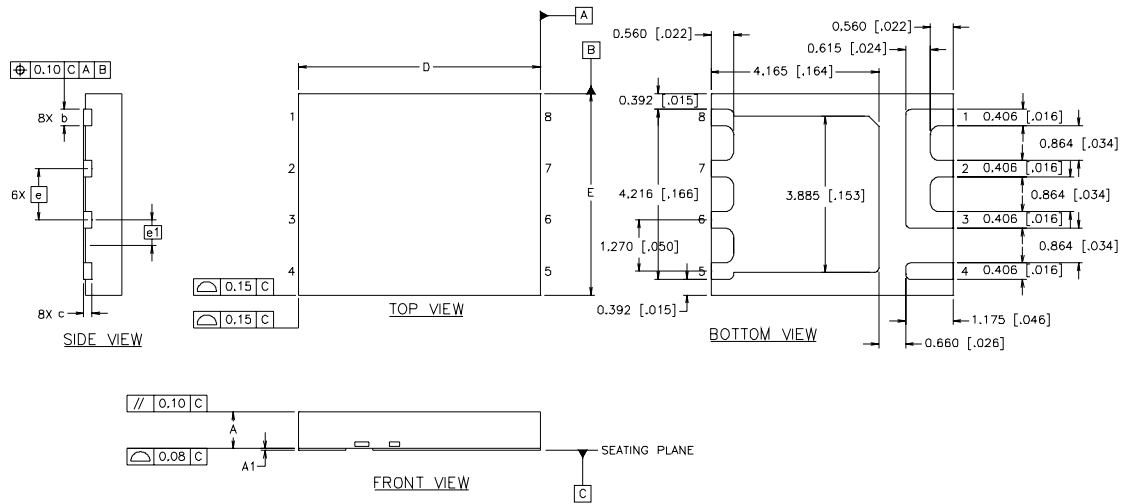

Fig 18. Gate Charge Waveform

PQFN Package Details



| DIM | INCHES | | MILLIMETERS | |
|-----|-------------|-------|-------------|-------|
| | MIN | MAX | MIN | MAX |
| A | .0315 | .0394 | 0.800 | 1.000 |
| A1 | .0000 | .0020 | 0.000 | 0.050 |
| b | .0140 | .0180 | 0.356 | 0.456 |
| c | .0080 REF. | | 0.203 REF. | |
| D | .2362 BASIC | | 6.0 BASIC | |
| E | .1969 BASIC | | 5.0 BASIC | |
| e | .0500 BASIC | | 1.270 BASIC | |
| e1 | .0250 BASIC | | 0.635 BASIC | |

Note: For the most current drawing please refer to IR website at <http://www.irf.com/package/>

PQFN Part Marking

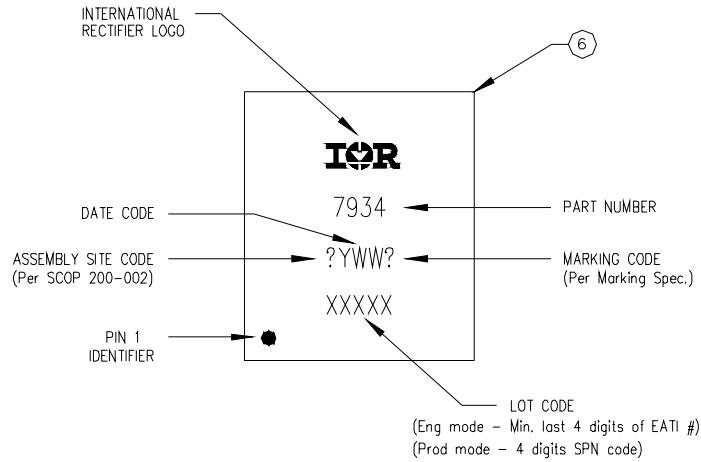

PQFN Tape and Reel

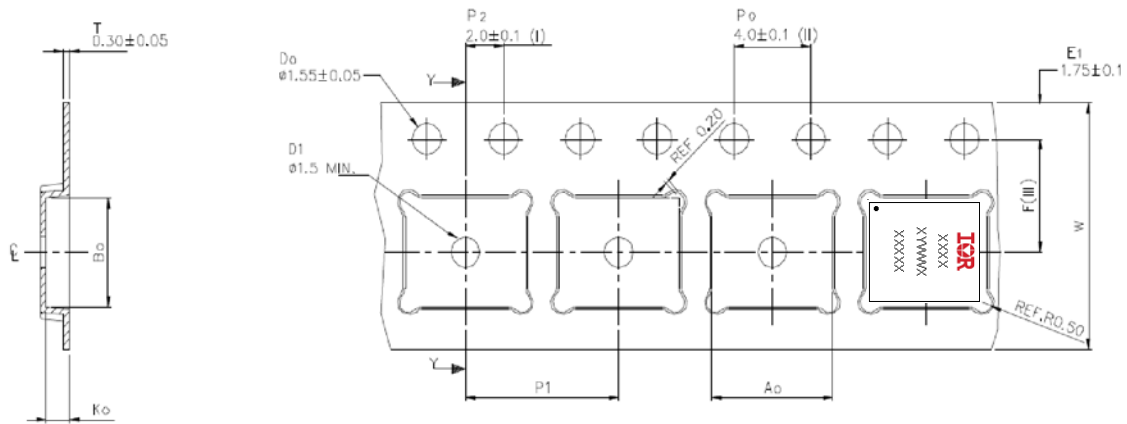

| | |
|----|---------------|
| A0 | 6.30 +/- 0.1 |
| B0 | 5.30 +/- 0.1 |
| K0 | 1.20 +/- 0.1 |
| F | 5.50 +/- 0.1 |
| P1 | 8.00 +/- 0.1 |
| W | 12.00 +/- 0.3 |

- (I) Measured from centreline of sprocket hole to centreline of pocket.
- (II) Cumulative tolerance of 10 sprocket holes is ± 0.20 .
- (III) Measured from centreline of sprocket hole to centreline of pocket.
- (IV) Other material available.
- (V) Typical SR of form tape Max 10^9 OHM/SQ

ALL DIMENSIONS IN MILLIMETRES UNLESS OTHERWISE STATED

Note: For the most current drawing please refer to IR website at: <http://www.irf.com/package/>
www.irf.com

IRFH7934PbF

International
IR Rectifier

| Orderable part number | Package Type | Standard Pack | | Note |
|-----------------------|----------------|---------------|----------|------|
| | | Form | Quantity | |
| IRFH7934TRPBF | PQFN 5mm x 6mm | Tape and Reel | 4000 | |

Qualification information[†]

| | | | |
|----------------------------|--|---|--|
| Qualification level | Consumer ^{††} (per JEDEC JES D47F ^{†††} guidelines) | | |
| Moisture Sensitivity Level | PQFN 5mm x 6mm | MSL2 ^{††††} (per JEDEC J-ST D-020D ^{†††}) | |
| RoHS compliant | Yes | | |

† Qualification standards can be found at International Rectifier's web site

<http://www.irf.com/product-info/reliability>

†† Higher qualification ratings may be available should the user have such requirements.

Please contact your International Rectifier sales representative for further information:

<http://www.irf.com/whoto-call/salesrep/>

††† Applicable version of JEDEC standard at the time of product release.

†††† Higher MSL ratings may be available for the specific package types listed here.

Please contact your International Rectifier sales representative for further information:

<http://www.irf.com/whoto-call/salesrep/>

Notes:

- ① Repetitive rating; pulse width limited by max. junction temperature.
- ② Starting $T_J = 25^\circ\text{C}$, $L = 0.535\text{mH}$, $R_G = 25\Omega$, $I_{AS} = 19\text{A}$.
- ③ Pulse width $\leq 400\mu\text{s}$; duty cycle $\leq 2\%$.
- ④ R_{thjc} is guaranteed by design
- ⑤ When mounted on 1 inch square 2 oz copper pad on 1.5x1.5 in. board of FR-4 material.

Data and specifications subject to change without notice.

International
IR Rectifier

IR WORLD HEADQUARTERS: 233 Kansas St., El Segundo, California 90245, USA Tel: (310) 252-7105

TAC Fax: (310) 252-7903

Visit us at www.irf.com for sales contact information.2/2009