

# ODB9733 Series

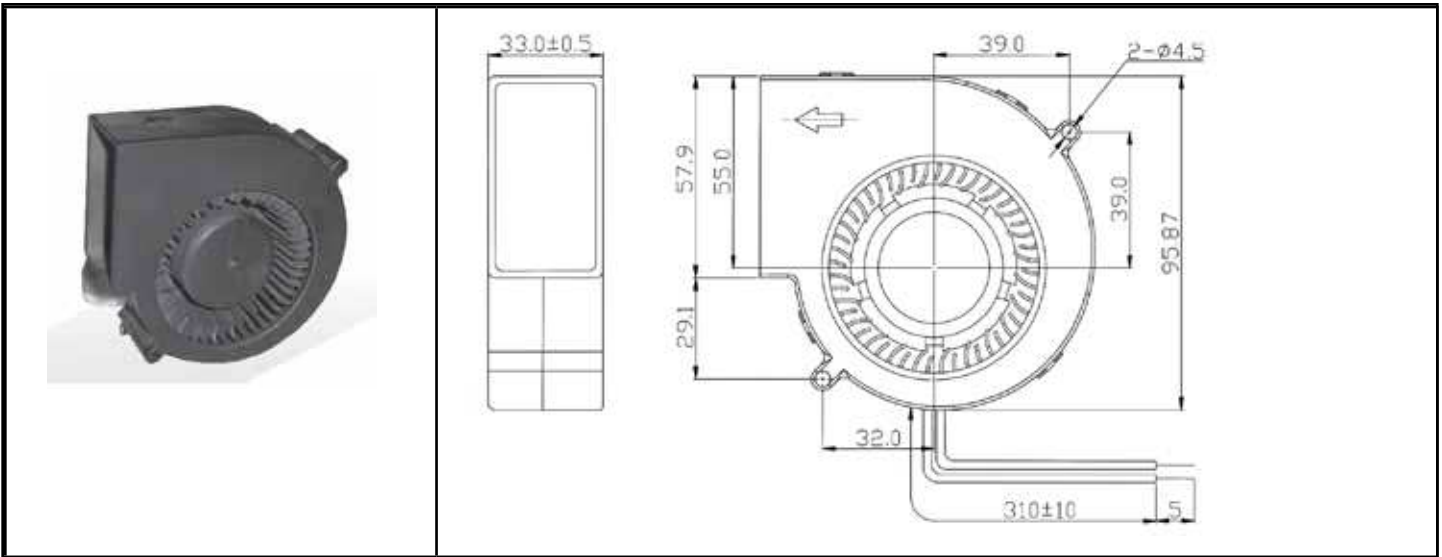

DC side inlet blower  
96x33mm (3.8"x 1.3")



Frame	PBT, UL94V-0	Notes	
Impeller	PBT, UL94V-0	Date: 052012	
Connection	Lead wires*	<u>Available Options</u>	
Motor	Brushless DC, IC protected	Tachometer	
Bearing System	Dual ball bearing	Alarm	
Insulation Resistance	10M ohm between lead wire and frame (500VDC)	Thermal Control	
Dielectric Strength	60 second at 500VAC, max. leakage < 500 MicroAmp	* Connections UL1007, AWG24, ~310mm Red (+) Black (-)	
Temperature Range	-10C ~ +70C		
Life Expectancy	50000 hours (25C L10)		

Model Number	ODB9733-12HB	ODB9733-24HB
Part Number	104141001	104241001
Nominal Voltage	12 VDC	24 VDC
Voltage Range	10.8 ~ 13.2 VDC	21.6 ~ 26.4 VDC
Nominal Current	0.78 A	0.35 A
Input Power	9.36 W	8.40 W
Rated Speed (RPM)	4000	4000
Airflow (CFM)	33	33
Noise Level (dB)	56	56
Max. Static Pressure ( " H <sub>2</sub> O)	1.1	1.1