

VFH240C Series

XO Hi-Rel/COTS

5x7mm SMD, 2.5V, 3.3V LVPECL / LVDS



Features

- 9.5MHz to 640MHz frequency range
- Low <0.5 ps RMS jitter over 12K-20M,
- LVPECL or LVDS output with tristate
- SMD package (5x7 mm)
- Stability options from ± 25 ppm to ± 75 ppm
- Leadless chip carrier package is hermetically sealed for superior aging and field performance
- Crystal angle controlled to ± 0.5 for excellent temperature stability
- 168 hour Class B burn-in and extensive environmental testing for best performance in rugged field environments
- Serialized test data available
- Calculated MTBF is 3.8×10^6 hours at 125°C

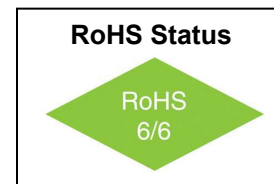

Description:

These high reliability oscillators provide LVPECL/LVDS outputs for applications subjected to the most stringent environmental conditions. They are mechanically robust and weigh less than 0.2 grams. This 5x7 mm SMD package has a hermetic seal, thus ensuring the integrity of each part. Each oscillator is burned-in at 125°C for 168 hours, temperature cycled and centrifuged then fully tested in accordance with Table 1. Reliability tests are performed per Table 2.

Electrical Specifications

Parameter	Symbol	Condition	Min	Typ	Max	Unit	Note
Frequency Range	F		9.5		640	MHz	
Frequency Stability	$\Delta F/F$	Vs. Operating Temperature			± 75 ± 50 ± 25	ppm	Order Code A Order Code B Order Code C
		Vs. Supply Voltage Vs. Aging / Year		± 3 ± 3 ± 1		ppm/V ppm ppm	First Year After first year
Operating Temperature Frequency Range	T		-55° -40° -55		+125° +85° +85	°C	Order Code E Order Code G Order code H
Output	$\Delta F/F$						Order Code L Order Code D
Supply Voltage	V _{CC}		3.15 2.25	3.3 2.5	3.45 2.75	V	Order Code E Order Code G
Period Jitter RMS		77.76MHz		2.5	4	ps	
		155.52MHz		3	4		
		311.08MHz		3	5		
		622.08MHz		6	8		

Electrical Specifications

Parameter	Symbol	Condition	Min	Typ	Max	Unit	Note
Integrated Jitter RMS 12KHz to 20MHz		155.52MHz		0.4	0.5	ps	
		311.04MHz		0.4	0.5		
		622.08MHz		0.4	0.5		
Period Jitter Peak-to-Peak		77.76MHz		18	30	ps	
		155.52MHz		20	30		
		311.08MHz		25	30		
		622.08MHz		42	55		
Symmetry		$(V_{DD}-1.3) V_{DC}$ $1.25V_{DC}$	45 45		55 55	%	PECL LVDS
Phase Noise		10Hz		-66		dBc/Hz	@77.76MHz
		100Hz		-96			
		1kHz		-124			
		10kHz		-136			
		100kHz		-132			
		10Hz		-62		dBc/Hz	@155.52MHz
		100Hz		-92			
		1kHz		-120			
		10kHz		-132			
		100kHz		-128			
		10Hz		-59		dBc/Hz	@311.04MHz
		100Hz		-86			
		1kHz		-116			
		10kHz		-129			
		100kHz		-124			
		10Hz		-48		dBc/Hz	@622.08MHz
		100Hz		-80			
		1kHz		-108			
		10kHz		-118			
		100kHz		-114			
Input Current	I_{CC}	38 – 100MHz			65	mA	PECL
		100 – 300MHz			80		
		300 – 640MHz			90		
		38 – 100MHz			45	mA	LVDS
		100 – 320MHz			60		
		320 – 640MHz			70		

VFH240C Series
XO Hi-Rel/COTS
5x7mm SMD, 2.5V, 3.3V LVPECL / LVDS



Electrical Specifications

Parameter	Symbol	Condition	Min	Typ	Max	Unit	Note	
Load		50 Ohms to $V_{DD}-2V$ (PECL) 100 Ohms (LVDS)						
Output High Voltage	V_{OH}			$V_{DD}-1.025$ 1.4	1.6	V	PECL LVDS	
Output Low Voltage	V_{OL}		0.9	1.1	$V_{DD}-1.620$	V	PECL LVDS	
Output Differential Voltage	V_{OD}		247	355	454	mV	LVDS	
Offset Voltage	V_{OS}		1.125	1.2	1.375	V	LVDS	
Rise / Fall Time	Tr/Tf	20% to 80%		0.6 0.7	1.5 1.0	ns	PECL LVDS	
Tristate		"1": Output Enable – Pin 1 may float or 2.8V min (3.3V V_{DD}) or 2.25V min (2.5V V_{DD}) "0": Tristate – Pin 1 requires 0.4V max (3.3V or 2.5V V_{DD})						

Absolute Maximum Rating

Parameter	Symbol	Condition	Min	Typ	Max	Unit	Note
Lead Temperature		Soldering, 10s max			260	°C	
Storage Temperature	T_s				-55	°C	
Junction Temperature	T_J				+125°	°C	
ESD Protection		Human Body Model			2	KV	
Thermal Resistance	$R\theta_{JC}$	Junction to case		16		°C/Watt	

Environmental and Mechanical Conditions

Parameter	Specification
Shock	MIL-STD 883, Method 2002, Test Condition B (1500 peak g, 0.5 ms duration, ½ sine wave, 5 shocks in 6 planes)
Humidity	Resistant to 85 °R.H. at 85 °C
Vibration	MIL-STD 883, Method 2007, Test Condition A (20-2000Hz of 0.06" d.a. or 20 Gs, whichever is less)
Leak	MIL STD 883, Method 1014, Condition A and Condition C
Case	Ceramic with hermetic resistance-welded metal lid
Pads	Solderable gold over nickel
Marking	Epoxy ink or laser engraved
Resistance to Solvents	MIL STD 202, Method 215

Recommended Reflow Soldering Profile

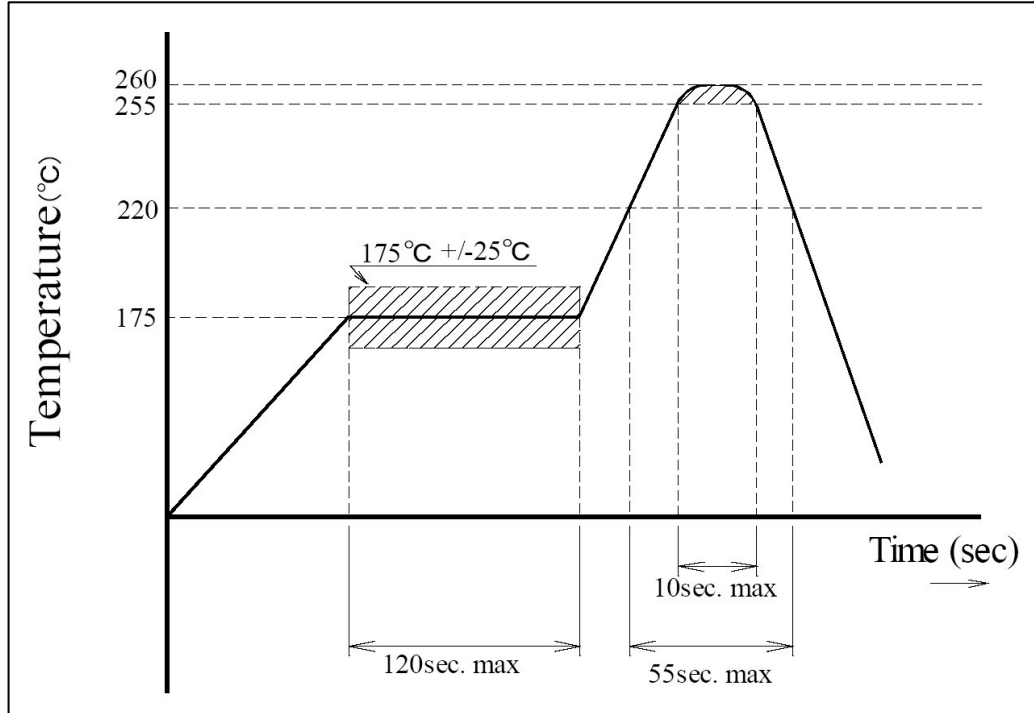

Table 1

Each unit undergoes screening for product level B class 2 oscillators by MIL-PRF-55310

Internal Visual	MIL-STD-883 Method 1008, COND. B
Stabilization Bake	MIL-STD-883 Method 1010, COND. B
Temperature Cycling	MIL-STD-883 Method 2001, COND. A
Constant Acceleration	MIL-STD-883 Method 1014, COND. A
Fine Leak	MIL-STD-883 Method 1014, COND. C
Gross Leak	MIL-STD-883 Method 1015, COND. B
Burn-in	(125°C for 160 hours with bias)

Electrical test at 25°C	
Current	Frequency at max V_{DD}
Rise Time	Frequency at min V_{DD}
Fall Time	"Zero" logic level
Duty Cycle	"One" logic level
Tristate	
Frequency at 25°C and frequency verification at temperature extremes	

Serialized test data on each unit available upon request for additional cost.

Thermal Characteristics

Thermal Resistance

From Junction to Case, $R_{\theta jc}$ 16 °C/Watt

Surface Mount Application

These packages are designed for reflow soldering in accordance with recommended profiles. For hand-soldering, the temperature of the iron should not exceed 400°C for three seconds.

VFH240C Series XO Hi-Rel/COTS 5x7mm SMD, 2.5V, 3.3V LVPECL / LVDS



How to Order:

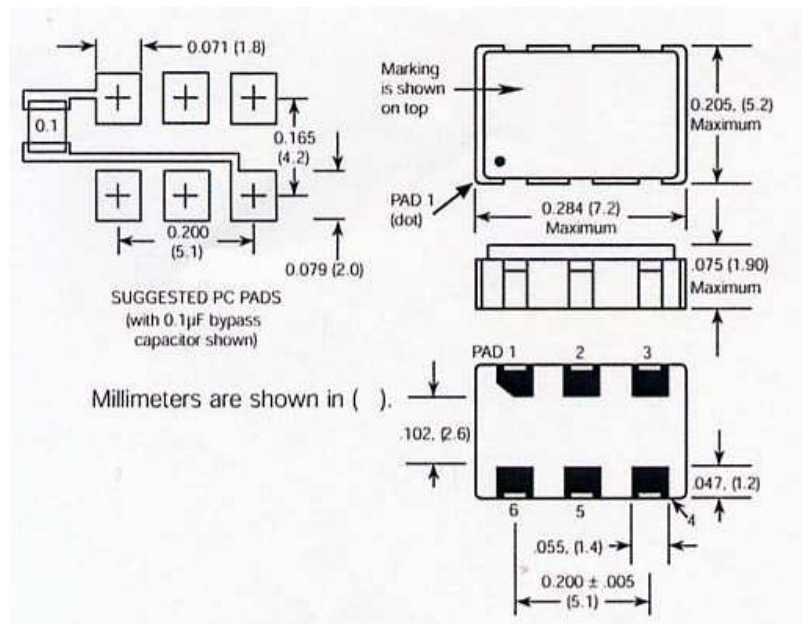
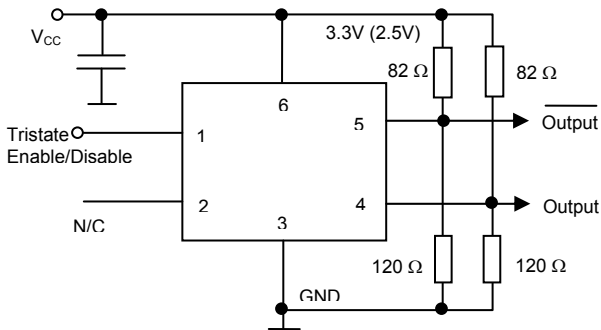
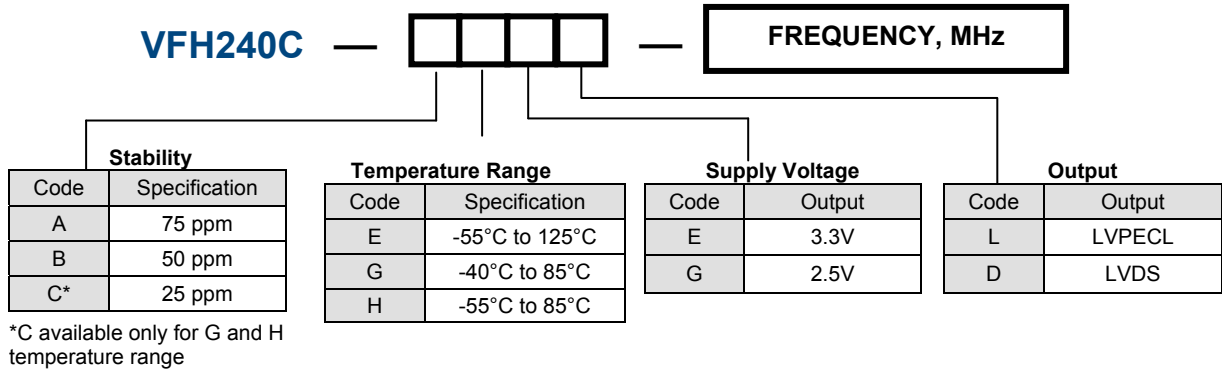

Marking Specification

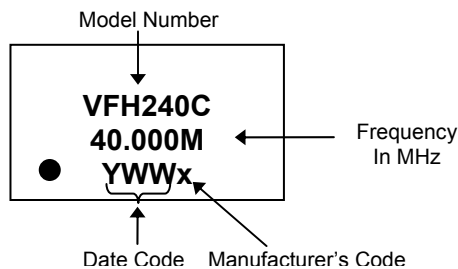

Pin Assignment

Pin #	Connection
1	Tristate
2	N/C
3	Case, GND
4	Output
5	Output
6	Supply Voltage

VFH240C Series

XO Hi-Rel/COTS

5x7mm SMD, 2.5V, 3.3V LVPECL / LVDS



TABLE 2
Reliability Test Procedures and Conditions for Quartz Crystal Oscillators

1. Group A

Electrical Characteristics at 25°C

- Frequency at nominal supply voltage and endpoints
- Input current
- Symmetry (Duty Cycle)
- Zero/One levels
- Rise/Fall times
- Frequency (verify frequency at the temperature extremes)

Physical Dimensions

- Length/width
- Height
- Package finish (Corrosion, discoloration, etc.)
- Marking placement/legibility

2. Group B

1000 hrs at or above 125°C, nominal voltage, proper load (sample size by MIL -PRF-55310 table 6, max. aging within 15 years requirement without catastrophic failures)

3. Group C- All units have passed Group A testing

A. Subgroup 1: 8 pcs.

<u>Standard</u>	<u>Condition</u>	<u>Description</u>	<u>End Point Measurement</u>
MIL-STD-883	Method 2002 COND.B	Mechanical Shock 1500 g's, 0.5ms 5 drops, 6 axis	Frequency Output waveform
MIL-STD-883	Method 2007 COND. A	Vibration, var. freq. 20 g's, 0.06" disp., 20- 20, 000-20 Hz	Frequency Output waveform
MIL-STD-883	Method 2003	Solderability	Visual 95% Coverage

B. Subgroup 2: 4 pcs (One-half of Subgroup 1)

<u>Standard</u>	<u>Condition</u>	<u>Description</u>	<u>End point Measurement</u>
MIL-STD-883	Method 1011 COND. B	Thermal Shock Liq. To liq. 15 cycles	Frequency Output waveform
MIL-STD-202	Method 105 COND. B	Altitude, 3.44 inch Hg. 12 hrs	Frequency Output waveform
MIL-STD-883	Method 1004	Moisture resist. with supply voltage applied 25°C to 65°C, 90 to 100% RH, 10 cycles	Frequency Output waveform
MIL-STD-202	Method 210 COND. A	Resistance to Solder Heat Immersion @350°C 3.5 sec	Frequency Output waveform

C. Subgroups 3: 4 pcs. (One half of Subgroup 1)

<u>Standard</u>	<u>Condition</u>	<u>Description</u>	<u>End point Measurement</u>
	Storage Temp. No. Oper	24 hrs. @ -55°C 24 hrs. @ 125°C	Frequency Output waveform
MIL-STD-883	Method 1009 COND. A	Salt Atmosphere 24 hrs. @ 35°C 0.5-3.0% Solution	Frequency Output waveform Visual
MIL-STD-883	Method 1014 COND. A	Fine Leak	Qs <5 X10 ⁻⁸
MIL-STD-883	Method 1014 COND. C	Gross Leak	Visual in 125°C Detector fluid

Test data is available for additional cost.