



## 2N6285 – 2N6286 – 2N6287

### PNP DARLINGTON POWER SILICON TRANSISTOR

The 2N6285, 2N6286 and 2N6287 are mounted in TO-3 metal package. They are designed for use in general-purpose amplifier and low-frequency switching applications.

The complementary NPN are 2N6282, 2N6283, 2N6284  
Compliance to RoHS.

#### ABSOLUTE MAXIMUM RATINGS

Symbol	Ratings		Value	Unit
$V_{CEO}$	Collector-Emitter Voltage ( $I_B=0$ )	2N6285	-60	V
		2N6286	-80	
		2N6287	-100	
$V_{CBO}$	Collector-Base Voltage ( $I_E=0$ )	2N6285	-60	V
		2N6286	-80	
		2N6287	-100	
$V_{EBO}$	Emitter-Base Voltage ( $I_C=0$ )	2N6285	-5	V
		2N6286		
		2N6287		
$I_C$	Collector Current	2N6285	-20	A
		2N6286		
		2N6287		
$I_{CM}$	Collector Peak Current	2N6285	-40	A
		2N6286		
		2N6287		
$I_B$	Base Current	2N6285	-0.5	A
		2N6286		
		2N6287		
$P_T$	Power Dissipation	@ $T_C = 25^\circ$	160	W/°C
		2N6285		
		2N6286		
$T_J$	Junction Temperature	2N6285	200	°C
		2N6286		
		2N6287		
$T_S$	Storage Temperature	2N6285	-65 to +200	°C
		2N6286		
		2N6287		

## 2N6285 – 2N6286 – 2N6287

### THERMAL CHARACTERISTICS

Symbol	Ratings	Value	Unit
$R_{thJ-C}$	Thermal Resistance Junction-Case	1.09	°C/W

### ELECTRICAL CHARACTERISTICS

TC=25°C unless otherwise noted

Symbol	Ratings	Test Condition(s)	Min	Typ	Max	Unit	
$V_{CEO(SUS)}$	Collector-Emitter Breakdown Voltage (*)	$I_C = -200 \text{ mA}$ $I_B = 0$	2N6285	-60	-	-	V
			2N6286	-80	-	-	
			2N6287	-100	-	-	
$I_{CEO}$	Collector Cutoff Current	$V_{CE} = -30 \text{ V}, I_B = 0$	2N6285	-	-	-1	mA
		$V_{CE} = -40 \text{ V}, I_B = 0$	2N6286				
		$V_{CE} = -50 \text{ V}, I_B = 0$	2N6287				
$I_{EBO}$	Emitter Cutoff Current	$V_{BE} = -5 \text{ V}, I_C = 0$	2N6285	-	-	-2	mA
			2N6286				
			2N6287				
$I_{CEX}$	Collector Cutoff Current	$V_{CE} = -60 \text{ V}, V_{BE} = 1.5 \text{ V}$	2N6285	-	-	-500	$\mu\text{A}$
		$V_{CE} = -80 \text{ V}, V_{BE} = 1.5 \text{ V}$	2N6286				
		$V_{CE} = -100 \text{ V}, V_{BE} = 1.5 \text{ V}$	2N6287				
		$V_{CE} = 60 \text{ V}, V_{BE} = 1.5 \text{ V}$ $T_C = 150^\circ\text{C}$	2N6285	-	-	-5	mA
		$V_{CE} = -80 \text{ V}, V_{BE} = 1.5 \text{ V}$ $T_C = 150^\circ\text{C}$	2N6286				
		$V_{CE} = -100 \text{ V}, V_{BE} = 1.5 \text{ V}$ $T_C = 150^\circ\text{C}$	2N6287				
$V_{CE(SAT)}$	Collector-Emitter saturation Voltage (*)	$I_C = -10 \text{ A}, I_B = -40 \text{ mA}$	2N6285	-	-	-2	V
			2N6286				
			2N6287				
$V_{CE(SAT)}$	Collector-Emitter saturation Voltage (*)	$I_C = -20 \text{ A}, I_B = -200 \text{ mA}$	2N6285	-	-	-3	V
			2N6286				
			2N6287				
$V_{BE(SAT)}$	Base-Emitter saturation Voltage (*)	$I_C = -20 \text{ A}, I_B = -200 \text{ mA}$	2N6285	-	-	-4	V
			2N6286				
			2N6287				
$V_{BE}$	Base-Emitter Voltage (*)	$V_{CE} = -3 \text{ V}, I_C = -10 \text{ A}$	2N6285	-	-	-2,8	V
			2N6286				
			2N6287				

## 2N6285 – 2N6286 – 2N6287

Symbol	Ratings	Test Condition(s)	Min	Typ	Max	Unit	
$h_{FE}$	DC Current Gain (*)	$V_{CE} = -3\text{ V}, I_C = -10\text{ A}$	2N6285	750	-	18000	-
			2N6286				
			2N6287				
		$V_{CE} = -3\text{ V}, I_C = -20\text{ A}$	2N6285	100	-	-	
			2N6286				
			2N6287				
$C_{OB}$	Output Capacitance	$I_E = 0\text{ A}, V_{CB} = -10\text{ V}$ $f = 1\text{ MHz}$	2N6285	-	-	400	pF
			2N6286				
			2N6287				

(\*) Pulse Width  $\approx 300\ \mu\text{s}$ , Duty Cycle  $\leq 2.0\%$

### MECHANICAL DATA CASE TO-3

DIMENSIONS (mm)		
	min	max
A	11	13.10
B	0.97	1.15
C	1.5	1.65
D	8.32	8.92
F	19	20
G	10.70	11.1
N	16.50	17.20
P	25	26
R	4	4.09
U	38.50	39.30
V	30	30.30

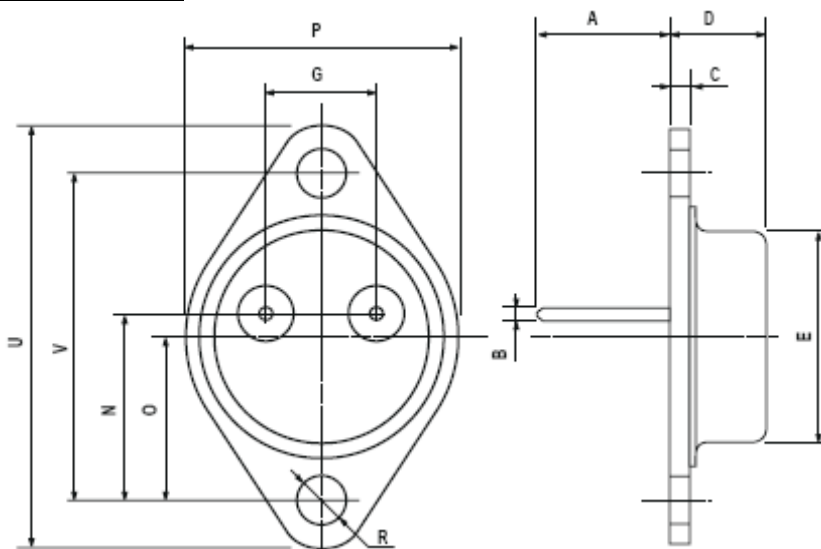

Pin 1 :	Base
Pin 2 :	Emitter
Case :	Collector

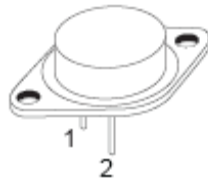

Revised August 2012

Information furnished is believed to be accurate and reliable. However, Comset Semiconductors assumes no responsibility for the consequences of use of such information nor for any infringement of patents or other rights of third parties which may result from its use. Data are subject to change without notice. Comset Semiconductors makes no warranty, representation or guarantee regarding the suitability of its products for any particular purpose, nor does Comset Semiconductors assume any liability arising out of the application or use of any product and specifically disclaims any and all liability, including without limitation consequential or incidental damages. Comset Semiconductors' products are not authorized for use as critical components in life support devices or systems.