



BDV65-A-B-C

NPN SILICON DARLINGTONS POWER TRANSISTORS

They are silicon epitaxial base transistors mounted in TO-3PN.
 They are designed for audio output stages and general amplifier and switching applications.
 complementary is BDV64-A- B-C
 Compliance to RoHS.

ABSOLUTE MAXIMUM RATINGS

Symbol	Ratings	Value	Unit	
V_{CEO}	Collector-Emitter Voltage	BDV65	60	V
		BDV65A	80	
		BDV65B	100	
		BDV65C	120	
V_{CBO}	Collector-Base Voltage	BDV65	60	V
		BDV65A	80	
		BDV65B	100	
		BDV65C	120	
V_{EBO}	Emitter-Base Voltage	BDV65	5.0	V
		BDV65A		
		BDV65B		
		BDV65C		
I_C	Collector Current	BDV65	12	A
		BDV65A		
		BDV65B		
		BDV65C		
I_{CM}	Collector Peak Current	BDV65	15	A
		BDV65A		
		BDV65B		
		BDV65C		
I_B	Base Current	BDV65	0.5	A
		BDV65A		
		BDV65B		
		BDV65C		



BDV65-A-B-C

ABSOLUTE MAXIMUM RATINGS

Symbol	Ratings		Value	Unit	
P _T	Power Dissipation	T _{mb} = 25°C	BDV65	125	Watts
			BDV65A		
			BDV65B		
			BDV65C		
		T _{mb} = 25°C	BDV65	3.5	
			BDV65A		
			BDV65B		
			BDV65C		
T _J	Junction Temperature	BDV65	150	°C	
		BDV65A			
		BDV65B			
		BDV65C			
T _s	Storage Temperature	BDV65	-65 to +150		
		BDV65A			
		BDV65B			
		BDV65C			

THERMAL CHARACTERISTICS

Symbol	Ratings		Value	Unit
R _{thj-c}	Thermal Resistance, Junction to Case	BDV65	1	°C / W
		BDV65A		
		BDV65B		
		BDV65C		
R _{thj-a}	Thermal Resistance, Junction to Ambient	BDV65	35.7	
		BDV65A		
		BDV65B		
		BDV65C		

BDV65-A-B-C

ELECTRICAL CHARACTERISTICS

TC=25°C unless otherwise noted

Symbol	Ratings	Test Condition(s)		Min	Typ	Mx	Unit	
I_{CEO}	Collector Cutoff Current	$V_{CE}= 30\text{ V}, I_B= 0$	BDV65	-	-	2	mA	
		$V_{CE}= 40\text{ V}, I_B= 0$	BDV65A					
		$V_{CE}= 50\text{ V}, I_B= 0$	BDV65B					
		$V_{CE}= 60\text{ V}, I_B= 0$	BDV65C					
I_{EBO}	Emitter Cutoff Current	$V_{BE}= 5\text{ V}, I_C= 0$	BDV65	-	-	5	mA	
			BDV65A					
			BDV65B					
			BDV65C					
I_{CBO}	Collector Cutoff Current	$I_E= 0$ $T_j=25^\circ\text{C}$	$V_{CB}= 60\text{ V}$	BDV65	-	-	0.4	mA
			$V_{CB}= 80\text{ V}$	BDV65A				
			$V_{CB}= 100\text{ V}$	BDV65B				
			$V_{CB}= 120\text{ V}$	BDV65C				
		$I_E= 0$ $T_j=150^\circ\text{C}$	$V_{CB}= 30\text{ V}$	BDV65	-	-	2	
			$V_{CB}= 40\text{ V}$	BDV65A				
			$V_{CB}= 50\text{ V}$	BDV65B				
			$V_{CB}= 60\text{ V}$	BDV65C				
V_{CEO}	Collector-Emitter Breakdown Voltage (*)	$I_C= 30\text{ mA}, I_B= 0$	BDV65	60	-	-	V	
			BDV65A	80	-	-		
			BDV65B	100	-	-		
			BDV65C	120	-	-		
h_{FE}	DC Current Gain (*)	$V_{CE}= 4\text{ V}, I_C= 5\text{ A}$	BDV65	1000	-	-	-	
			BDV65A					
			BDV65B					
			BDV65C					
$V_{CE(SAT)}$	Collector-Emitter saturation Voltage (*)	$I_C= 5\text{ A}, I_B= 20\text{ mA}$	BDV65	-	-	2	V	
			BDV65A					
			BDV65B					
			BDV65C					
V_{BE}	Base-Emitter Voltage(*)	$V_{CE}= 4\text{ V}, I_C= 5\text{ A}$	BDV65	-	-	2,5	V	
			BDV65A					
			BDV65B					
			BDV65C					

(*) Pulse Width $\approx 300\ \mu\text{s}$, Duty Cycle $\angle 1.5\%$

BDV65-A-B-C

MECHANICAL DATA CASE TO3PN Non Isolated Plastic Package

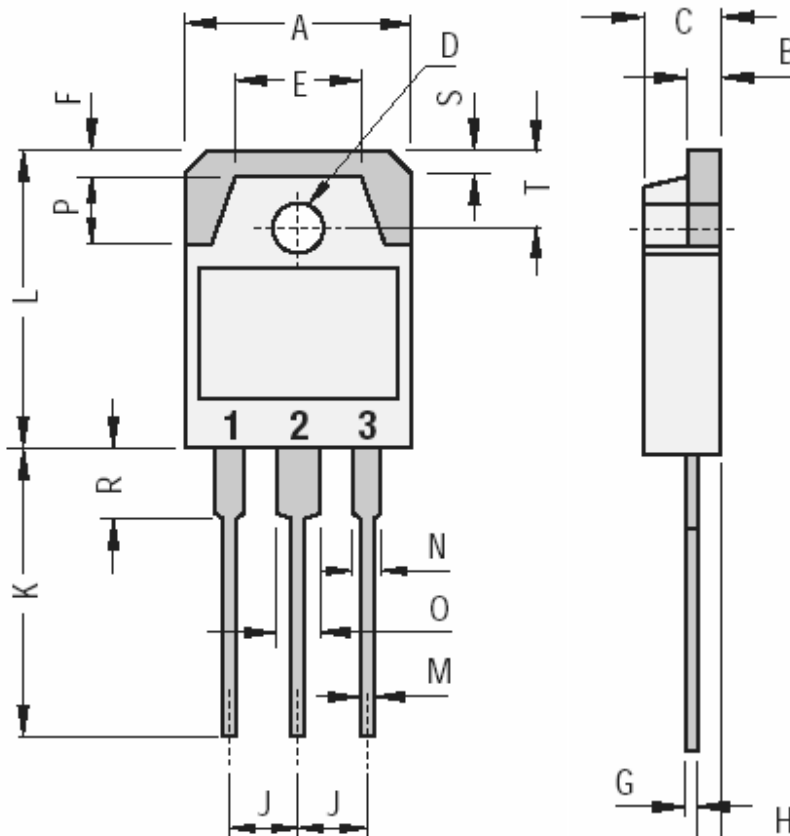

DIMENSIONS (mm)		
	Min.	Max.
A	15.20	1600
B	1.90	2.10
C	4.60	5.00
D	3.10	3.30
E		9.60
F		2.00
G	0.35	0.55
H		1.40
J	5.35	5.55
K	20.00	
L	19.60	20.20
M	0.95	1.25
N		2.00
O		3.00
P		4.00
R		4.00
S		1.80
T	4.80	5.20

Pin 1 :	Base
Pin 2 :	Collector
Pin 3 :	Emitter
Package	Collector

Revised August 2012

Information furnished is believed to be accurate and reliable. However, Comset Semiconductors assumes no responsibility for the consequences of use of such information nor for any infringement of patents or other rights of third parties which may result from its use. Data are subject to change without notice. Comset Semiconductors makes no warranty, representation or guarantee regarding the suitability of its products for any particular purpose, nor does Comset Semiconductors assume any liability arising out of the application or use of any product and specifically disclaims any and all liability, including without limitation consequential or incidental damages. Comset Semiconductors' products are not authorized for use as critical components in life support devices or systems.