



## NPN BD433 – BD435 – BD437

### SILICON NPN POWER TRANSISTORS.

The BD433-BD435-BD437 are NPN Transistors mounted in Jedec TO-126 plastic package. They are recommended for use in medium power linear and switching applications. PNP complements are BD434-BD436-BD438. Compliance to RoHS.

#### ABSOLUTE MAXIMUM RATINGS

Symbol	Ratings	Value	Unit	
$V_{CBO}$	Collector-Base Voltage ( $I_E = 0$ )	BD433	22	V
		BD435	32	
		BD437	45	
$V_{CEO}$	Collector-Emitter Voltage ( $I_B = 0$ )	BD433	22	V
		BD435	32	
		BD437	45	
$V_{EBO}$	Emitter-Base Voltage ( $I_C = 0$ )	5	V	
$I_C$	Collector Current	4	A	
$I_{CM}$	Collector Current Peak	7		
$I_B$	Base Current	1	A	
$P_C$	Total power Dissipation	$T_C = 25^\circ\text{C}$	36	W
$T_J$	Junction Temperature		150	$^\circ\text{C}$
$T_{Stg}$	Storage Temperature		-65 to +150	$^\circ\text{C}$

#### THERMAL CHARACTERISTICS

Symbol	Ratings	Value	Unit
$R_{thJ-c}$	Thermal Resistance, Junction-Case	3.5	$^\circ\text{C}/\text{W}$
$R_{thJ-a}$	Thermal Resistance, Junction-ambient in free air	100	$^\circ\text{C}/\text{W}$

## NPN BD433 – BD435 – BD437

### ELECTRICAL CHARACTERISTICS

TC=25°C unless otherwise noted

Symbol	Ratings	Test Condition(s)		Min	Typ	Max	Unit
$I_{CBO}$	Collector cut-off current	$I_E = 0, V_{CB} = 22\text{ V}$	BD433	-	-	100	$\mu\text{A}$
		$I_E = 0, V_{CB} = 32\text{ V}$	BD435				
		$I_E = 0, V_{CB} = 45\text{ V}$	BD437				
$I_{CES}$	Collector cut-off current	$V_{BE} = 0, V_{CE} = 22\text{ V}$	BD433	-	-	100	$\mu\text{A}$
		$V_{BE} = 0, V_{CE} = 32\text{ V}$	BD435				
		$V_{BE} = 0, V_{CE} = 45\text{ V}$	BD437				
$I_{EBO}$	Emitter cut-off current	$I_C = 0$ $V_{EB} = 5\text{ V}$	BD433	-	-	1	mA
			BD435				
			BD437				
$V_{CEO(SUS)}$	Collector-Emitter sustaining Voltage (*)	$I_B = 0$ $I_C = 100\text{ mA}$	BD433	22	-	-	V
			BD435	32	-	-	
			BD437	45	-	-	
$V_{CE(SAT)}$	Collector-Emitter saturation Voltage (*)	$I_C = 2\text{ A}$ $I_B = 200\text{ mA}$	BD433	-	-	0.5	V
			BD435			0.6	
			BD437				
$V_{BE}$	Base-Emitter Voltage(*)	$I_C = 2\text{ A}$ $V_{CE} = 1\text{ V}$	BD433	-	-	1.1	V
			BD435			1.2	
			BD437				
$h_{FE}$	DC Current Gain (*)	$I_C = 10\text{ mA}$ $V_{CE} = 5\text{ V}$	BD433	40	130	-	-
			BD435				
			BD437			30	
		$I_C = 500\text{ mA}$ $V_{CE} = 1\text{ V}$	BD433	85	140	-	
			BD435				
			BD437				
		$I_C = 2\text{ A}$ $V_{CE} = 1\text{ V}$	BD433	50	-	-	
			BD435				
			BD437			40	
$f_T$	Transition frequency	$I_C = 250\text{ mA}$ $V_{CE} = 1\text{ V}$	BD433	3	-	-	MHz
			BD435				
			BD437				

1. Measured under pulse conditions :  $t_P < 300\mu\text{s}$ ,  $\delta < 1.5$

## NPN BD433 – BD435 – BD437

### MECHANICAL DATA CASE TO-126

	DIMENSIONS	
	min	max
A	7.4	7.8
B	10.5	10.8
C	2.4	2.7
D	0.7	0.9
E	2.25 typ.	
F	0.49	0.75
G	4.4 typ.	
L	15.7 typ.	
M	1.27 typ.	
N	3.75 typ.	
P	3.0	3.2
S	2.54 typ.	

Pin 1 :	Emitter
Pin 2 :	Collector
Pin 3 :	Base

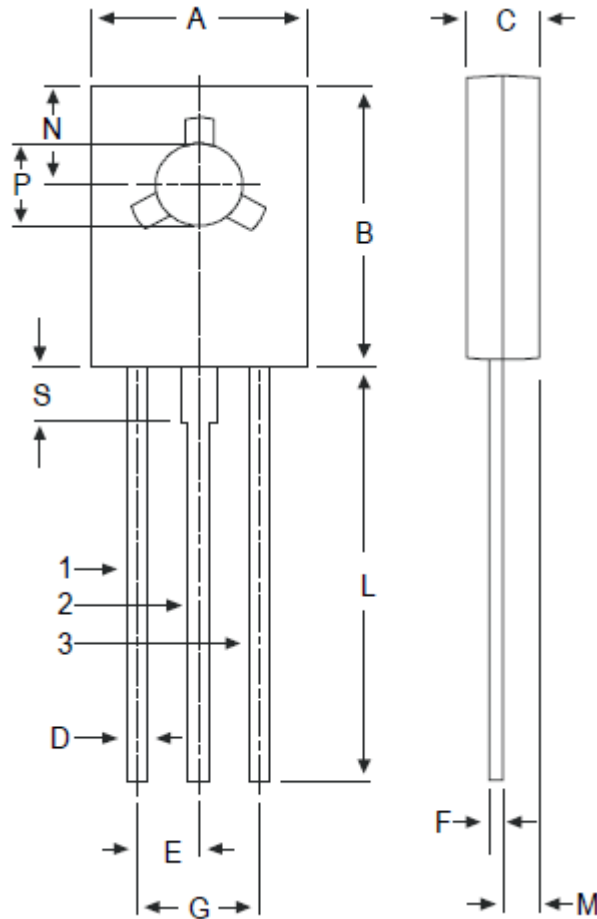

Revised August 2014

Information furnished is believed to be accurate and reliable. However, Comset Semiconductors assumes no responsibility for the consequences of use of such information nor for any infringement of patents or other rights of third parties which may result from its use. Data are subject to change without notice. Comset Semiconductors makes no warranty, representation or guarantee regarding the suitability of its products for any particular purpose, nor does Comset Semiconductors assume any liability arising out of the application or use of any product and specifically disclaims any and all liability, including without limitation consequential or incidental damages. Comset Semiconductors' products are not authorized for use as critical components in life support devices or systems.