



BDY23 – 180T2
BDY24 – 181T2
BDY25 – 182T2

NPN SILICON TRANSISTORS, DIFFUSED MESA

They are NPN transistors mounted in Jedec TO-3.
 LF Large Signal Power Amplification.
 High Current Fast Switching.
 Compliance to RoHS.

ABSOLUTE MAXIMUM RATINGS

Symbol	Ratings	Value	Unit	
V_{CEO}	Collector-Emitter Voltage	BDY23, 180T2	60	V
		BDY24, 181T2	90	
		BDY25, 182T2	140	
V_{CBO}	Collector-Base Voltage	BDY23, 180T2	60	V
		BDY24, 181T2	100	
		BDY25, 182T2	200	
V_{EBO}	Emitter-Base Voltage	BDY23, 180T2 BDY24, 181T2 BDY25, 182T2	10	V
I_C	Collector Current	BDY23, 180T2 BDY24, 181T2 BDY25, 182T2	6	A
I_B	Base Current	BDY23, 180T2 BDY24, 181T2 BDY25, 181T2	3	A
P_{TOT}	Power Dissipation	@ $T_C = 25^\circ$	87.5	Watts
T_J	Junction Temperature		-65 to +200	°C
T_S	Storage Temperature			

THERMAL CHARACTERISTICS

Symbol	Ratings	Value	Unit
R_{thJ-C}	Thermal Resistance, Junction to Case	2	°C/W

**BDY23 – 180T2
BDY24 – 181T2
BDY25 – 182T2**
ELECTRICAL CHARACTERISTICS

TC=25°C unless otherwise noted

Symbol	Ratings	Test Condition(s)	Min	Typ	Max	Unit	
$V_{CEO(BR)}$	Collector-Emitter Breakdown Voltage (*)	$I_C=50\text{ mA}$ $I_B=0$	BDY23, 180T2	60	-	-	V
			BDY24, 181T2	80	-	-	
			BDY25, 182T2	140	-	-	
I_{CEO}	Collector-Emitter Cutoff Current	$V_{CE}=60\text{ V}$	BDY23	-	-	1.0	mA
		$V_{CE}=90\text{ V}$	BDY24	-	-		
		$V_{CE}=140\text{ V}$	BDY25	-	-		
I_{EBO}	Emitter-Base Cutoff Current	$V_{EB}=10\text{ V}$	BDY23, 180T2	-	-	1.0	mA
			BDY24, 181T2				
			BDY25, 182T2				
I_{CES}	Collector-Emitter Cutoff Current	$V_{CE}=60\text{ V}$ $V_{BE}=0\text{ V}$	BDY23, 180T2	-	-	0.5	mA
		$V_{CE}=100\text{ V}$ $V_{BE}=0\text{ V}$	BDY24, 181T2	-	-	1.0	
		$V_{CE}=180\text{ V}$ $V_{BE}=0\text{ V}$	BDY25, 182T2	-	-	1.0	
$V_{CE(SAT)}$	Collector-Emitter saturation Voltage (*)	$I_C=2.0\text{ A}$, $I_B=0.25\text{ A}$	BDY23, 180T2	-	-	1	V
			BDY24, 181T2	-	-	0.6	
			BDY25, 182T2	-	-	0.6	
$V_{(BR)CBO}$	Collector-Base Breakdown Voltage (*)	$I_C=3\text{ mA}$	BDY23, 180T2	60	-	-	V
			BDY24, 181T2	100	-	-	
			BDY25, 182T2	200	-	-	
$V_{BE(SAT)}$	Base-Emitter Voltage (*)	$I_C=2.0\text{ A}$, $I_B=0.25\text{ A}$	BDY23, 180T2	-	-	2.0	V
			BDY24, 181T2	-	-	1.2	
			BDY25, 182T2	-	-	1.2	
h_{21E}	Static Forward Current transfer ratio (*)	$V_{CE}=4\text{ V}$ $I_C=1\text{ A}$	A	-	55	-	-
			B	-	65	-	
			C	-	90	-	
		$V_{CE}=4\text{ V}$ $I_C=2\text{ A}$	A	15	20	45	
			B	30	45	90	
			C	75	82	100	
f_T	Transition Frequency	$V_{CE}=15\text{ V}$, $I_C=0.5\text{ A}$, $f=10\text{ MHz}$	10	-	-	MHz	
$t_d + t_r$	Turn-on time	$I_C=5\text{ A}$, $I_B=1\text{ A}$	-	0.3	0.5	μs	
$t_s + t_f$	Turn-off time	$I_C=5\text{ A}$, $I_{B1}=1\text{ A}$, $I_{B2}=-0.5\text{ A}$	-	0.3	0.5	μs	

 (*) Pulse Width $\approx 300\ \mu\text{s}$, Duty Cycle $\angle 2.0\%$

BDY23 – 180T2
BDY24 – 181T2
BDY25 – 182T2

MECHANICAL DATA CASE TO-3

DIMENSIONS (mm)		
	min	max
A	11	13.10
B	0.97	1.15
C	1.5	1.65
D	8.32	8.92
F	19	20
G	10.70	11.1
N	16.50	17.20
P	25	26
R	4	4.09
U	38.50	39.30
V	30	30.30

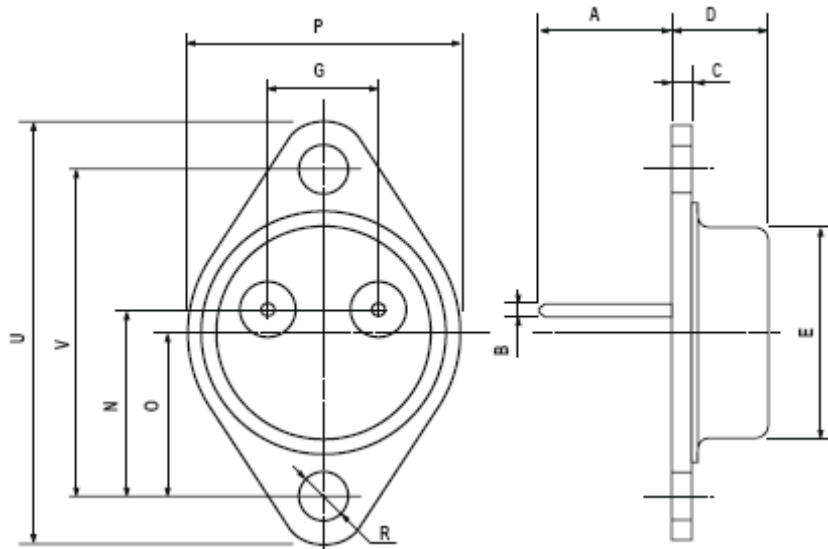

Pin 1 :	Base
Pin 2 :	Emitter
Case :	Collector

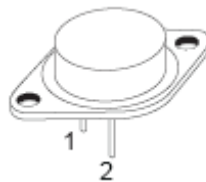

Revised September 2012

Information furnished is believed to be accurate and reliable. However, Comset Semiconductors assumes no responsibility for the consequences of use of such information nor for any infringement of patents or other rights of third parties which may result from its use. Data are subject to change without notice. Comset Semiconductors makes no warranty, representation or guarantee regarding the suitability of its products for any particular purpose, nor does Comset Semiconductors assume any liability arising out of the application or use of any product and specifically disclaims any and all liability, including without limitation consequential or incidental damages. Comset Semiconductors' products are not authorized for use as critical components in life support devices or systems.