



2N4901 – 2N4902 – 2N4903

PNP SILICON TRANSISTORS, EPITAXIAL BASE

The 2N4901, 2N4902, 2N4903 are mounted in Jedec TO-3 metal case. They are intended for general-purpose switching and power amplifier applications. Compliance to RoHS.

ABSOLUTE MAXIMUM RATINGS

Symbol	Ratings		Value	Unit	
V_{CBO}	Collector to Base Voltage	2N4901	-40	V	
		2N4902	-60		
		2N4903	-80		
V_{CEO}	#Collector-Emitter Voltage	2N4901	-40	V	
		2N4902	-60		
		2N4903	-80		
V_{CER}	Collector-Emitter Voltage	2N4901	-40	V	
		2N4902	-60		
		2N4903	-80		
V_{EBO}	Emitter-Base Voltage		-5	V	
V_{CEX}	Collector-Base Voltage	$V_{BE}=1.5\text{ V}$	2N4901	-40	V
			2N4902	-60	
			2N4903	-80	
I_C	Collector Current – Continuous		-5	A	
I_{CM}	Collector Current – Peak	$t_p=5\text{ ms}$	-10	A	
I_B	Base Current – Continuous		-1	A	
P_{TOT}	Power Dissipation		87.5	W	
T_J	Junction Temperature		200	°C	
T_{STG}	Storage Temperature		-65 to +200	°C	

THERMAL CHARACTERISTICS

Symbol	Ratings	Value	Unit
R_{thJC}	Thermal Resistance, Junction to Case	2	°C/W
R_{thJA}	Junction to Free Air Thermal Resistance	43.7	°C/W



2N4901 – 2N4902 – 2N4903

ELECTRICAL CHARACTERISTICS

TC=25°C unless otherwise noted

Symbol	Ratings	Test Condition(s)	Min	Typ	Mx	Unit	
$V_{CEO(sus)}$	Collector-Emitter Sustaining Voltage	$I_C=200\text{ mA}_{dc}$, $I_B=0$	2N4901	-40	-	-	V
			2N4902	-60			
			2N4903	-80			
I_{CBO}	Collector-Base cut-off Current	$V_{CE}=-40\text{ V}$, $I_E=0$	2N4901	-	-	-0.1	mA
		$V_{CE}=-60\text{ V}$, $I_E=0$	2N4902	-	-	-0.1	
		$V_{CE}=-80\text{ V}$, $I_E=0$	2N4903	-	-	-0.1	
I_{CEO}	Collector cut-off Current	$V_{CE}=-40\text{ V}$, $I_B=0$	2N4901	-	-	-1	mA
		$V_{CE}=-60\text{ V}$, $I_B=0$	2N4902	-	-	-1	
		$V_{CE}=-80\text{ V}$, $I_B=0$	2N4903	-	-	-1	
I_{CEX}	Collector Cutoff Current	$V_{CE}=-40\text{ V}$, $V_{EB}=1.5\text{ V}$	2N4901	-	-	-0.1	mA
		$V_{CE}=-40\text{ V}$, $V_{EB}=1.5\text{ V}$ $T_{CASE}=150^\circ\text{C}$		-	-	-2.0	
		$V_{CE}=-60\text{ V}$, $V_{EB}=1.5\text{ V}$	2N4902	-	-	-0.1	
		$V_{CE}=-60\text{ V}$, $V_{EB}=1.5\text{ V}$ $T_{CASE}=150^\circ\text{C}$		-	-	-2.0	
		$V_{CE}=-80\text{ V}$, $V_{EB}=1.5\text{ V}$	2N4903	-	-	-0.1	
		$V_{CE}=-80\text{ V}$, $V_{EB}=1.5\text{ V}$ $T_{CASE}=150^\circ\text{C}$		-	-	-2.0	
I_{EBO}	Emitter Cutoff Current	$V_{BE}=5.0\text{ V}$, $I_C=0$	2N4901	-	-	-1.0	mA
			2N4902				
			2N4903				
h_{FE}	DC Current Gain (*)	$V_{CE}=-2.0\text{ V}$, $I_C=-1.0\text{ A}$	2N4901	20	-	80	V
			2N4902				
			2N4903				
		$V_{CE}=-2.0\text{ V}$, $I_C=-5.0\text{ A}$	2N4901	7	-	-	
			2N4902				
			2N4903				
$V_{CE(SAT)}$	Collector-Emitter saturation Voltage (*)	$I_C=-1.0\text{ A}$, $I_B=-0.1\text{ A}$	2N4901	-	-	-0.4	V
			2N4902				
			2N4903				
		$I_C=-5.0\text{ A}$, $I_B=-1.0\text{ A}$	2N4901	-	-	-1.5	
			2N4902				
			2N4903				
V_{BE}	Base-Emitter Voltage (*)	$I_C=-1.0\text{ A}$, $V_{CE}=-2.0\text{ V}$	2N4901	-	-	-1.2	V
			2N4902				
			2N4903				
f_T	Transition Frequency	$V_{CE}=-10\text{ V}$, $I_C=-1\text{ A}$	2N4901	4	-	-	MHz
			2N4902				
			2N4903				

(*) Pulse Width $\approx 300\ \mu\text{s}$, Duty Cycle $\angle 2.0\%$

2N4901 – 2N4902 – 2N4903
MECHANICAL DATA CASE TO-3

DIMENSIONS (mm)		
	min	max
A	11	13.10
B	0.97	1.15
C	1.5	1.65
D	8.32	8.92
F	19	20
G	10.70	11.1
N	16.50	17.20
P	25	26
R	4	4.09
U	38.50	39.30
V	30	30.30

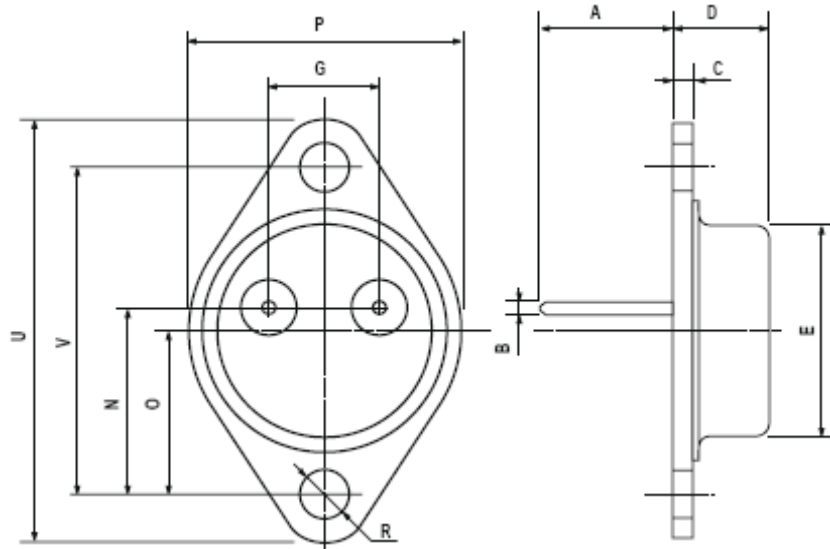

Pin 1 :	Base
Pin 2 :	Emitter
Case :	Collector

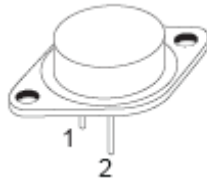

Revised January 2015

Information furnished is believed to be accurate and reliable. However, Comset Semiconductors assumes no responsibility for the consequences of use of such information nor for any infringement of patents or other rights of third parties which may result from its use. Data are subject to change without notice. Comset Semiconductors makes no warranty, representation or guarantee regarding the suitability of its products for any particular purpose, nor does Comset Semiconductors assume any liability arising out of the application or use of any product and specifically disclaims any and all liability, including without limitation consequential or incidental damages. Comset Semiconductors' products are not authorized for use as critical components in life support devices or systems.