

Product Specification

~40km Multi-Rate DWDM XFP Optical Transceiver

FTLX3612M3xx

PRODUCT FEATURES

- Supports 9.95Gb/s to 11.3Gb/s bit rates
- 100GHz channel spacing on the ITU C-band
- Hot-pluggable XFP footprint
- RoHS-6 Compliant (lead-free)
- Temperature-stabilized 1550nm EML transmitter
- Supports -300ps/nm to +800ps/nm
- 3.3V and 5V power supplies required
- Duplex LC connector
- Power dissipation < 3.5W
- Built-in digital diagnostic functions
- Commercial temperature range: 0°C to 70°C
- Reference clock not required



APPLICATIONS

- SONET OC-192 IR-2
SDH STM S-64.2b
SONET OC-192 IR-3
SDH STM S-64.3b
ITU-T G.709
- 10GBASE-ER/EW
10GBASE-ER/EW + FEC
- 40km 10G Fibre Channel
40km 10G Fibre Channel + FEC

Finisar's 40km DWDM FTLX3612M3xx Small Form Factor 10Gb/s XFP transceivers comply with the current XFP Multi-Source Agreement (MSA) Specification¹. They also comply with SONET OC-192 IR-2, OC-192 IR-3, SDH STM S-64.2b, STM S-64.3b as well as with 10-Gigabit Ethernet 10GBASE-ER/EW per IEEE 802.3ae and 40km 10G Fibre Channel applications. Digital diagnostics functions are available via a 2-wire serial interface, as specified in the XFP MSA. The transceiver is RoHS compliant and lead free per Directive 2002/95/EC³, and Finisar Application Note AN-2038⁴.

PRODUCT SELECTION

FTLX3612M3xx

xx: 100GHz ITU Grid wavelength (see next page)

Channel #	Product Code	Frequency (THz)	Center Wavelength (nm)
15*	FTLX3612M315	191.5	1565.50
16*	FTLX3612M316	191.6	1564.68
17*	FTLX3612M317	191.7	1563.86
18*	FTLX3612M318	191.8	1563.05
19	FTLX3612M319	191.9	1562.23
20	FTLX3612M320	192.0	1561.42
21	FTLX3612M321	192.1	1560.61
22	FTLX3612M322	192.2	1559.79
23	FTLX3612M323	192.3	1558.98
24	FTLX3612M324	192.4	1558.17
25	FTLX3612M325	192.5	1557.36
26	FTLX3612M326	192.6	1556.55
27	FTLX3612M327	192.7	1555.75
28	FTLX3612M328	192.8	1554.94
29	FTLX3612M329	192.9	1554.13
30	FTLX3612M330	193.0	1553.33
31	FTLX3612M331	193.1	1552.52
32	FTLX3612M332	193.2	1551.72
33	FTLX3612M333	193.3	1550.92
34	FTLX3612M334	193.4	1550.12
35	FTLX3612M335	193.5	1549.32
36	FTLX3612M336	193.6	1548.51
37	FTLX3612M337	193.7	1547.72
38	FTLX3612M338	193.8	1546.92
39	FTLX3612M339	193.9	1546.12
40	FTLX3612M340	194.0	1545.32
41	FTLX3612M341	194.1	1544.53
42	FTLX3612M342	194.2	1543.73
43	FTLX3612M343	194.3	1542.94
44	FTLX3612M344	194.4	1542.14
45	FTLX3612M345	194.5	1541.35
46	FTLX3612M346	194.6	1540.56
47	FTLX3612M347	194.7	1539.77
48	FTLX3612M348	194.8	1538.98
49	FTLX3612M349	194.9	1538.19
50	FTLX3612M350	195.0	1537.40
51	FTLX3612M351	195.1	1536.61
52	FTLX3612M352	195.2	1535.82
53	FTLX3612M353	195.3	1535.04
54	FTLX3612M354	195.4	1534.25
55	FTLX3612M355	195.5	1533.47
56	FTLX3612M356	195.6	1532.68
57	FTLX3612M357	195.7	1531.90
58	FTLX3612M358	195.8	1531.12
59	FTLX3612M359	195.9	1530.33
60	FTLX3612M360	196.0	1529.55
61*	FTLX3612M361	196.1	1528.77

*Note** → Please contact your Finisar representative for non-standard channels indicated with an “*”.

I. Pin Descriptions

Pin	Logic	Symbol	Name/Description	Ref.
1		GND	Module Ground	1
2		VEE5	Optional –5.2 Power Supply – Not required	
3	LVTTL-I	Mod-Desel	Module De-select; When held low allows the module to respond to 2-wire serial interface commands	
4	LVTTL-O	Interrupt	Interrupt (bar); Indicates presence of an important condition which can be read over the serial 2-wire interface	2
5	LVTTL-I	TX_DIS	Transmitter Disable; Transmitter laser source turned off	
6		VCC5	+5 Power Supply	
7		GND	Module Ground	1
8		VCC3	+3.3V Power Supply	
9		VCC3	+3.3V Power Supply	
10	LVTTL-I	SCL	Serial 2-wire interface clock	2
11	LVTTL-I/O	SDA	Serial 2-wire interface data line	2
12	LVTTL-O	Mod_Abs	Module Absent; Indicates module is not present. Grounded in the module.	2
13	LVTTL-O	Mod_NR	Module Not Ready; Finisar defines it as a logical OR between RX_LOS and Loss of Lock in TX/RX.	2
14	LVTTL-O	RX_LOS	Receiver Loss of Signal indicator	2
15		GND	Module Ground	1
16		GND	Module Ground	1
17	CML-O	RD-	Receiver inverted data output	
18	CML-O	RD+	Receiver non-inverted data output	
19		GND	Module Ground	1
20		VCC2	+1.8V Power Supply – Not Required	
21	LVTTL-I	P_Down/RST	Power Down; When high, places the module in the low power stand-by mode and on the falling edge of P_Down initiates a module reset Reset; The falling edge initiates a complete reset of the module including the 2-wire serial interface, equivalent to a power cycle.	
22		VCC2	+1.8V Power Supply – Not Required	
23		GND	Module Ground	1
24	PECL-I	RefCLK+	Reference Clock non-inverted input, AC coupled on the host board – Not required	
25	PECL-I	RefCLK-	Reference Clock inverted input, AC coupled on the host board – Not required	
26		GND	Module Ground	1
27		GND	Module Ground	1
28	CML-I	TD-	Transmitter inverted data input	
29	CML-I	TD+	Transmitter non-inverted data input	
30		GND	Module Ground	1

Notes:

1. Module circuit ground is isolated from module chassis ground within the module.
2. Open collector; should be pulled up with 4.7k – 10kohms on host board to a voltage between 3.15V and 3.6V.

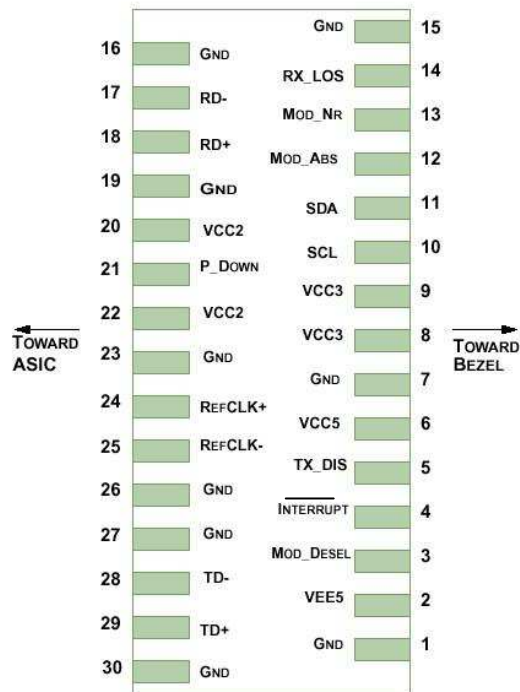

Diagram of Host Board Connector Block Pin Numbers and Names

II. Absolute Maximum Ratings

Parameter	Symbol	Min	Typ	Max	Unit	Ref.
Maximum Supply Voltage 1	Vcc3	-0.5		4.0	V	
Maximum Supply Voltage 2	Vcc5	-0.5		6.0	V	
Storage Temperature	T _S	-40		85	°C	
Case Operating Temperature	T _{OP}	-5		70	°C	

III. Electrical Characteristics (T_{OP} = -5 to 70 °C, V_{CC5} = 4.75 to 5.25 Volts)

Parameter	Symbol	Min	Typ	Max	Unit	Ref.	
Main Supply Voltage	V _{cc5}	4.75		5.25	V		
Supply Voltage #2	V _{cc3}	3.13		3.45	V		
Supply Current – V _{cc5} supply	I _{cc5}			350	mA		
Supply Current – V _{cc3} supply	I _{cc3}			750	mA		
Module total power	P			3.5	W	1	
Transmitter							
Input differential impedance	R _{in}		100		Ω	2	
Differential data input swing	V _{in,pp}	120		820	mV		
Transmit Disable Voltage	V _D	2.0		V _{cc}	V	3	
Transmit Enable Voltage	V _{EN}	GND		GND+ 0.8	V		
Transmit Disable Assert Time				10	us		
Receiver							
Differential data output swing	V _{out,pp}	340	650	850	mV	4	
Data output rise time	t _r			38	ps	5	
Data output fall time	t _f			38	ps	5	
LOS Fault	V _{LOS fault}	V _{cc} – 0.5		V _{ccHOST}	V	6	
LOS Normal	V _{LOS norm}	GND		GND+0.5	V	6	
Power Supply Rejection	PSR	See Note 6 below					7

Notes:

1. Maximum total power value is specified across the full temperature and voltage range.
2. After internal AC coupling.
3. Or open circuit.
4. Into 100 ohms differential termination.
5. 20 – 80 %
6. Loss Of Signal is open collector to be pulled up with a 4.7k – 10kohm resistor to 3.15 – 3.6V. Logic 0 indicates normal operation; logic 1 indicates no signal detected.
7. Per Section 2.7.1. in the XFP MSA Specification¹.

IV. Optical Characteristics (T_{OP} = -5 to 70°C, V_{CC5} = 4.75 to 5.25 Volts)

Please note that the Transmitter of the FTLX3612M3xx becomes operational within 5 seconds of power-up. This is due to the time required for the EML to reach its optimum operating temperature.

Parameter	Symbol	Min	Typ	Max	Unit	Ref.
Transmitter						
Output Opt. Pwr: 9/125 SMF	P _{OUT}	-1		+2	dBm	
Optical Extinction Ratio	ER	8.2			dB	
Optical Modulation Amplitude	OMA	-2.1			dBm	1
Center Wavelength Spacing			100		GHz	
Transmitter Center Wavelength – End Of Life	λ_c	X-100	X	X+100	pm	
Transmitter Center Wavelength – Beginning Of Life	λ_c	X-25	X	X+25	pm	
Transmitter Dispersion Penalty (@ 800 ps/nm)	TDP			2	dB	
Sidemode Supression ratio	SSR _{min}	30			dB	
Tx Jitter (SONET) 20kHz-80MHz	T _{Xj1}			0.3	UI	2
Tx Jitter (SONET) 4MHz – 80MHz	T _{Xj2}			0.1	UI	2
Relative Intensity Noise	RIN			-130	dB/Hz	
Receiver						
Receiver Sensitivity @ 9.95Gb/s to 10.7Gb/s	R _{SENS1}			-16	dBm	
Receiver Sensitivity @ 11.1Gb/s to 11.3Gb/s	R _{SENS2}			-15	dBm	
Stressed Receiver Sensitivity (OMA) @ 11.1Gb/s	R _{SENS2}			-11.3	dBm	
Maximum Input Power	P _{MAX}	-1			dBm	
Optical Center Wavelength	λ_c	1270		1600	nm	
Receiver Reflectance	R _{TX}			-27	dB	
Path penalty at 40km (up to 10.7Gb/s)				2	dB	3
LOS De-Assert	LOS _D			-22	dBm	
LOS Assert	LOS _A	-28			dBm	
LOS Hysteresis		0.5			dB	

Notes:

1. Guaranteed minimum OMA for 9.9Gb/s - 11.3Gb/s.
2. GR-253-CORE Issue 4
3. Dispersion penalty is measured in loopback using 18 ps/(nm*km) fiber (SMF-28). Path penalty is 2dB at 10.7Gb/s.

V. General Specifications

Parameter	Symbol	Min	Typ	Max	Units	Ref.
Bit Rate	BR	9.95		11.3	Gb/s	1
Bit Error Ratio	BER			10^{-12}		2
Max. Supported Link Length	L_{MAX}		40		km	1

Notes:

- SONET OC-192 IR-2, OC-192 IR-3, 10GBASE-ER/EW, 10G Fibre Channel, ITU-T G.709, 10GBASE-ER/EW + FEC, 10G Fibre Channel + FEC
- Tested with a $2^{31} - 1$ PRBS

VI. Environmental Specifications

The FTLX3612M3xx transceiver has an operating case temperature range from 0°C to +70°C.

Parameter	Symbol	Min	Typ	Max	Units	Ref.
Case Operating Temperature	T_{op}	-5		70	°C	
Storage Temperature	T_{sto}	-40		85	°C	

VII. Regulatory Compliance

Finisar XFP transceivers are Class 1 Laser Products. They are certified per the following standards:

Feature	Agency	Standard	Certificate Number
Laser Eye Safety	FDA/CDRH	CDRH 21 CFR 1040 and Laser Notice 50	9210176-77
Laser Eye Safety	TÜV	EN 60825-1: 1994+A11:1996+A2:2001 IEC 60825-1: 1993+A1:1997+A2:2001 IEC 60825-2: 2000, Edition 2	72101686
Electrical Safety	TÜV	EN 60950	72101686
Electrical Safety	UL/CSA	CLASS 3862.07 CLASS 3862.87	2283290

Copies of the referenced certificates are available at Finisar Corporation upon request.

VIII. Digital Diagnostics Functions

As defined by the XFP MSA¹, Finisar XFP transceivers provide digital diagnostic functions via a 2-wire serial interface, which allows real-time access to the following operating parameters:

- Transceiver temperature
- Laser bias current
- Transmitted optical power
- Received optical power
- Transceiver supply voltage

It also provides a sophisticated system of alarm and warning flags, which may be used to alert end-users when particular operating parameters are outside of a factory-set normal range.

The operating and diagnostics information is monitored and reported by a Digital Diagnostics Transceiver Controller (DDTC) inside the transceiver, which is accessed through the 2-wire serial interface. When the serial protocol is activated, the serial clock signal (SCL pin) is generated by the host. The positive edge clocks data into the XFP transceiver into those segments of its memory map that are not write-protected. The negative edge clocks data from the XFP transceiver. The serial data signal (SDA pin) is bi-directional for serial data transfer. The host uses SDA in conjunction with SCL to mark the start and end of serial protocol activation. The memories are organized as a series of 8-bit data words that can be addressed individually or sequentially. The 2-wire serial interface provides sequential or random access to the 8 bit parameters, addressed from 000h to the maximum address of the memory.

For more detailed information, including memory map definitions, please see the XFP MSA documentation¹.

IX. Mechanical Specifications

Finisar’s XFP transceivers are compliant with the dimensions defined by the XFP Multi-Sourcing Agreement (MSA).

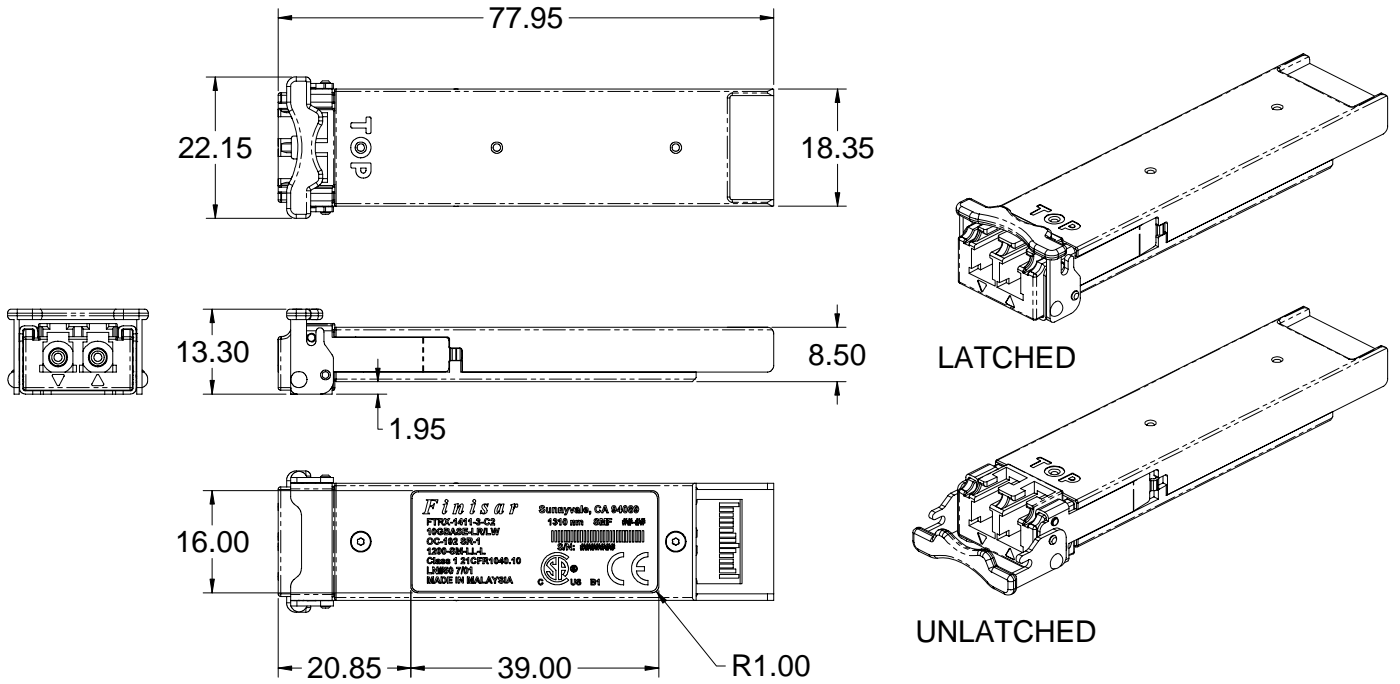

XFP Transceiver (dimensions are in mm)

X. PCB Layout and Bezel Recommendations

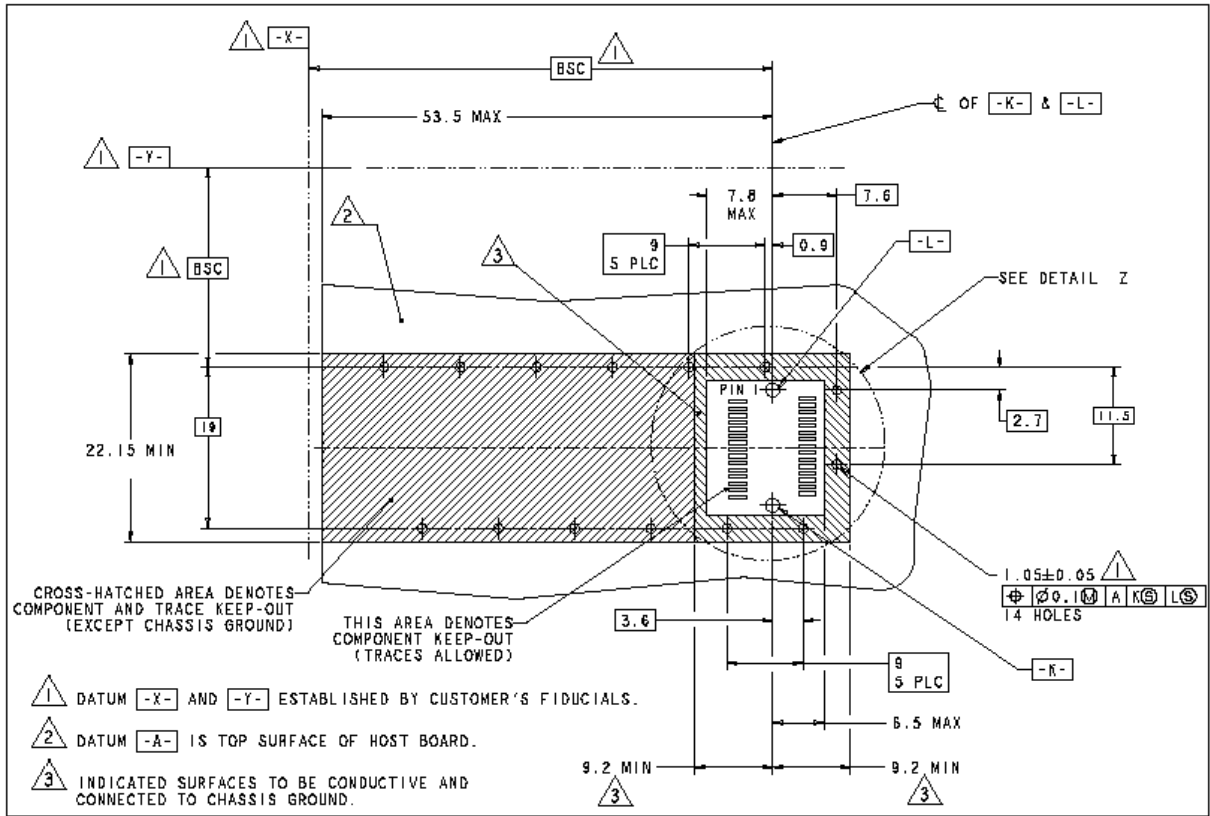

XFP Host Board Mechanical Layout (dimensions are in mm)

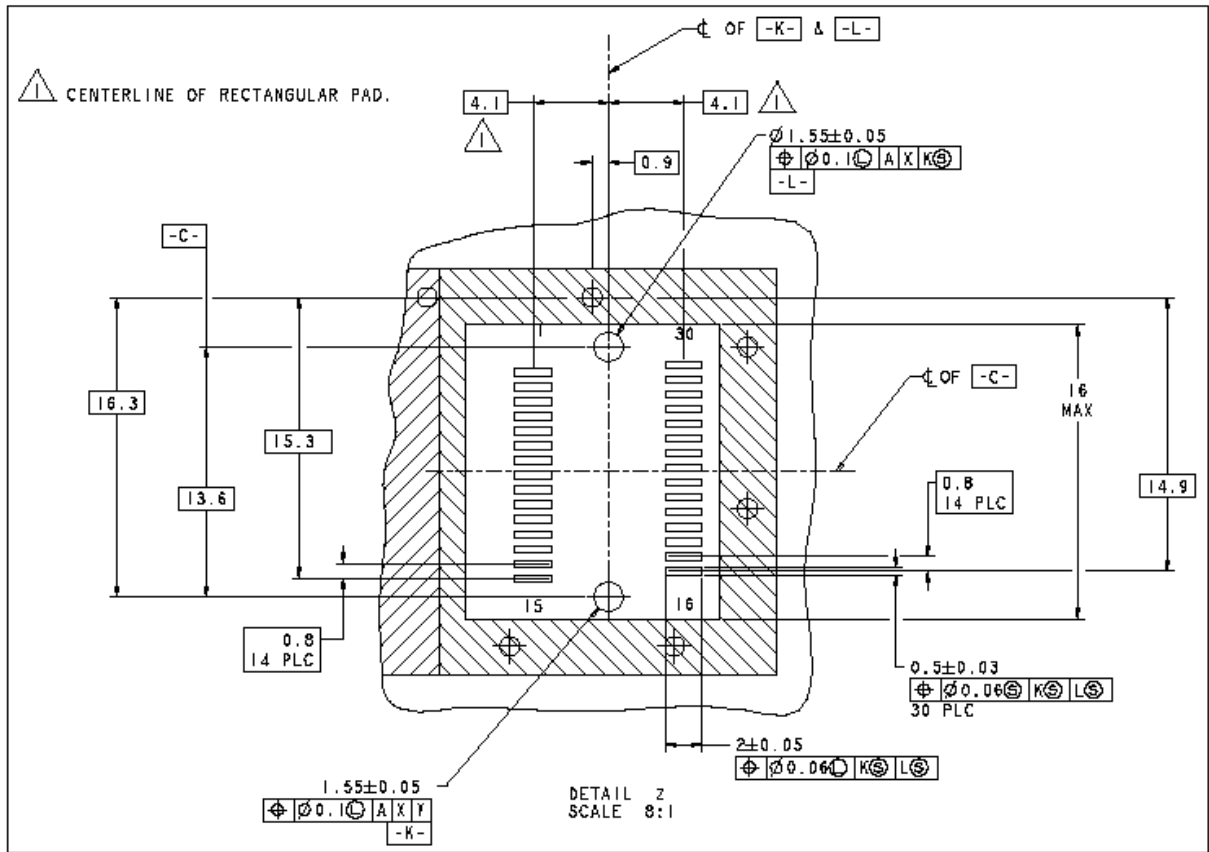

XFP Detail Host Board Mechanical Layout (dimensions are in mm)

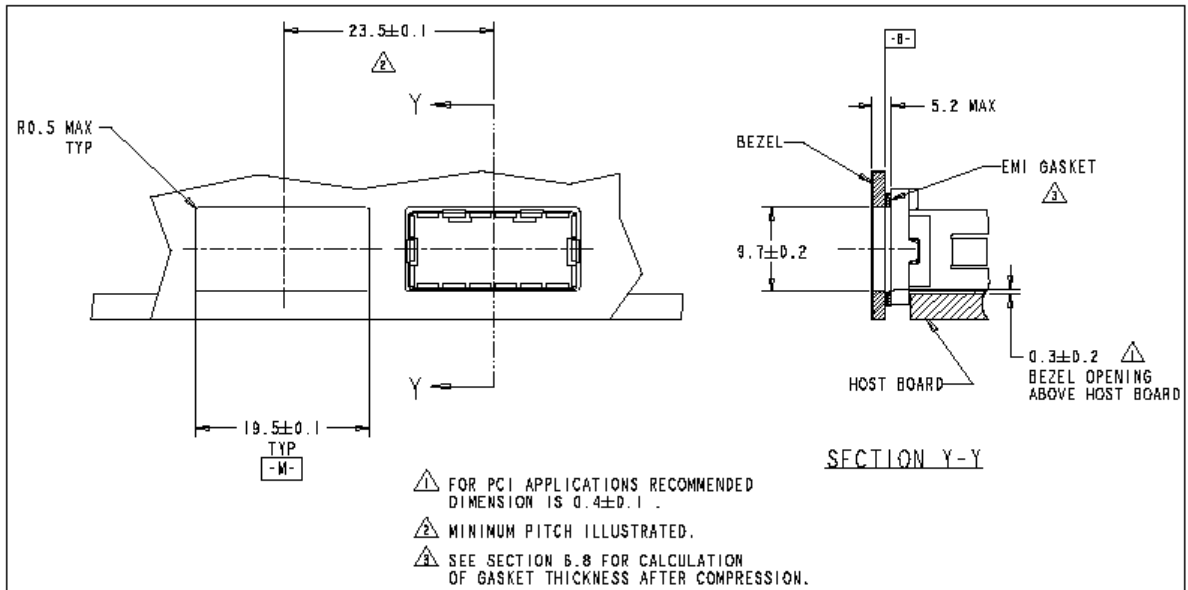

XFP Recommended Bezel Design (dimensions are in mm)

XI. References

1. 10 Gigabit Small Form Factor Pluggable Module (XFP) Multi-Source Agreement (MSA), Rev 4.5 – August 2005. Documentation is currently available at <http://www.xfpmsa.org/>
2. Application Note AN-2035: “Digital Diagnostic Monitoring Interface for XFP Optical Transceivers” – Finisar Corporation, December 2003
3. Directive 2002/95/EC of the European Council Parliament and of the Council, “on the restriction of the use of certain hazardous substances in electrical and electronic equipment”. January 27, 2003.
4. “Application Note AN-2038: Finisar Implementation Of RoHS Compliant Transceivers”, Finisar Corporation, January 21, 2005.

XII. Revision History

Revision	Date	Description
A1	5/26/2010	<ul style="list-style-type: none">• Document created.
B1	1/11/2011	<ul style="list-style-type: none">• Removed Preliminary from datasheet

XIII. For More Information

Finisar Corporation
1389 Moffett Park Drive
Sunnyvale, CA 94089-1133
Tel. 1-408-548-1000
Fax 1-408-541-6138
sales@finisar.com
www.finisar.com