

Product Specification

+3200 ps/nm (~200km) DWDM XFP Optical Transceiver

FTLX4213x3xxxx

PRODUCT FEATURES

- Supports 10.7Gb/s to 11.35Gb/s
- -500 to +3200 ps/nm Dispersion Tolerance (~200km reach without dispersion compensation)
- Supports ITU C & L-Band DWDM channels
- Supports 8x50GHz tuning range
- Temperature-stabilized DWDM CML™ transmitter
- Temperature range: 0°C to 70°C
- RoHS-6 Compliant (lead-free)
- Power dissipation <4.0W
- Adjustable receiver threshold



APPLICATIONS

- Amplified DWDM 10Gb/s SONET/SDH w/FEC
- Amplified DWDM 10Gb/s Ethernet and 10Gb/s Fibre Channel w/FEC

Finisar's FTLX4213x3xxxx Small Form Factor 10Gb/s (XFP) transceiver complies with the XFP Multi-Source Agreement (MSA) Specification¹. It supports amplified DWDM 10Gb/s SONET/SDH +FEC, 10 Gigabit Ethernet +FEC, and 10 Gigabit Fibre Channel +FEC applications over ~200km of fiber without dispersion compensation. The standard product supports narrow tunability on the C- and L-Band channels with 50GHz spacing. Digital diagnostics functions are available via a 2-wire serial interface, as specified in the XFP MSA. The transceiver is RoHS compliant and lead free per Directive 2002/95/EC³, and Finisar Application Note AN-2038⁴.

PRODUCT SELECTION

FTLX4213x3xxxx

x: tuning range

xxxx: ITU-T Channel#
(see next page)

C-Band, 8x50GHz XFPs (FTLX4213C3Cxxx)

ITU Channel #	Finisar Part Number	Start Frequency (THz)	End Frequency (THz)	Start Wavelength (nm)	End Wavelength (nm)
9155 - 9190	FTLX4213C3C155	191.55	191.90	1562.233	1565.087
9195 - 9230	FTLX4213C3C195	191.95	192.30	1558.983	1561.826
9215 - 9250	FTLX4213C3C205	192.05	192.40	1558.170	1561.010
9235 - 9270	FTLX4213C3C235	192.35	192.70	1555.747	1558.578
9255 - 9290	FTLX4213C3C255	192.55	192.90	1554.134	1556.959
9275 - 9310	FTLX4213C3C275	192.75	193.10	1552.524	1555.343
9295 - 9330	FTLX4213C3C305	193.05	193.40	1550.116	1552.926
9315 - 9350	FTLX4213C3C315	193.15	193.50	1549.315	1552.122
9355 - 9390	FTLX4213C3C355	193.55	193.90	1546.119	1548.915
9395 - 9430	FTLX4213C3C395	193.95	194.30	1542.936	1545.720
9435 - 9470	FTLX4213C3C435	194.35	194.70	1539.766	1542.539
9475 - 9510	FTLX4213C3C475	194.75	195.10	1536.609	1539.371
9515 - 9550	FTLX4213C3C515	195.15	195.50	1533.465	1536.216
9555 - 9590	FTLX4213C3C555	195.55	195.90	1530.334	1533.073

L-Band, 2x200GHz XFPs (FTLX4213J3Lxxx)

ITU Channel #	Finisar Part Number	Channel 1 Frequency (THz)	Channel 2 Frequency (THz)	Channel 1 Wavelength (nm)	Channel 2 Wavelength (nm)
8670 & 8690	FTLX4213J3L670	186.70	186.90	1605.744	1604.026
8700 & 8720	FTLX4213J3L700	187.00	187.20	1603.170	1601.460
8710 & 8730	FTLX4213J3L710	187.10	187.30	1602.311	1600.600
8780 & 8800	FTLX4213J3L780	187.80	188.00	1596.340	1594.640
8790 & 8810	FTLX4213J3L790	187.90	188.10	1595.489	1593.793
8830 & 8850	FTLX4213J3L830	188.30	188.50	1592.100	1590.411
8880 & 8900	FTLX4213J3L880	188.80	189.00	1587.880	1586.200
8910 & 8930	FTLX4213J3L910	189.10	189.30	1585.365	1583.690
8920 & 8940	FTLX4213J3L920	189.20	189.40	1584.530	1582.850
8950 & 8970	FTLX4213J3L950	189.50	189.70	1582.018	1580.350
8990 & 9010	FTLX4213J3L990	189.90	190.10	1578.690	1577.030
9030 & 9050	FTLX4213J3L030	190.30	190.50	1575.368	1573.714
9070 & 9090	FTLX4213J3L070	190.70	190.90	1572.063	1570.416

Note* → Please contact your Finisar representative for any requirements not supported by the above channel plan.

I. Pin Descriptions

Pin	Logic	Symbol	Name/Description	Ref.
1		GND	Module Ground	1
2		VEE5	Optional –5.2 Power Supply – Not required	
3	LVTTL-I	Mod-Desel	Module De-select; When held low allows the module to respond to 2-wire serial interface commands	
4	LVTTL-O	Interrupt	Interrupt (bar); Indicates presence of an important condition which can be read over the serial 2-wire interface	2
5	LVTTL-I	TX_DIS	Transmitter Disable; Transmitter laser source turned off	
6		VCC5	+5 Power Supply	
7		GND	Module Ground	1
8		VCC3	+3.3V Power Supply	
9		VCC3	+3.3V Power Supply	
10	LVTTL-I	SCL	Serial 2-wire interface clock	2
11	LVTTL-I/O	SDA	Serial 2-wire interface data line	2
12	LVTTL-O	Mod_Abs	Module Absent; Indicates module is not present. Grounded in the module.	2
13	LVTTL-O	Mod_NR	Module Not Ready; Finisar defines it as a logical OR between RX_LOS and Loss of Lock in TX/RX.	2
14	LVTTL-O	RX_LOS	Receiver Loss of Signal indicator	2
15		GND	Module Ground	1
16		GND	Module Ground	1
17	CML-O	RD-	Receiver inverted data output	
18	CML-O	RD+	Receiver non-inverted data output	
19		GND	Module Ground	1
20		VCC2	+1.8V Power Supply – Not required	
21	LVTTL-I	P_Down/RST	Power Down; When high, places the module in the low power stand-by mode and on the falling edge of P_Down initiates a module reset Reset; The falling edge initiates a complete reset of the module including the 2-wire serial interface, equivalent to a power cycle.	
22		VCC2	+1.8V Power Supply – Not required	
23		GND	Module Ground	1
24	PECL-I	RefCLK+	Reference Clock non-inverted input, AC coupled on the host board – Not required	
25	PECL-I	RefCLK-	Reference Clock inverted input, AC coupled on the host board – Not required	
26		GND	Module Ground	1
27		GND	Module Ground	1
28	CML-I	TD-	Transmitter inverted data input	
29	CML-I	TD+	Transmitter non-inverted data input	
30		GND	Module Ground	1

Notes:

1. Module circuit ground is isolated from module chassis ground within the module.
2. Open collector; should be pulled up with 4.7k – 10kohms on host board to a voltage between 3.15V and 3.6V.

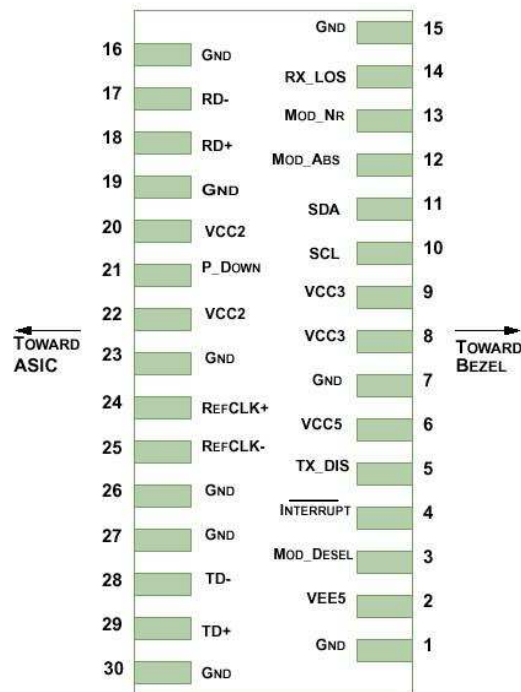

Diagram of Host Board Connector Block Pin Numbers and Names

II. Absolute Maximum Ratings

Parameter	Symbol	Min	Typ	Max	Unit	Ref.
Maximum Supply Voltage #1	V _{cc3}	-0.5		4.0	V	
Maximum Supply Voltage #2	V _{cc5}	-0.5		6.0	V	
Storage Temperature	T _S	-40		85	°C	
Case Operating Temperature	T _{OP}	0		70	°C	
Receiver Damage Threshold	P _{Rdmg}	+5			dBm	

III. Electrical Characteristics ($T_{OP} = 0$ to 70 °C, $V_{CC5} = 4.75$ to 5.25 Volts)

Parameter	Symbol	Min	Typ	Max	Unit	Ref.	
Supply Voltage #1	Vcc5	4.75		5.25	V		
Supply Voltage #2	Vcc3	3.13		3.46	V		
Supply Current – Vcc5 supply	Icc5			500	mA		
Supply Current – Vcc3 supply	Icc3			750	mA		
Module total power	P			4.0	W	1	
Transmitter							
Input differential impedance	R_{in}		100		Ω	2	
Differential data input swing	$V_{in,pp}$	120		820	mV		
Transmit Disable Voltage	V_D	2.0		Vcc	V	3	
Transmit Enable Voltage	V_{EN}	GND		GND+ 0.8	V		
Transmit Disable Assert Time				10	us		
Receiver							
Differential data output swing	$V_{out,pp}$	340	650	850	mV	4	
Data output rise time	t_r			38	ps	5	
Data output fall time	t_f			38	ps	5	
LOS Fault	$V_{LOS\ fault}$	Vcc – 0.5		$V_{CC_{HOST}}$	V	6	
LOS Normal	$V_{LOS\ norm}$	GND		GND+0.5	V	6	
Power Supply Rejection	PSR	See Note 7 below					7

Notes:

1. Maximum total power value is specified across the full temperature and voltage range.
2. After internal AC coupling.
3. Or open circuit.
4. Into 100 ohms differential termination.
5. 20 – 80 %
6. Loss Of Signal is open collector to be pulled up with a 4.7k – 10kohm resistor to 3.15 – 3.6V. Logic 0 indicates normal operation; logic 1 indicates no signal detected.
7. Per Section 2.7.1. in the XFP MSA Specification¹.

IV. Optical Characteristics (EOL, T_{OP} = 0 to 70°C, V_{CC5} = 4.75 to 5.25 Volts)

Transmitter						
Parameter	Symbol	Min	Typ	Max	Unit	Ref.
Output Opt. Pwr: 9/125 SMF	P _{OUT}	0		+4.0	dBm	
Optical Extinction Ratio	ER	8.2			dB	1
Center Wavelength Spacing			50		GHz	2
Transmitter Center Wavelength – End Of Life	fc	X-5	X	X+5	GHz	3
Sidemode Suppression ratio	SSR _{min}	35			dB	
Tx Jitter 20kHz-80MHz	T _{Xj1}			0.3	UI	4,5
Tx Jitter 4MHz – 80MHz	T _{Xj2}			0.1	UI	4,5
Tx Disable Negate Time	t _{TxE}			60	seconds	
Relative Intensity Noise	RIN			-135	dB/Hz	
Receiver						
Maximum Input Power	P _{MAX}	-7			dBm	
Optical Center Wavelength	λ _C	1270		1615	nm	
Receiver Reflectance	R _{RX}			-27	dB	
LOS De-Assert	LOS _D			-30	dBm	
LOS Assert	LOS _A	-37			dBm	
LOS Hysteresis		0.5			dB	
Receiver Sensitivity						6
Data rate (Gb/s)	BER	Dispersion (ps/nm)	Sensitivity back-to-back at OSNR>30dB (dBm)	Sensitivity at -500 to +3200ps/nm with OSNR>30dB (dB)	Threshold Adjustm.	
10.7	1e-4	-500 to +3200	-27	-25	Yes	
11.1	1e-4	-500 to +3200	-27	-25	Yes	
11.3	1e-4	-500 to +3200	-27	-25	Yes	
OSNR Performance						6,7
Data rate (Gb/s)	BER	Dispersion (ps/nm)	Max OSNR, -500 ps/nm to +3200 ps/nm at Power: -8 to -19dBm (dB)			Threshold Adjust.
10.7	1e-4	-500 to +3200	19			Yes
11.1	1e-4	-500 to +3200	19			Yes
11.3	1e-4	-500 to +3200	19			Yes

Notes:

1. Measured with unfiltered eye pattern. (without 4th order Bessel-Thompson Filter)
2. Corresponds to approximately 0.8 nm. Please contact Finisar for 50GHz support.
3. X = Specified ITU Grid frequency. Wavelength stability is achieved within xx seconds of power up. Please contact Finisar for narrow tunability support.
4. Measured with a host jitter of 50 mUI peak-to-peak.
5. GR-253-CORE Issue 4
6. Measured at 1528-1600nm with worst ER; BER<10⁻¹²; PRBS31.
7. All OSNR measurements are performed with 0.1nm resolution.

V. General Specifications

Parameter	Symbol	Min	Typ	Max	Units	Ref.
Bit Rate	BR	10.7		11.3	Gb/s	
Maximum Supported Link Length	L _{MAX}		200		km	1

Notes:

- Distance indicates dispersion budget. Optical amplification is required to achieve maximum distance.

VI. Environmental Specifications

Finisar FTLX4213x3xxxx XFP transceivers have an operating temperature range from -5°C to +70°C case temperature.

Parameter	Symbol	Min	Typ	Max	Units	Ref.
Case Operating Temperature	T _{op}	0		70	°C	
Storage Temperature	T _{sto}	-40		85	°C	

VII. Regulatory Compliance

Finisar FTLX4213x3xxxx XFP transceivers are Class 1 Laser Products. They are certified per the following standards:

Feature	Agency	Standard	Certificate Number
Laser Eye Safety	FDA/CDRH	CDRH 21 CFR 1040 and Laser Notice 50	9210176-77
Laser Eye Safety	TÜV	EN 60825-1: 2007, EN60825-2:2004+A1 IEC 60825-1: 2007 (2 nd Edition) IEC 60825-2: 2010 (3 rd Edition)	72101686
Electrical Safety	TÜV	EN 60950:2006+A11	72101686
Electrical Safety	UL/CSA	CLASS 3862.07 CLASS 3862.87	2283290

Copies of the referenced certificates are available at Finisar Corporation upon request.

VIII. Digital Diagnostics Functions

As defined by the XFP MSA¹, Finisar XFP transceivers provide digital diagnostic functions via a 2-wire serial interface, which allows real-time access to the following operating parameters:

- Transceiver temperature
- Laser bias current
- Transmitted optical power
- Received optical power
- Transceiver supply voltage
- TEC Temperature

It also provides a sophisticated system of alarm and warning flags, which may be used to alert end-users when particular operating parameters are outside of a factory-set normal range.

The operating and diagnostics information is monitored and reported by a Digital Diagnostics Transceiver Controller (DDTC) inside the transceiver, which is accessed through the 2-wire serial interface. When the serial protocol is activated, the serial clock signal (SCL pin) is generated by the host. The positive edge clocks data into the XFP transceiver into those segments of its memory map that are not write-protected. The negative edge clocks data from the XFP transceiver. The serial data signal (SDA pin) is bi-directional for serial data transfer. The host uses SDA in conjunction with SCL to mark the start and end of serial protocol activation. The memories are organized as a series of 8-bit data words that can be addressed individually or sequentially. The 2-wire serial interface provides sequential or random access to the 8 bit parameters, addressed from 000h to the maximum address of the memory.

For more detailed information, including memory map definitions, please see the XFP MSA documentation¹.

Receiver Threshold Adjustment

The FTLX4213M3xxx also provides access to receiver decision threshold adjustment via 2-wire serial interface, in order to improve receiver OSNR performance based on specific link conditions. It is implemented as follows:

- Rx Threshold of XFP transceivers will be factory-set for optimized performance in non-FEC applications. This will be the default value during both cold start (power-up) and warm start (module reset).
- The transceiver supports adjustment of Rx Threshold value by the host through register 76d, table 01h. This is intended to be used in FEC applications.

- Register 76d, table 01h is a volatile memory. Therefore if the transceiver is power-cycled, the register starts up with a value of 00h which corresponds to the default Rx Threshold value.
- The threshold adjustment input value is 2's complement 7 bit value (-128 to +127), with 0 corresponding to default Rx threshold value. Full range of adjustment provides at least a $\pm 10\%$ change in Rx threshold from the default value.

ITU channel Tuning (per SFF-8477 rev 1.3)

To avoid possible conflict with legacy tuning systems designed to INF-8077i, the frequency grid tuning commands of SFF-8477 supplement rather than supplant the wavelength grid tuning commands of INF-8077i.

Tuning Management Interface for ITU Frequency Grid Applications

Finisar's FTLX4213M3xxxx supports Frequency tuning by channel number only. The XFP frequency tuning is indicated by the transceiver description encoded in Serial ID Byte 138 bit 3.

Data Address	Bit	Description
138	3	Tunable DWDM (selection by channel number, bytes 112-113)
138	2	Tunable DWDM (selection in 50 pm steps, bytes 72-73)
138	0-1	Reserved

A desired frequency channel can be commanded by the user by writing into Bytes 112 (MSB) and 113 (LSB).

Frequency channel control command:

Address	Bit	Name	Description
112 (MSB) & 113 (LSB)	All	Channel Number Set	User input of channel number, which is an integer 1 to N (N=Number of Channels)
114 (MSB) & 115 (LSB)	All	Frequency Error	Frequency error reported in 16 bit signed integer with LSB=0.1 GHz
116 - 117	All	Reserved	Reserved

The channel number is derived from the following equation using parameters found in Module capabilities as listed in Byte Addresses 60-69:

$$\text{Channel number} = 1 + (\text{Desired Frequency} - \text{First Frequency}) / \text{Grid Spacing}$$

If "0" is used for the channel number, the XFP will go into standby mode until a valid channel number is received.

Tunable Transceiver Initialization / Power Cycling:

When a tunable module is plugged in for the first time it will go to a default channel, or if Tx_DIS is asserted it will go to a standby condition.

When the module is power cycled it will automatically go to the last channel selected, or if Tx_DIS is asserted it will go to a standby condition. If Tx_DIS is asserted, the last channel selected will be cleared, and a valid new channel command will be required to set a channel.

If the Tx is disabled and then re-enabled, the module returns to the last channel selected.

IX. Mechanical Specifications

Finisar's XFP transceivers are compliant with the dimensions defined by the XFP Multi-Sourcing Agreement (MSA).

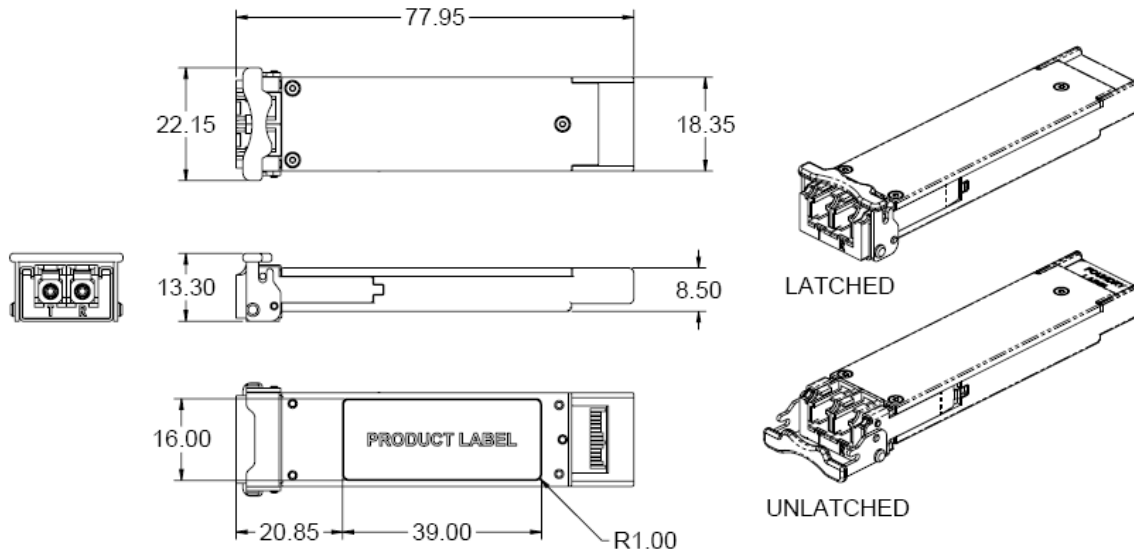

XFP Transceiver (dimensions are in mm)

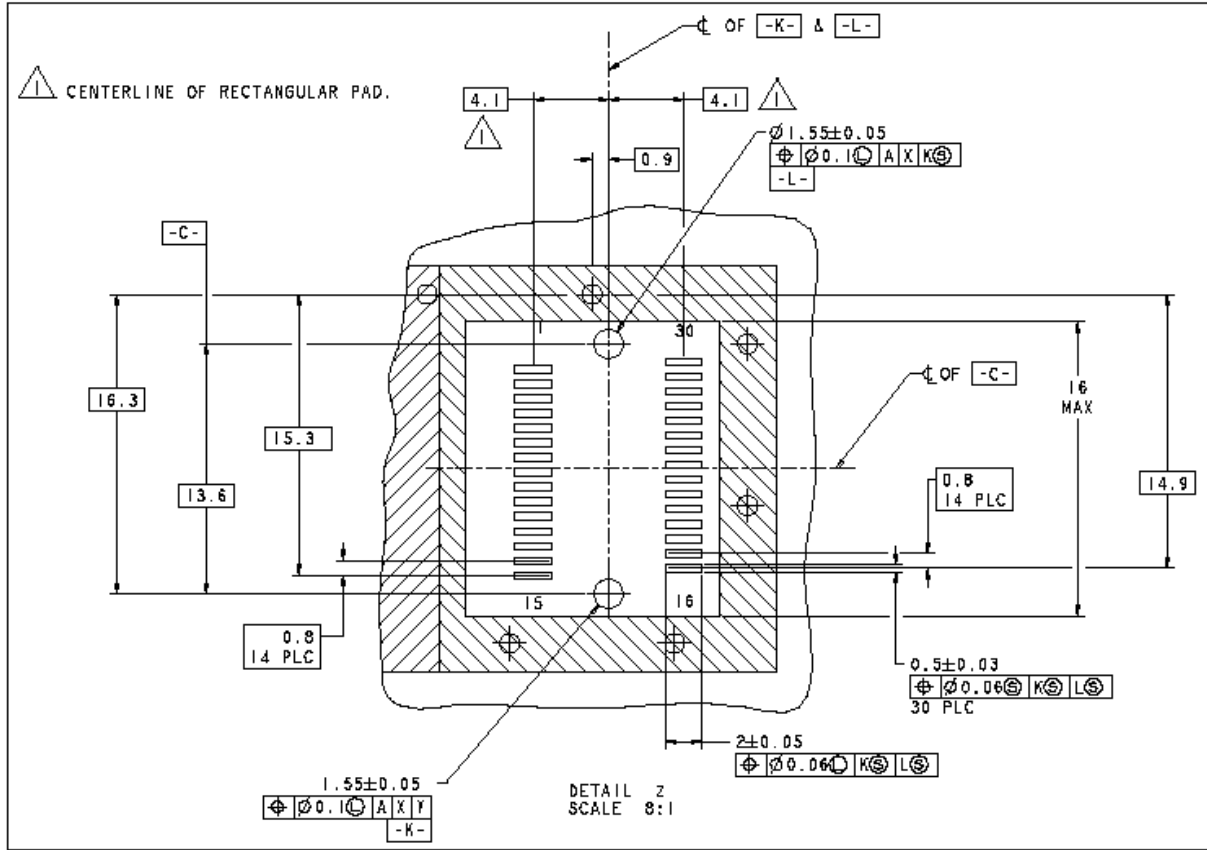

XFP Detail Host Board Mechanical Layout (dimensions are in mm)

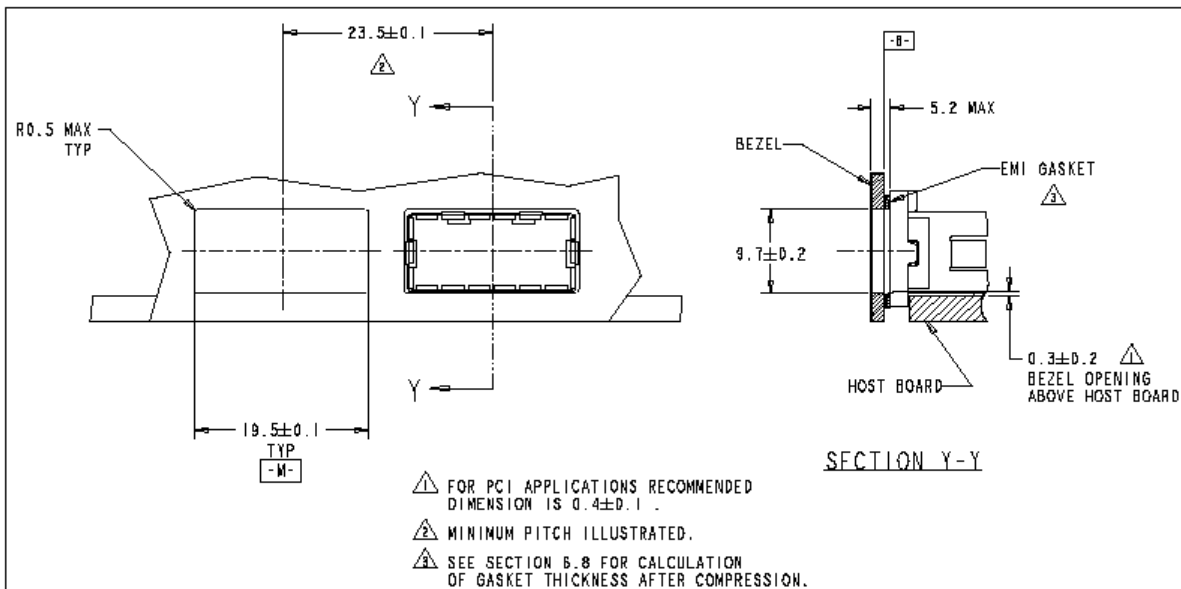

XFP Recommended Bezel Design (dimensions are in mm)

XI. Notes & Exceptions

The FTLX4213x3xxxx product family has the following exceptions to the XFP MSA;

- Tx_Disable time of <100usec,
- Tx_Disable negate time of <60seconds
- Tx_NR is not implemented.
- Reset Completion Bit is not implemented in EEPROM (Table 0: Byte 84: Bit 0)

XII. References

1. 10 Gigabit Small Form Factor Pluggable Module (XFP) Multi-Source Agreement (MSA), Rev 4.5 – August 2005. Documentation is currently available at <http://www.xfpmsa.org/>
2. Application Note AN-2035: “Digital Diagnostic Monitoring Interface for XFP Optical Transceivers” – Finisar Corporation, December 2003
3. Directive 2002/95/EC of the European Council Parliament and of the Council, “on the restriction of the use of certain hazardous substances in electrical and electronic equipment”. January 27, 2003.
4. “Application Note AN-2038: Finisar Implementation Of RoHS Compliant Transceivers”, Finisar Corporation, January 21, 2005.

XIII. Revision History

Revision	Date	Description
A1	4/15/2008	<ul style="list-style-type: none"> • Preliminary document created.
C1	7/20/2009	<ul style="list-style-type: none"> • Updated Optical Spec for OSNR & Rx_Sensitivity • Updated Tx_Disable <100us
C2	3/18/2010	<ul style="list-style-type: none"> • Updated Icc3 value • Corrected Finisar Part Numbers
C3	8/28/2010	<ul style="list-style-type: none"> • Added “Notes & Exceptions” Section
C4	12/16/2010	<ul style="list-style-type: none"> • Updated channel availability

XII. For More Information

Finisar Corporation
 1389 Moffett Park Drive
 Sunnyvale, CA 94089-1133
 Tel. 1-408-548-1000
 Fax 1-408-541-6138
sales@finisar.com
www.finisar.com