



# STFW4N150 STP4N150, STW4N150

N-channel 1500 V, 5  $\Omega$ , 4 A, PowerMESH™ Power MOSFET  
in TO-220, TO-247, TO-3PF

## Features

Type	V <sub>DSS</sub>	R <sub>DS(on)</sub> max	I <sub>D</sub>	P <sub>w</sub>
STFW4N150	1500 V	< 7 $\Omega$	4 A	63 W
STP4N150	1500 V	< 7 $\Omega$	4 A	160 W
STW4N150	1500 V	< 7 $\Omega$	4 A	160 W

- 100% avalanche tested
- Intrinsic capacitances and Q<sub>g</sub> minimized
- High speed switching
- Fully isolated TO-3PF plastic packages
- Creepage distance path is 5.4 mm (typ.) for TO-3PF

## Application

- Switching applications

## Description

Using the well consolidated high voltage MESH OVERLAY™ process, STMicroelectronics has designed an advanced family of very high voltage Power MOSFETs with outstanding performances. The strengthened layout coupled with the company's proprietary edge termination structure, gives the lowest R<sub>DS(on)</sub> per area, unrivalled gate charge and switching characteristics.

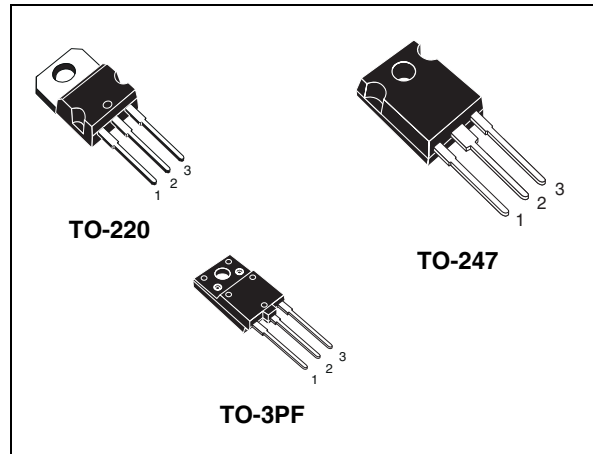

Figure 1. Internal schematic diagram.

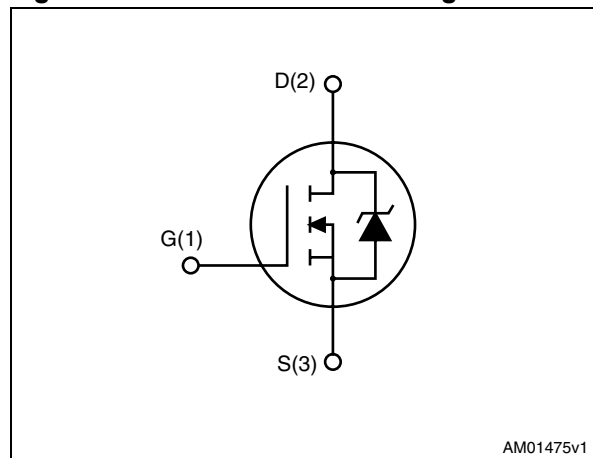

Table 1. Device summary

Order codes	Marking	Package	Packaging
STFW4N150	4N150	TO-3PF	Tube
STP4N150	P4N150	TO-220	Tube
STW4N150	W4N150	TO-247	Tube

# Contents

<b>1</b>	<b>Electrical ratings</b> .....	<b>3</b>
<b>2</b>	<b>Electrical characteristics</b> .....	<b>4</b>
	2.1 Electrical characteristics (curves) .....	6
<b>3</b>	<b>Test circuits</b> .....	<b>9</b>
<b>4</b>	<b>Package mechanical data</b> .....	<b>10</b>
<b>5</b>	<b>Revision history</b> .....	<b>14</b>

# 1 Electrical ratings

**Table 2. Absolute maximum ratings**

Symbol	Parameter	Value			Unit
		TO-220	TO-247	TO-3PF	
$V_{DS}$	Drain-source voltage ( $V_{GS} = 0$ )	1500			V
$V_{GS}$	Gate- source voltage	$\pm 30$			V
$I_D$	Drain current (continuous) at $T_C = 25\text{ }^\circ\text{C}$	4	4	4 <sup>(1)</sup>	A
$I_D$	Drain current (continuous) at $T_C = 100\text{ }^\circ\text{C}$	2.5	2.5	2.5 <sup>(1)</sup>	A
$I_{DM}^{(1)}$	Drain current (pulsed)	12	12	12 <sup>(1)</sup>	A
$P_{TOT}$	Total dissipation at $T_C = 25\text{ }^\circ\text{C}$	160		63	W
$V_{ISO}$	Insulation withstand voltage (RMS) from all three leads to external heat sink ( $t=1\text{ s}; T_C=25\text{ }^\circ\text{C}$ )			3500	V
$T_{stg}$	Storage temperature	-55 to 150			$^\circ\text{C}$
$T_j$	Max. operating junction temperature	150			$^\circ\text{C}$

1. Pulse width limited by safe operating area

**Table 3. Thermal data**

Symbol	Parameter	Value			Unit
		TO-220	TO-247	TO-3PF	
$R_{thj-case}$	Thermal resistance junction-case max	0.78		2	$^\circ\text{C}/\text{W}$
$R_{thj-amb}$	Thermal resistance junction-ambient max	62.5	50		$^\circ\text{C}/\text{W}$

**Table 4. Avalanche characteristics**

Symbol	Parameter	Value	Unit
$I_{AR}$	Avalanche current, repetitive or not-repetitive (pulse width limited by $T_j$ max)	4	A
$E_{AS}$	Single pulse avalanche energy (starting $T_j = 25\text{ }^\circ\text{C}$ , $I_D = I_{AR}$ , $V_{DD} = 50\text{ V}$ )	350	mJ

## 2 Electrical characteristics

( $T_{CASE} = 25\text{ °C}$  unless otherwise specified)

**Table 5. On/off states**

Symbol	Parameter	Test conditions	Min.	Typ.	Max.	Unit
$V_{(BR)DSS}$	Drain-source Breakdown voltage	$I_D = 1\text{ mA}$ , $V_{GS} = 0$	1500			V
$I_{DSS}$	Zero gate voltage Drain current ( $V_{GS} = 0$ )	$V_{DS} = \text{Max rating}$ $V_{DS} = \text{Max rating}$ , $T_C = 125\text{ °C}$			10 500	$\mu\text{A}$ $\mu\text{A}$
$I_{GSS}$	Gate-body leakage current ( $V_{DS} = 0$ )	$V_{GS} = \pm 30\text{ V}$			$\pm 100$	nA
$V_{GS(th)}$	Gate threshold voltage	$V_{DS} = V_{GS}$ , $I_D = 250\text{ }\mu\text{A}$	3	4	5	V
$R_{DS(on)}$	Static drain-source on resistance	$V_{GS} = 10\text{ V}$ , $I_D = 2\text{ A}$		5	7	$\Omega$

**Table 6. Dynamic**

Symbol	Parameter	Test conditions	Min.	Typ.	Max.	Unit
$g_{fs}^{(1)}$	Forward transconductance	$V_{DS} = 30\text{ V}$ , $I_D = 2\text{ A}$	-	3.5		S
$C_{iss}$	Input capacitance	$V_{DS} = 25\text{ V}$ , $f = 1\text{ MHz}$ , $V_{GS} = 0$	-	1300		pF
$C_{oss}$	Output capacitance			120		pF
$C_{rss}$	Reverse transfer capacitance			12		pF
$t_{d(on)}$	Turn-on delay time	$V_{DD} = 750\text{ V}$ , $I_D = 2\text{ A}$ , $R_G = 4.7\text{ }\Omega$ , $V_{GS} = 10\text{ V}$ <i>Figure 19</i>	-	35		ns
$T_r$	Rise time			30		ns
$t_{d(off)}$	Turn-off delay time			45		ns
$t_f$	Fall time			45		ns
$Q_g$	Total gate charge	$V_{DD} = 600\text{ V}$ , $I_D = 4\text{ A}$ , $V_{GS} = 10\text{ V}$ <i>Figure 20</i>	-	30	50	nC
$Q_{gs}$	Gate-source charge			10		nC
$Q_{gd}$	Gate-drain charge			9		nC

1. Pulsed: pulse duration=300  $\mu\text{s}$ , duty cycle 1.5%

Table 7. Source drain diode

Symbol	Parameter	Test conditions	Min.	Typ.	Max.	Unit
$I_{SD}$	Source-drain current		-		4	A
$I_{SDM}^{(1)}$	Source-drain current (pulsed)		-		12	A
$V_{SD}^{(2)}$	Forward on voltage	$I_{SD} = 4 \text{ A}$ , $V_{GS} = 0$	-		2	V
$t_{rr}$	Reverse recovery time	$I_{SD} = 4 \text{ A}$ , $di/dt = 100 \text{ A}/\mu\text{s}$	-	510		ns
$Q_{rr}$	Reverse recovery charge	$V_{DD} = 45 \text{ V}$	-	3		$\mu\text{C}$
$I_{RRM}$	Reverse recovery current	<a href="#">Figure 21</a>	-	12		A
$t_{rr}$	Reverse recovery time	$I_{SD} = 4 \text{ A}$ , $di/dt = 100 \text{ A}/\mu\text{s}$	-	615		ns
$Q_{rr}$	Reverse recovery charge	$V_{DD} = 45 \text{ V}$ , $T_j = 150^\circ\text{C}$	-	4		$\mu\text{C}$
$I_{RRM}$	Reverse recovery current	<a href="#">Figure 21</a>	-	12.6		A

1. Pulse width limited by safe operating area
2. Pulsed: pulse duration=300 $\mu\text{s}$ , duty cycle 1.5%

## 2.1 Electrical characteristics (curves)

Figure 2. Safe operating area for TO-220

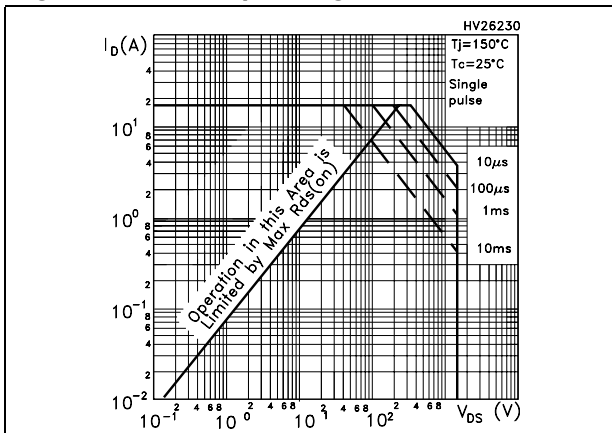

Figure 3. Thermal impedance for TO-220

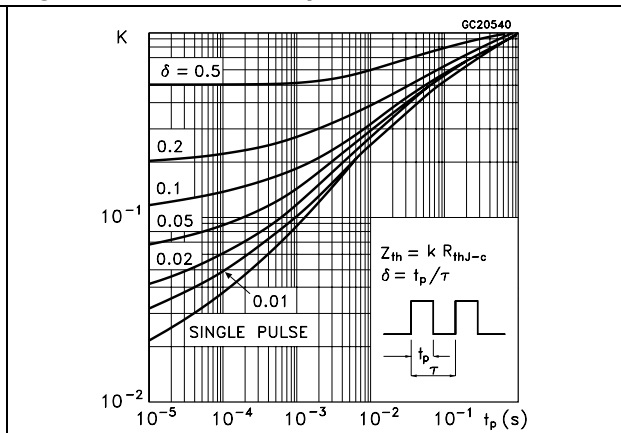

Figure 4. Safe operating area for TO-3PF

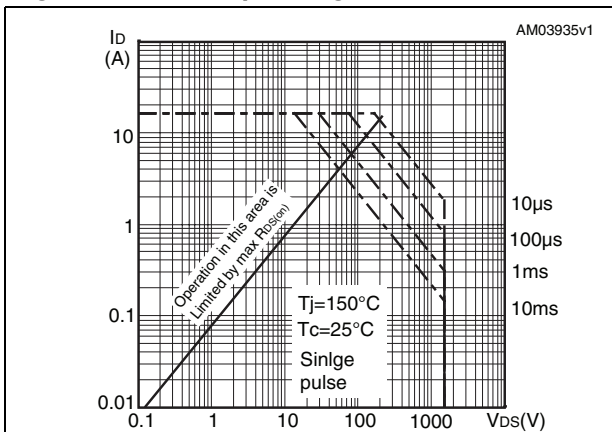

Figure 5. Thermal impedance for TO-3PF

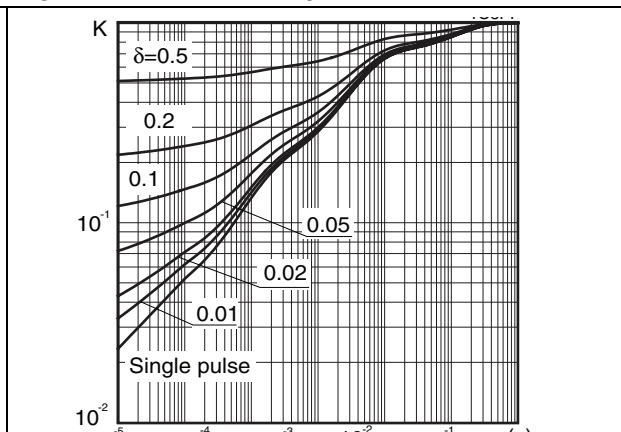

Figure 6. Safe operating area for TO-247

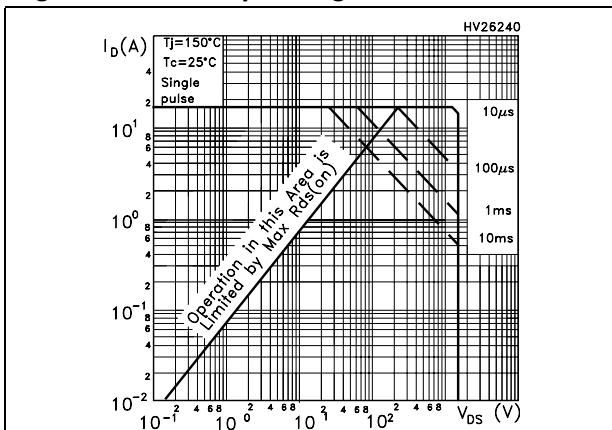

Figure 7. Thermal impedance for TO-247

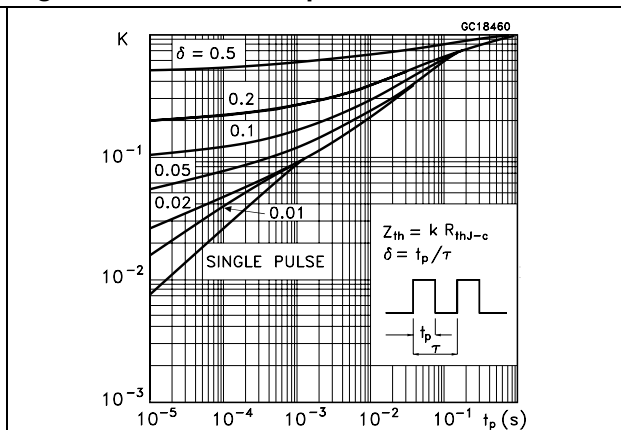

Figure 8. Output characteristics

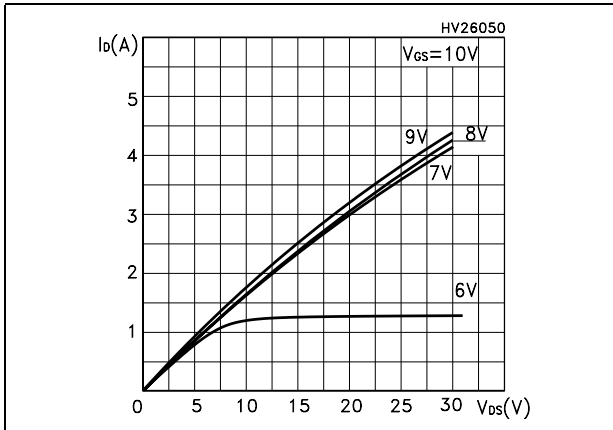

Figure 9. Transfer characteristics

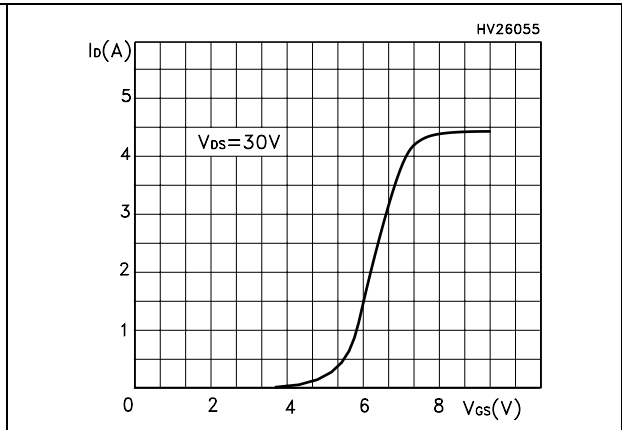

Figure 10. Transconductance

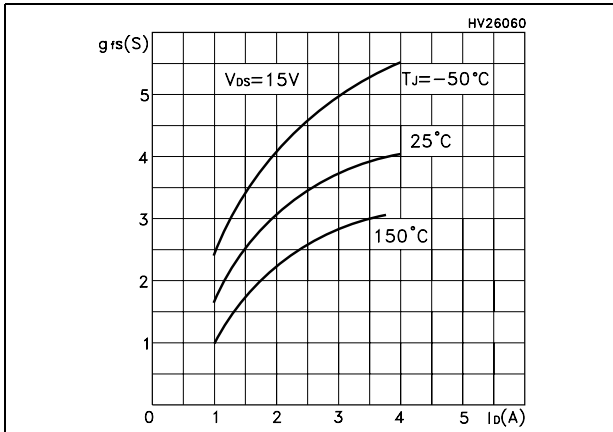

Figure 11. Static drain-source on resistance

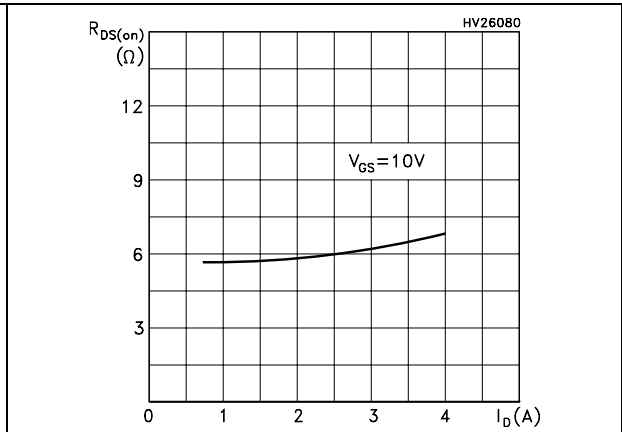

Figure 12. Gate charge vs gate-source voltage Figure 13. Capacitance variations

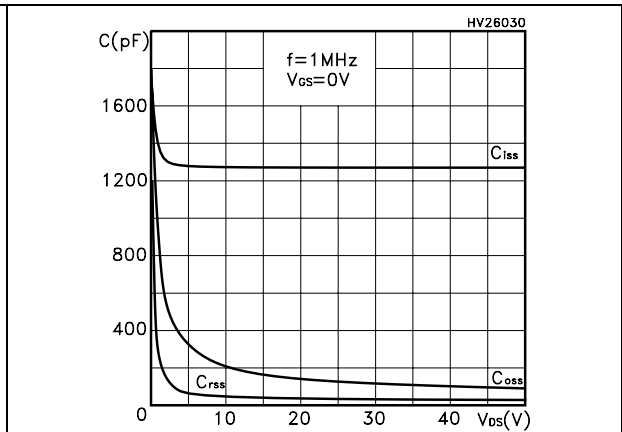
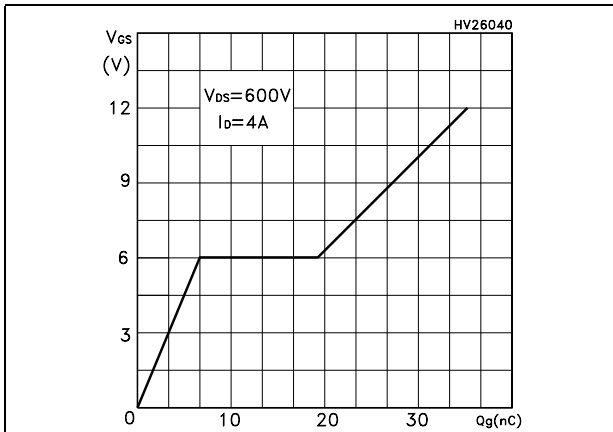

Figure 14. Normalized gate threshold voltage vs temperature

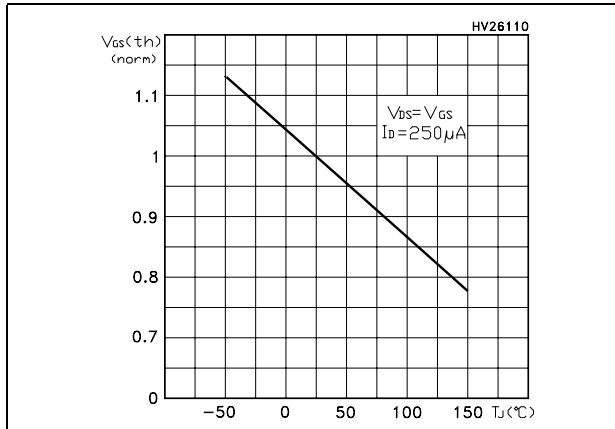

Figure 15. Normalized on resistance vs temperature

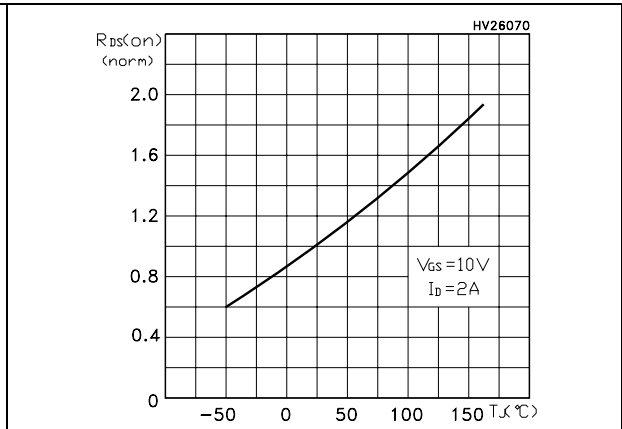

Figure 16. Source-drain diode forward characteristics

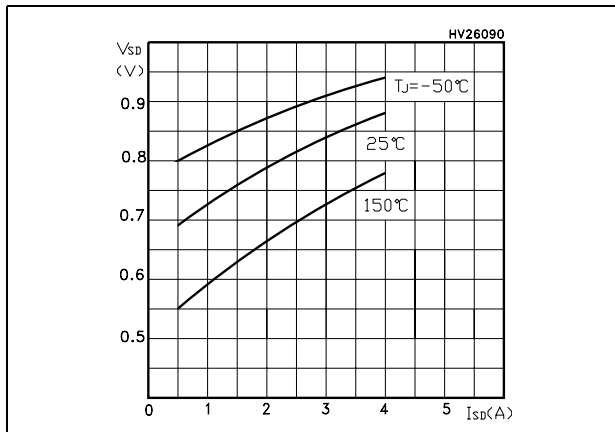

Figure 17. Normalized  $B_{VDSS}$  vs temperature

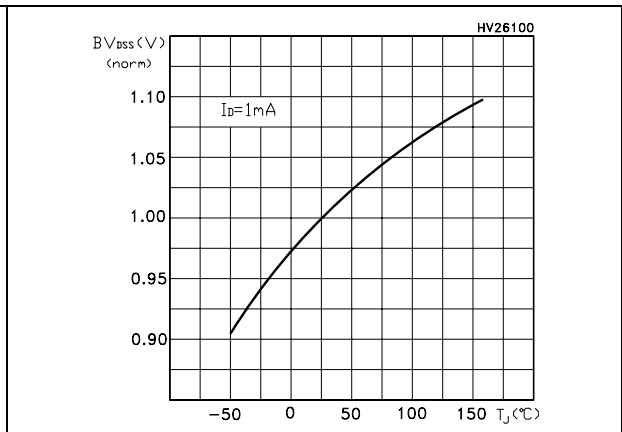
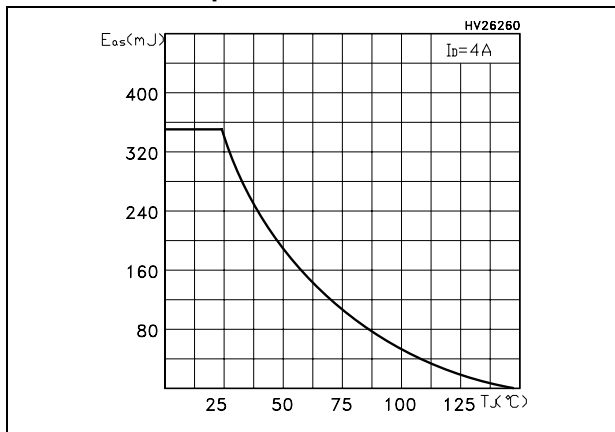

Figure 18. Maximum avalanche energy vs temperature





### 3 Test circuits

**Figure 19. Switching times test circuit for resistive load**

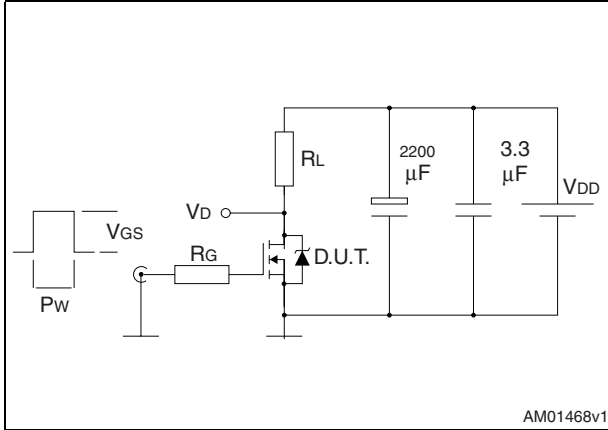

AM01468v1

**Figure 20. Gate charge test circuit**

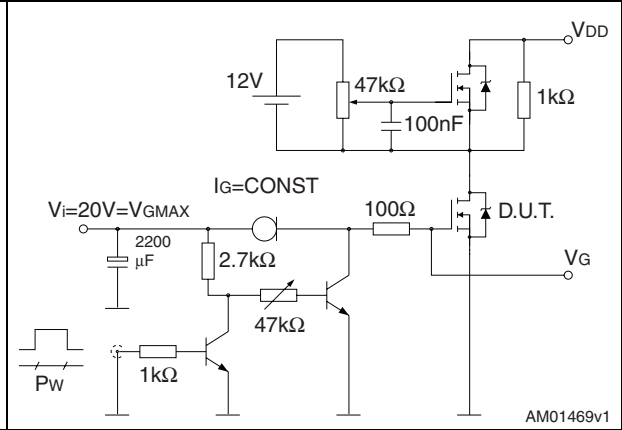

AM01469v1

**Figure 21. Test circuit for inductive load switching and diode recovery times**

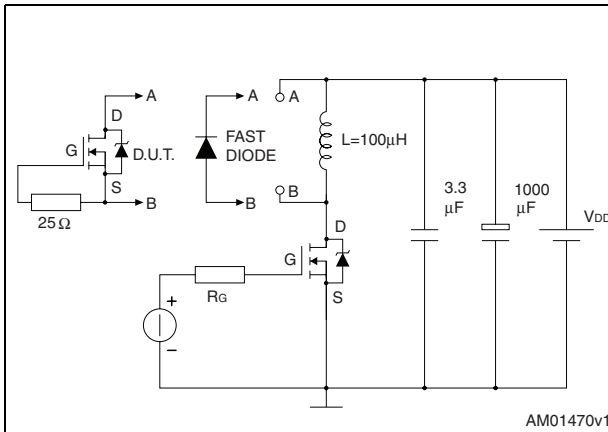

AM01470v1

**Figure 22. Unclamped inductive load test circuit**

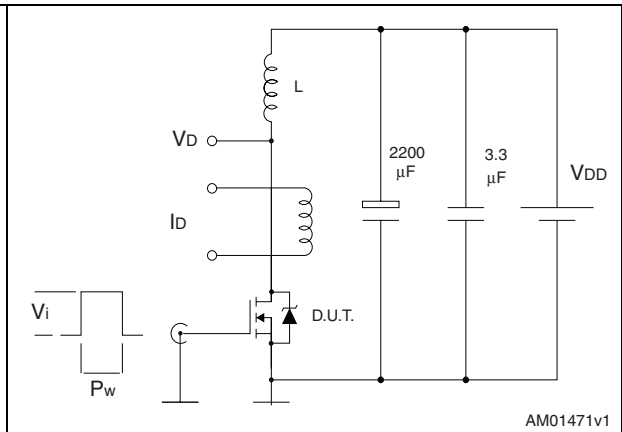

AM01471v1

**Figure 23. Unclamped inductive waveform**

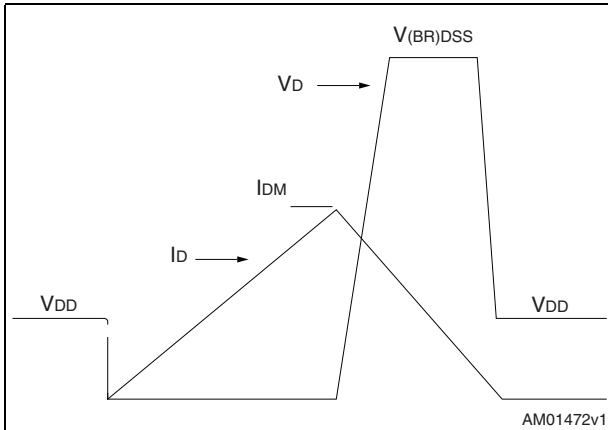

AM01472v1

**Figure 24. Switching time waveform**

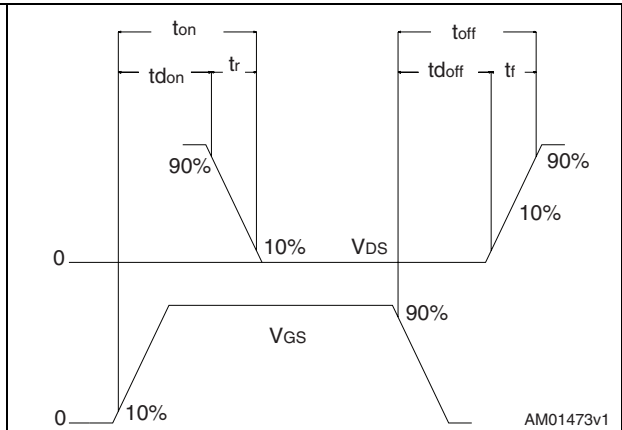

AM01473v1

## 4 Package mechanical data

In order to meet environmental requirements, ST offers these devices in different grades of ECOPACK<sup>®</sup> packages, depending on their level of environmental compliance. ECOPACK<sup>®</sup> specifications, grade definitions and product status are available at: [www.st.com](http://www.st.com). ECOPACK is an ST trademark.

TO-220 mechanical data

Dim	mm			inch		
	Min	Typ	Max	Min	Typ	Max
A	4.40		4.60	0.173		0.181
b	0.61		0.88	0.024		0.034
b1	1.14		1.70	0.044		0.066
c	0.48		0.70	0.019		0.027
D	15.25		15.75	0.6		0.62
D1		1.27			0.050	
E	10		10.40	0.393		0.409
e	2.40		2.70	0.094		0.106
e1	4.95		5.15	0.194		0.202
F	1.23		1.32	0.048		0.051
H1	6.20		6.60	0.244		0.256
J1	2.40		2.72	0.094		0.107
L	13		14	0.511		0.551
L1	3.50		3.93	0.137		0.154
L20		16.40			0.645	
L30		28.90			1.137	
∅P	3.75		3.85	0.147		0.151
Q	2.65		2.95	0.104		0.116

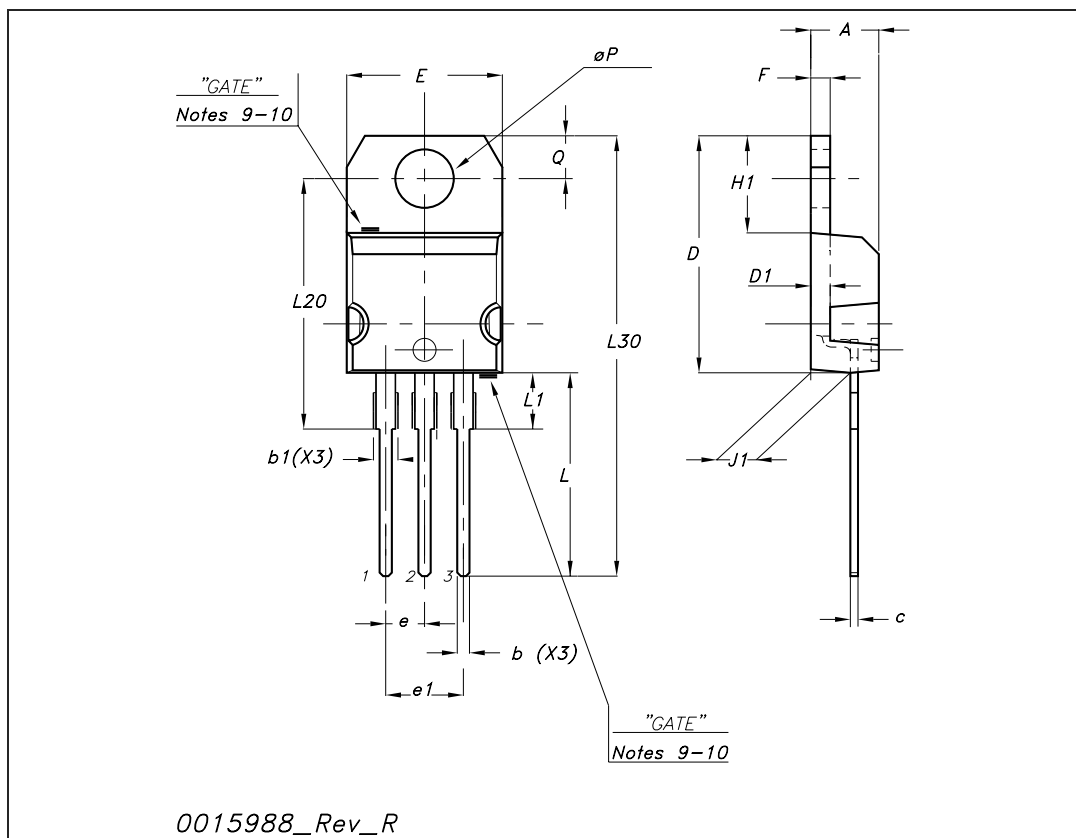

**TO-247 Mechanical data**

Dim.	mm.		
	Min.	Typ	Max.
A	4.85		5.15
A1	2.20		2.60
b	1.0		1.40
b1	2.0		2.40
b2	3.0		3.40
c	0.40		0.80
D	19.85		20.15
E	15.45		15.75
e		5.45	
L	14.20		14.80
L1	3.70		4.30
L2		18.50	
∅P	3.55		3.65
∅R	4.50		5.50
S		5.50	

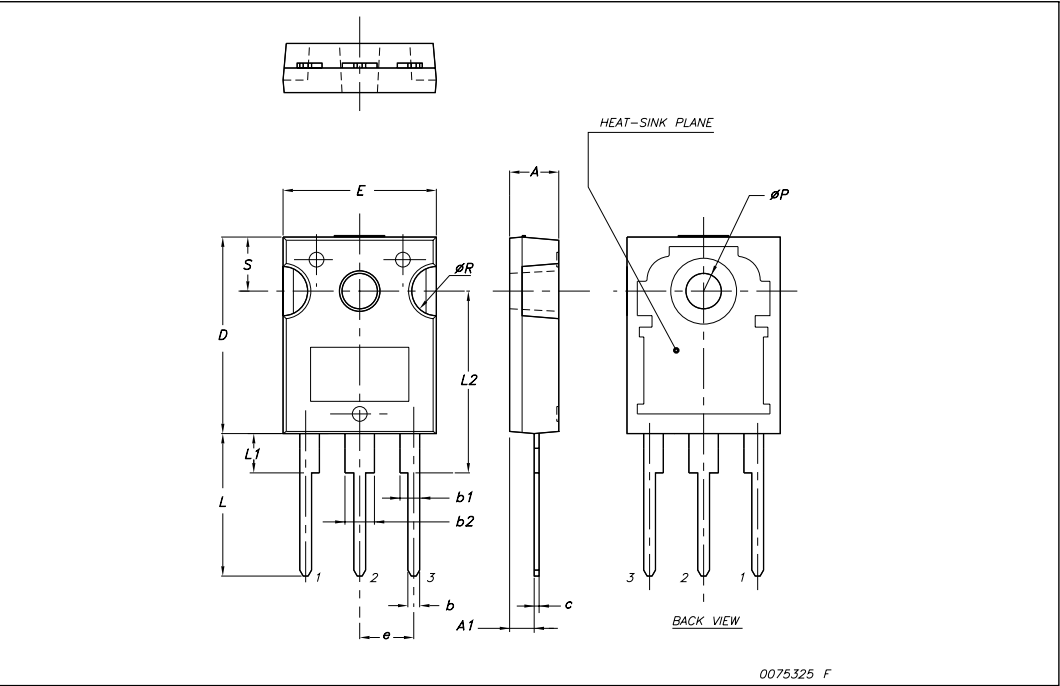

**TO-3PF mechanical data**

DIM.	mm.		
	min.	typ	max.
A	5.30		5.70
C	2.80		3.20
D	3.10		3.50
D1	1.80		2.20
E	0.80		1.10
F	0.65		0.95
F2	1.80		2.20
G	10.30		11.50
G1		5.45	
H	15.30		15.70
L	9.80	10	10.20
L2	22.80		23.20
L3	26.30		26.70
L4	43.20		44.40
L5	4.30		4.70
L6	24.30		24.70
L7	14.60		15
N	1.80		2.20
R	3.80		4.20
Dia	3.40		3.80

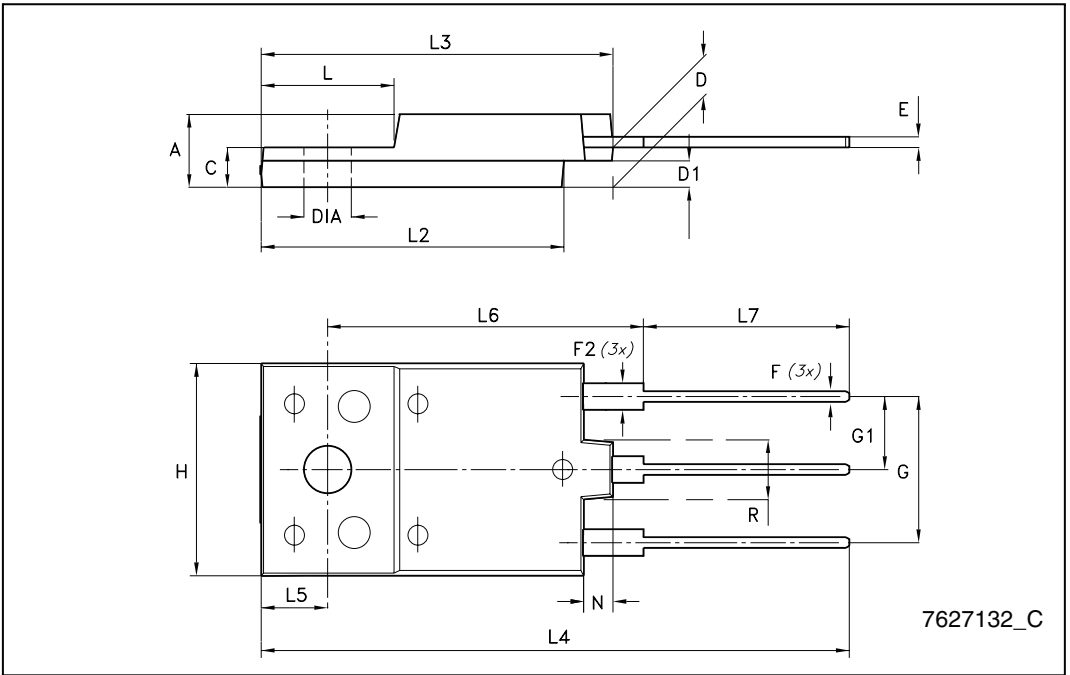

## 5 Revision history

**Table 8. Document revision history**

Date	Revision	Changes
29-Mar-2005	1	Initial release
07-Jul-2005	2	Removed TO-220FP
07-Oct-2005	3	Document status promoted from preliminary data to datasheet
10-Aug-2006	4	Document reformatted, no content change
06-Nov-2007	5	Updated unit on <a href="#">Table 5: On/off states</a>
09-Apr-2008	6	Added new packages: TO-220FH, TO-3PF
21-Jan-2009	7	Remove package TO-220FH
23-Feb-2009	8	Added $P_{TOT}$ value for TO-3PF $P_{TOT}$ ( <a href="#">Table 2: Absolute maximum ratings</a> )
23-Jul-2009	9	Added new figures: <a href="#">Figure 4: Safe operating area for TO-3PF</a> and <a href="#">Figure 5: Thermal impedance for TO-3PF</a>

**Please Read Carefully:**

Information in this document is provided solely in connection with ST products. STMicroelectronics NV and its subsidiaries ("ST") reserve the right to make changes, corrections, modifications or improvements, to this document, and the products and services described herein at any time, without notice.

All ST products are sold pursuant to ST's terms and conditions of sale.

Purchasers are solely responsible for the choice, selection and use of the ST products and services described herein, and ST assumes no liability whatsoever relating to the choice, selection or use of the ST products and services described herein.

No license, express or implied, by estoppel or otherwise, to any intellectual property rights is granted under this document. If any part of this document refers to any third party products or services it shall not be deemed a license grant by ST for the use of such third party products or services, or any intellectual property contained therein or considered as a warranty covering the use in any manner whatsoever of such third party products or services or any intellectual property contained therein.

**UNLESS OTHERWISE SET FORTH IN ST'S TERMS AND CONDITIONS OF SALE ST DISCLAIMS ANY EXPRESS OR IMPLIED WARRANTY WITH RESPECT TO THE USE AND/OR SALE OF ST PRODUCTS INCLUDING WITHOUT LIMITATION IMPLIED WARRANTIES OF MERCHANTABILITY, FITNESS FOR A PARTICULAR PURPOSE (AND THEIR EQUIVALENTS UNDER THE LAWS OF ANY JURISDICTION), OR INFRINGEMENT OF ANY PATENT, COPYRIGHT OR OTHER INTELLECTUAL PROPERTY RIGHT.**

**UNLESS EXPRESSLY APPROVED IN WRITING BY AN AUTHORIZED ST REPRESENTATIVE, ST PRODUCTS ARE NOT RECOMMENDED, AUTHORIZED OR WARRANTED FOR USE IN MILITARY, AIR CRAFT, SPACE, LIFE SAVING, OR LIFE SUSTAINING APPLICATIONS, NOR IN PRODUCTS OR SYSTEMS WHERE FAILURE OR MALFUNCTION MAY RESULT IN PERSONAL INJURY, DEATH, OR SEVERE PROPERTY OR ENVIRONMENTAL DAMAGE. ST PRODUCTS WHICH ARE NOT SPECIFIED AS "AUTOMOTIVE GRADE" MAY ONLY BE USED IN AUTOMOTIVE APPLICATIONS AT USER'S OWN RISK.**

Resale of ST products with provisions different from the statements and/or technical features set forth in this document shall immediately void any warranty granted by ST for the ST product or service described herein and shall not create or extend in any manner whatsoever, any liability of ST.

ST and the ST logo are trademarks or registered trademarks of ST in various countries.

Information in this document supersedes and replaces all information previously supplied.

The ST logo is a registered trademark of STMicroelectronics. All other names are the property of their respective owners.

© 2009 STMicroelectronics - All rights reserved

STMicroelectronics group of companies

Australia - Belgium - Brazil - Canada - China - Czech Republic - Finland - France - Germany - Hong Kong - India - Israel - Italy - Japan - Malaysia - Malta - Morocco - Philippines - Singapore - Spain - Sweden - Switzerland - United Kingdom - United States of America

[www.st.com](http://www.st.com)