

Ultra low drop BICMOS voltage regulator

Feature summary

- 3A Guaranteed output current
- Ultra low dropout voltage (200mV typ. @ 3A load, 40mV typ. @ 600mA load)
- Very low quiescent current (1.2mA typ. @ 3A load, 1µA max @ 25°C in off mode)
- Logic-controlled electronic shutdown
- Current and thermal internal limit
- $\pm 1.5\%$ Output voltage tolerance @ 25°C
- Fixed and ADJ output voltages: 1.22V, 1.8V, 2.5V, 3.3V, ADJ. (*see order code)
- Temperature range: -40 to 125°C
- Fast dynamic response to line and load changes
- Stable with ceramic capacitor (see paragraph 7.1, 7.2, 7.3)
- Available in PPAK and DPAK

Typical application

- Microprocessor power supply
- DSPs power supply
- Post regulators for switchin suppliers
- High efficiency linear regulator

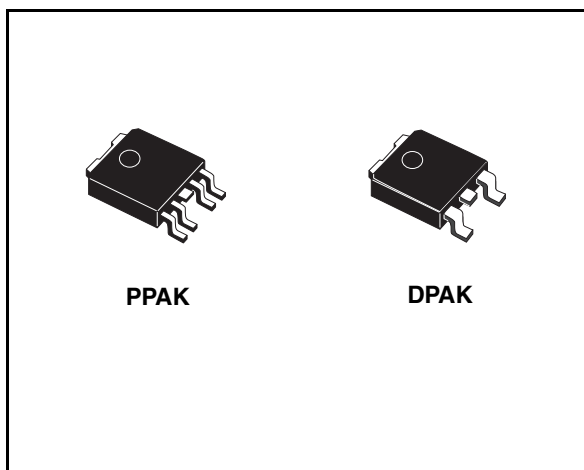

Description

The LD39300 is a fast ultra low drop linear regulator which operates from 2.5V to 6V input supply.

A wide range of output options are available. The low drop voltage, low noise, and ultra low quiescent current make it suitable for low voltage microprocessor and memory applications. The device is developed on a BiCMOS process which allows low quiescent current operation independently of output load current.

Order codes

Part numbers		Output voltage
DPAK	PPAK	
LD39300DT12-R		1.22V
LD39300DT18-R	LD39300PT18-R	1.8V
LD39300DT25-R	LD39300PT25-R	2.5V
LD39300DT33-R	LD39300PT33-R	3.3V
	LD39300PT-R	ADJ From 1.22 to 5.0V

Contents

1	Diagram	3
2	Pin configuration	4
3	Typical application circuits	5
4	Maximum ratings	7
5	Electrical characteristics	8
6	Typical performance characteristics	9
7	Application notes	11
	7.1 External capacitors	11
	7.2 Input capacitor	11
	7.3 Output capacitor	11
	7.4 Thermal note	11
	7.5 Inhibit input operation	11
8	Package mechanical data	12
9	Revision history	16

1 Diagram

Figure 1. Block diagram

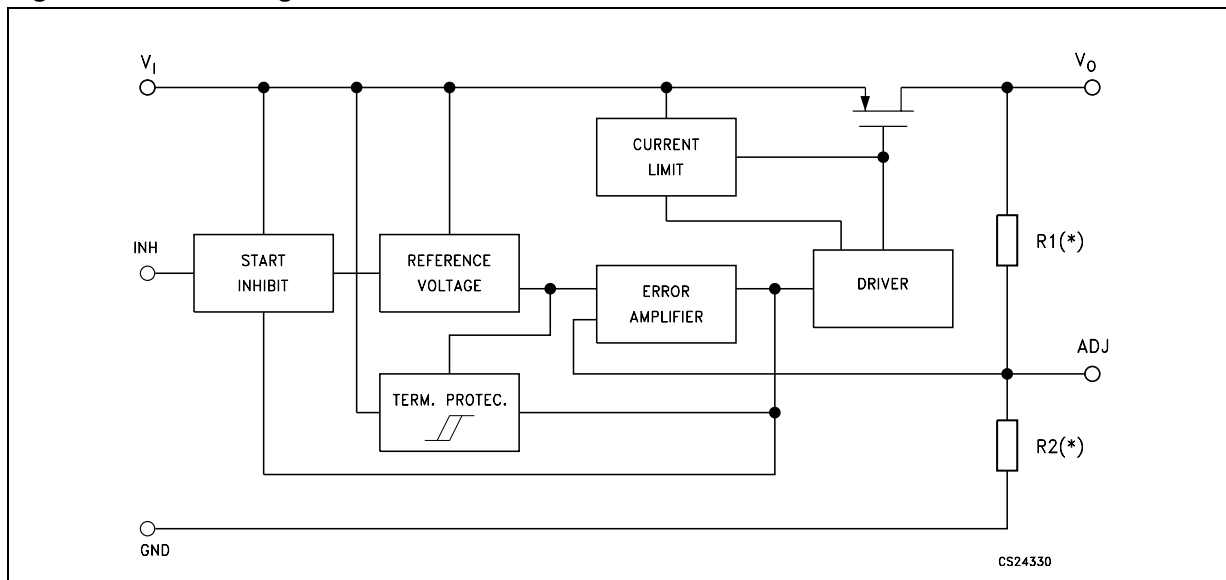

(*) Not present on ADJ Versions

2 Pin configuration

Figure 2. Pin connections (top view for DPAK and PPAK)

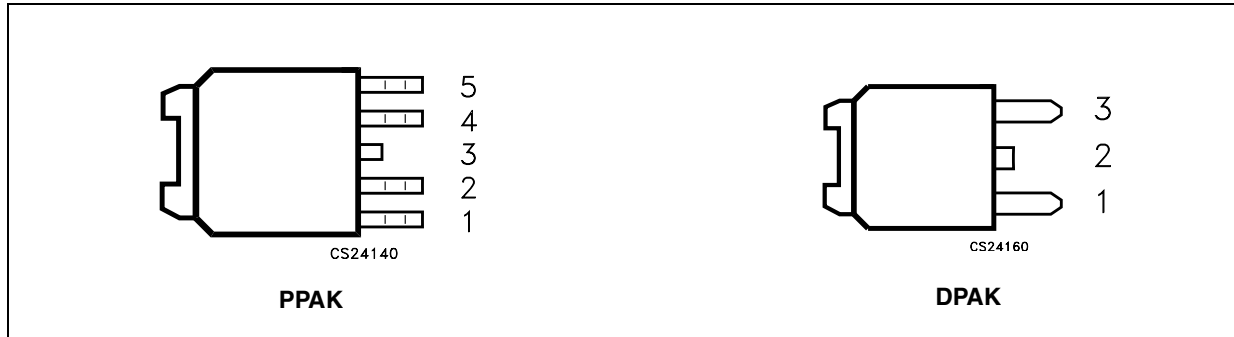

Table 1. Pin description

Pin N°		Symbol	Note
PPAK	DPAK		
5		V _{SENSE} /N.C.	For fixed versions: Not Connected on PPAK
		ADJ	For adjustable version: Error Amplifier Input pin for V _O from 1.22 to 5.0V
2	1	V _I	LDO Input Voltage; V _I from 2.5V to 6V, C _I =1μF must be located at a distance of not more than 0.5" from input pin.
4	3	V _O	LDO Output Voltage pins, with minimum C _O =4.7μF needed for stability (also refer to C _O vs. ESR stability chart)
1		V _{INH}	Inhibit Input Voltage: ON MODE when V _{INH} ≥ 2V, OFF MODE when V _{INH} ≤ 0.3V (Do not leave floating, not internally pulled down/up)
3	2	GND	Common ground

3 Typical application circuits

(C_1 and C_0 Capacitors must be placed as close as possible to the IC pins)

Figure 3. LD39300 Fixed version with inhibit

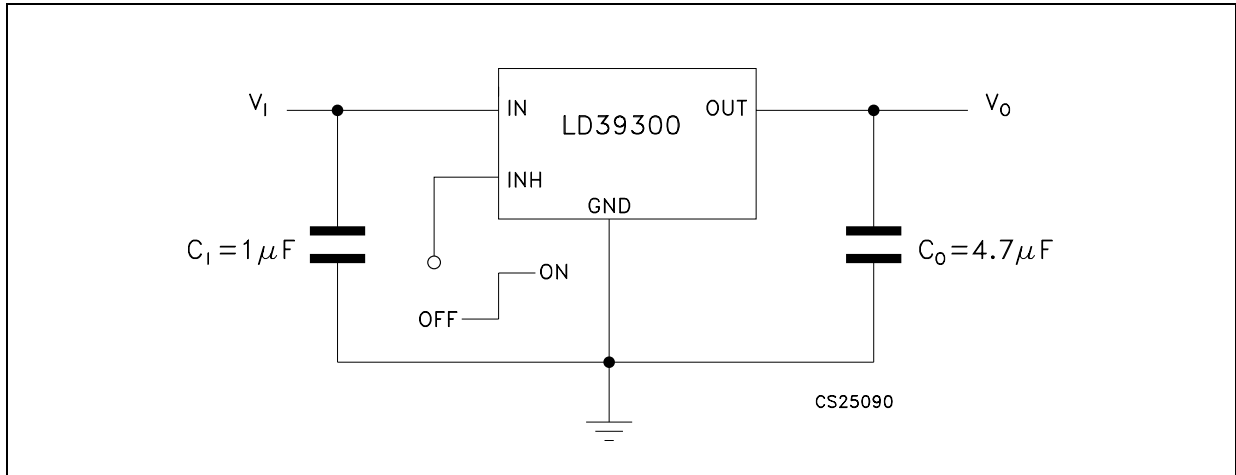

- 1 Inhibit Pin is not internally pulled down/up then it must not be left floating. Disable the device when connected to GND or to a positive voltage less than 0.3V

Figure 4. LD39300 Adjustable version

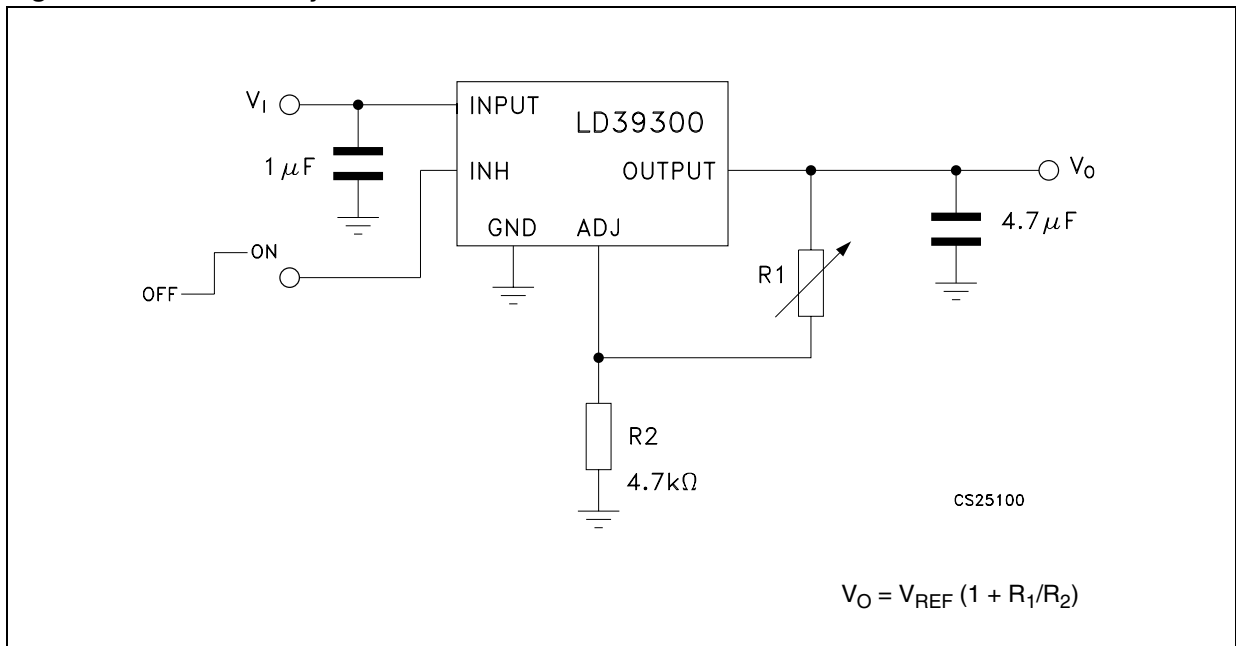

- 2 Set R_2 as close as possible to $4.7k\Omega$

Figure 5. LD39300 DPAK

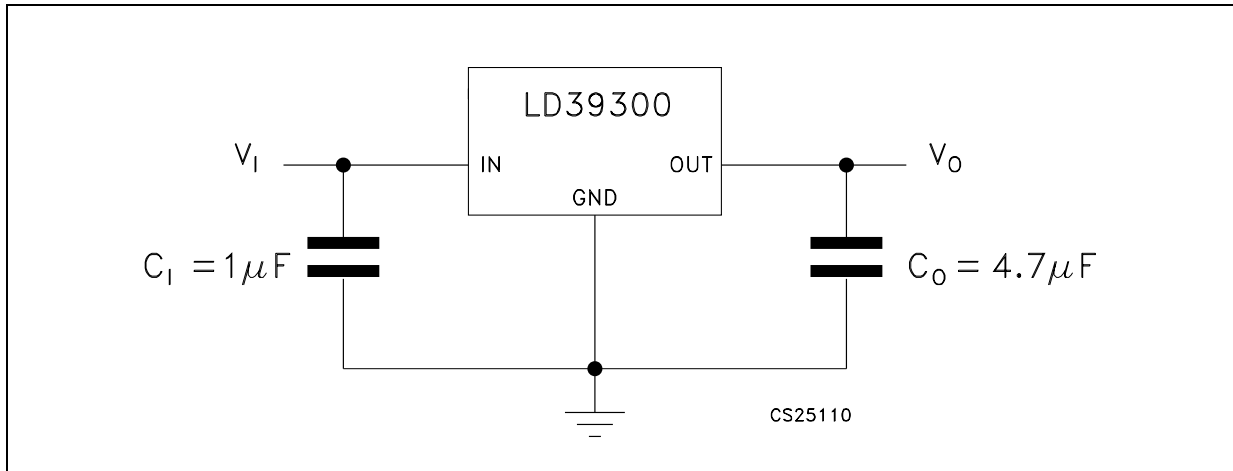
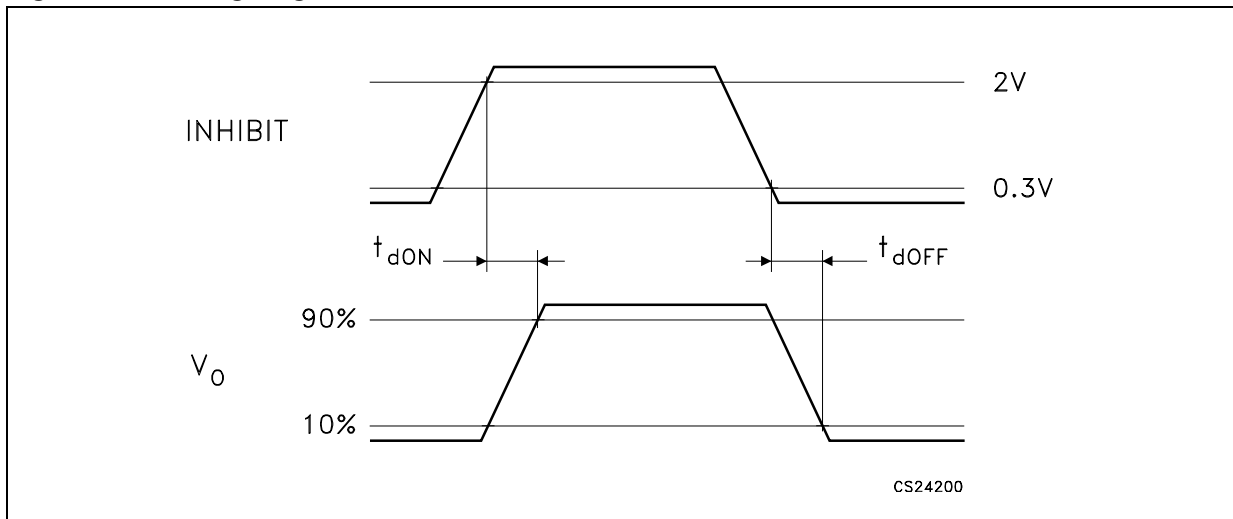

Figure 6. Timing diagram



4 Maximum ratings

Table 2. Absolute maximum ratings

Symbol	Parameter	Value	Unit
V_I	DC Input voltage	-0.3 to 6.5	V
V_{INH}	INHIBIT Input voltage	-0.3 to $V_I + 0.3$ (6.5V Max)	V
V_O	DC Output voltage	-0.3 to $V_I + 0.3$ (6.5V Max)	V
V_{ADJ}	ADJ Pin voltage	-0.3 to $V_I + 0.3$ (6.5V Max)	V
I_O	Output current	Internally Limited	mA
P_D	Power dissipation	Internally Limited	mW
T_{STG}	Storage temperature range	-50 to 150	°C
T_{OP}	Operating junction temperature range	-40 to 125	°C

Note: Absolute Maximum Ratings are those values beyond which damage to the device may occur. Functional operation under these conditions is not implied. All values are referred to GND.

Table 3. Thermal Data

Symbol	Parameter	PPAK	DPAK	Unit
R_{thJA}	Thermal resistance junction-ambient	100	100	°C/W
R_{thJC}	Thermal resistance junction-case	8	8	°C/W

5 Electrical characteristics

Table 4. Electrical characteristics

($T_J = 25^\circ\text{C}$, $V_I = V_O + 1\text{V}$, $C_I = 1\mu\text{F}$, $C_O = 4.7\mu\text{F}$, $I_{\text{LOAD}} = 10\text{mA}$, $V_{\text{INH}} = 2\text{V}$, unless otherwise specified)

Symbol	Parameter	Parameter	Min.	Typ.	Max.	Unit
V_I	Operating input voltage		2.5		6	V
V_O	Output voltage tolerance	$V_I = V_O + 1\text{V}$, $I_{\text{LOAD}} = 10\text{mA}$ to 3A	-1.5		1.5	% of $V_{\text{O(NOM)}}$
		$V_I = V_O + 1\text{V}$ to 6V , $I_{\text{LOAD}} = 10\text{mA}$ to 3A $T_J = -40$ to 125°C	-3		3	
V_{REF}	Reference voltage			1.22		V
ΔV_O	Output voltage LINE regulation	$V_I = V_O + 1\text{V}$ to 6V		0.04		%
		$V_I = V_O + 1\text{V}$ to 6V , $T_J = -40$ to 125°C		0.1	0.2	%
$\Delta V_O / \Delta I_{\text{LOAD}}$	Output voltage LOAD regulation	$I_{\text{LOAD}} = 10\text{mA}$ to 3A		0.06		% / A
		$I_{\text{LOAD}} = 10\text{mA}$ to 3A , $T_J = -40$ to 125°C		0.2	0.4	
V_{DROP}	Dropout voltage ($V_I - V_O$)	$I_{\text{LOAD}} = 600\text{mA}$, $T_J = -40$ to 125°C		40	80	mV
		$I_{\text{LOAD}} = 3\text{A}$, $T_J = -40$ to 125°C		200	400	
I_Q	Quiescent current: ON MODE	$I_{\text{LOAD}} = 10\text{mA}$ to 3A , $V_{\text{INH}} = 2\text{V}$ $T_J = -40$ to 125°C		1.2	2.5	mA
	Quiescent current: OFF MODE	$V_{\text{INH}} = 0.3\text{V}$			1	μA
		$V_{\text{INH}} = 0.3\text{V}$, $T_J = -40$ to 125°C			5	
Short Circuit Protection						
I_{SC}	Short circuit protection	$R_L = 0$		6		A
Inhibit Input						
V_{INH}	Inhibit threshold LOW	$V_I = 2.5$ to 6V OFF $T_J = -40$ to 125°C			0.3	V
	Inhibit threshold HIGH		2			
$T_{\text{D-OFF}}$	Current limit	$I_{\text{LOAD}} = 3\text{A}$, $V_O = 3.3\text{V}$		20		μs
$T_{\text{D-ON}}$	Current limit	$I_{\text{LOAD}} = 3\text{A}$, $V_O = 3.3\text{V}$		20		
I_{INH}	Inhibit input current ⁽¹⁾	$V_I = 6\text{V}$, $V_{\text{INH}} = 0$ to 6V		± 0.1	± 1	μA
AC Parameters						
SVR	Supply voltage rejection	$V_I = 4.5 \pm 1\text{V}$, $V_O = 3.3\text{V}$, $I_{\text{LOAD}} = 10\text{mA}$,	$f = 120\text{Hz}$		65	dB
			$f = 1\text{kHz}$		55	
e_N	Output noise voltage	$B_W = 10\text{Hz}$ to 100kHz , $C_O = 4.7\mu\text{F}$, $V_O = 2.5\text{V}$		100		μV_{RMS}
T_{SHDN}	Thermal shutdown OFF			170		$^\circ\text{C}$
	Hysteresis			10		

1. Guaranteed by design

6 Typical performance characteristics

($T_J = 25^\circ\text{C}$, $V_I = V_O + 1\text{V}$, $C_I = 1\mu\text{F}$, $C_O = 4.7\mu\text{F}$, $I_{\text{LOAD}} = 10\text{mA}$, $V_{\text{INH}} = V_I$, unless otherwise specified)

Figure 7. Output voltage vs temperature

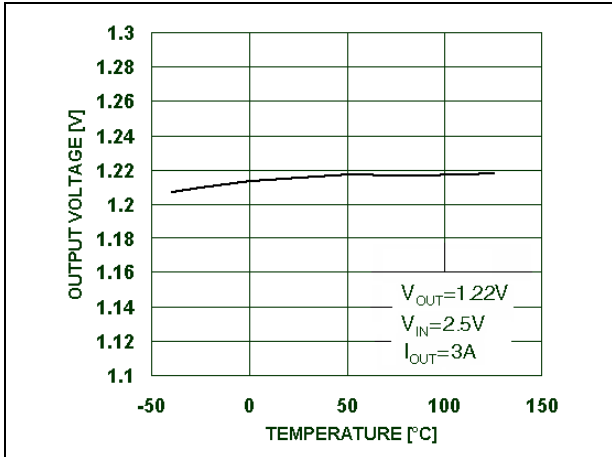

Figure 8. Dropout voltage vs temperature

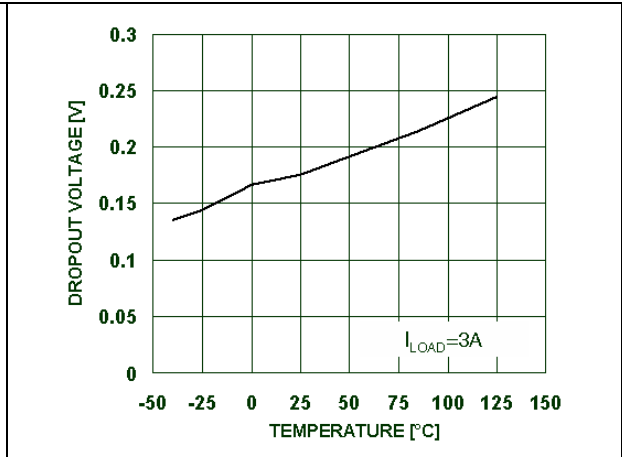

Figure 9. Dropout voltage vs output current

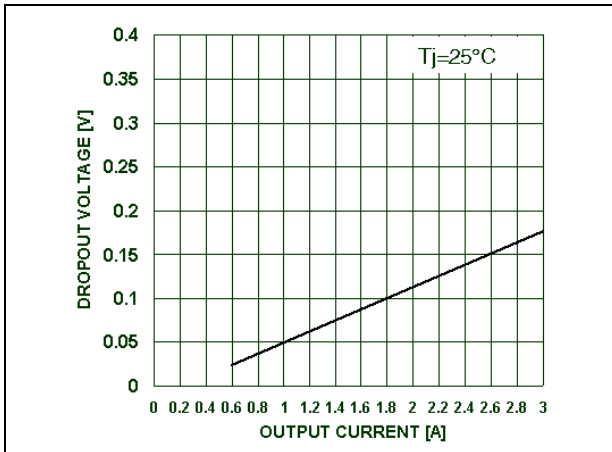

Figure 10. Quiescent current vs temperature

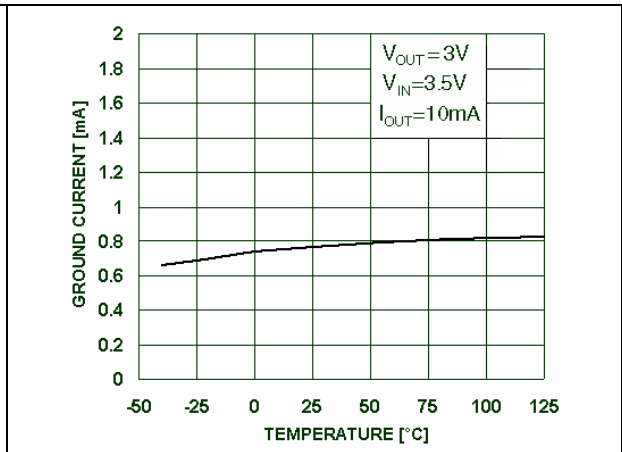

Figure 11. Quiescent current vs temperature

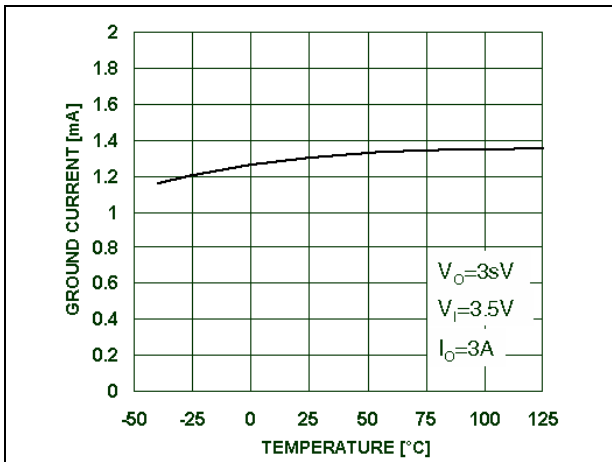

Figure 12. Short circuit current vs temperature

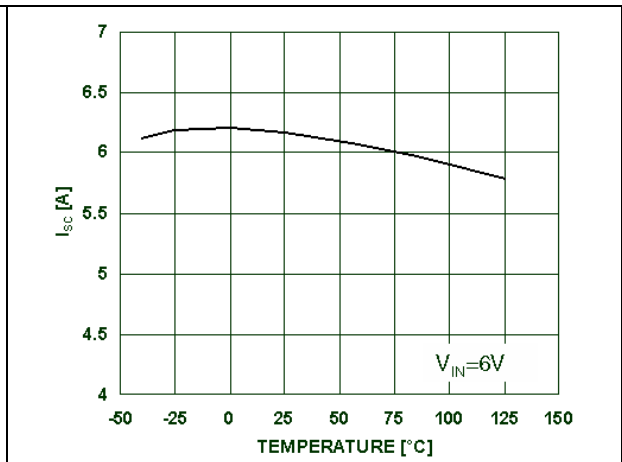

Figure 13. Output voltage vs input voltage

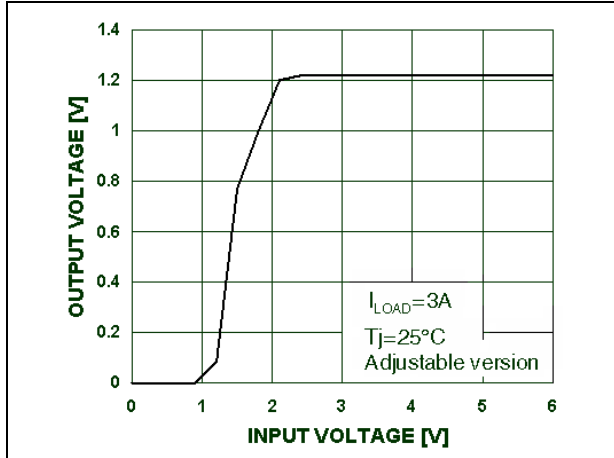

Figure 14. Stability region vs C_O & ESR

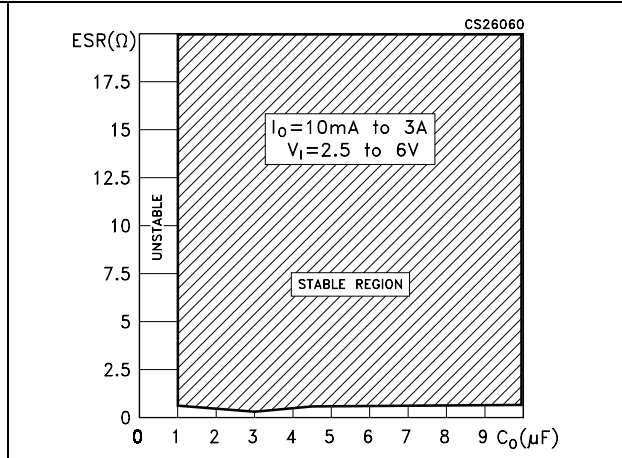

Figure 15. Stability region vs C_O & ESR (low ESR zoom area)

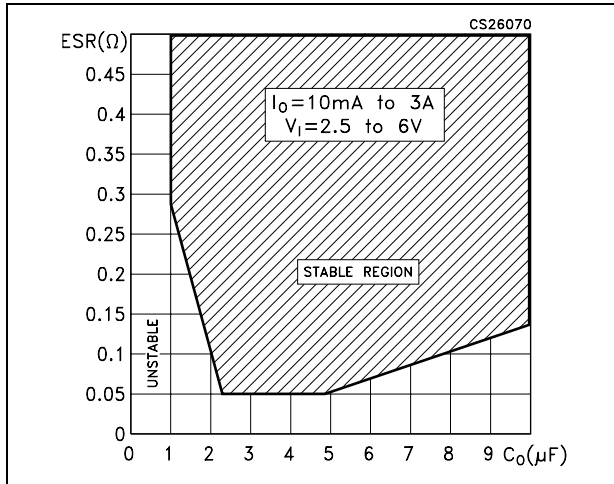

Figure 16. Load transient (fall time)

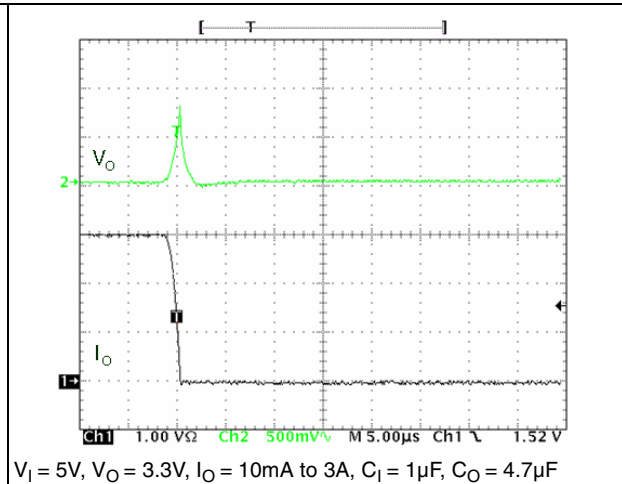

Figure 17. Load transient (rise time)

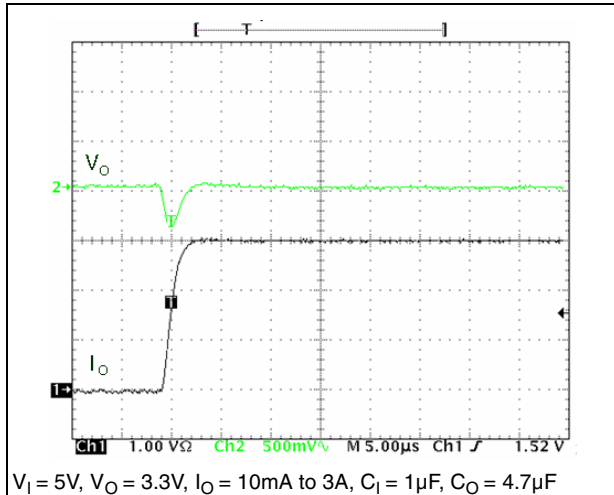
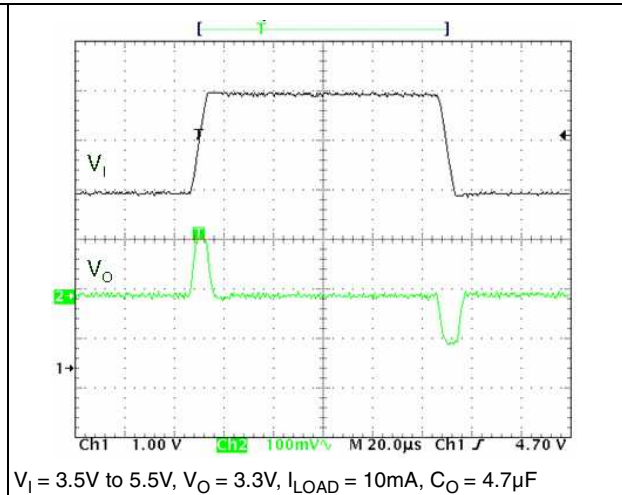

Figure 18. Line transient



7 Application notes

7.1 External capacitors

The LD39300 requires external capacitors for regulator stability. These capacitors must be selected to meet the requirements of minimum capacitance and equivalent series resistance (see [Figure 14](#), [Figure 15](#)). The input/output capacitors must be located less than 1cm from the relative pins and connected directly to the input/output ground pins using traces which have no other currents flowing through them. Any good quality of Ceramic or Electrolytic capacitors can be used.

7.2 Input capacitor

An input capacitor whose minimum value is 1 μ F is required with the LD39300 (amount of capacitance can be increased without limit). This capacitor must be located a distance of not more than 1cm from the input pin of the device and returned to a clean analog ground. Any good quality ceramic, tantalum or film capacitors can be used for this capacitor.

7.3 Output capacitor

It is possible to use Ceramic or Tantalum capacitors but the output capacitor must meet the requirement for minimum amount of capacitance and E.S.R. (equivalent series resistance) value. A minimum capacitance of 4.7 μ F is a good choice to guarantee the stability of the regulator. Anyway, other C_O values can be used according to the ([Figure 14](#), [Figure 15](#)) showing the allowable ESR range as a function of the output capacitance. This curve represents the stability region over the full temperature and I_O range.

7.4 Thermal note

The output capacitor must maintain its ESR in the stable region over the full operating temperature range to assure stability. Also, capacitors tolerance and variation with temperature must be kept in consideration in order to assure the minimum amount of capacitance at all times.

7.5 Inhibit input operation

The inhibit pin can be used to turn OFF the regulator when pulled down, so drastically reducing the current consumption down to less than 1 μ A. When the inhibit feature is not used, this pin must be tied to V_I to keep the regulator output ON at all times. To assure proper operation, the signal source used to drive the inhibit pin must be able to swing above and below the specified thresholds listed in the electrical characteristics section (V_{IH} V_{IL}). The inhibit pin must not be left floating because it is not internally pulled down/up.

8 Package mechanical data

In order to meet environmental requirements, ST offers these devices in ECOPACK® packages. These packages have a Lead-free second level interconnect. The category of second Level Interconnect is marked on the package and on the inner box label, in compliance with JEDEC Standard JESD97. The maximum ratings related to soldering conditions are also marked on the inner box label. ECOPACK is an ST trademark. ECOPACK specifications are available at: www.st.com.

PPAK MECHANICAL DATA

DIM.	mm.			inch		
	MIN.	TYP	MAX.	MIN.	TYP.	MAX.
A	2.2		2.4	0.086		0.094
A1	0.9		1.1	0.035		0.043
A2	0.03		0.23	0.001		0.009
B	0.4		0.6	0.015		0.023
B2	5.2		5.4	0.204		0.212
C	0.45		0.6	0.017		0.023
C2	0.48		0.6	0.019		0.023
D	6		6.2	0.236		0.244
D1		5.1			0.201	
E	6.4		6.6	0.252		0.260
E1		4.7			0.185	
e		1.27			0.050	
G	4.9		5.25	0.193		0.206
G1	2.38		2.7	0.093		0.106
H	9.35		10.1	0.368		0.397
L2		0.8	1		0.031	0.039
L4	0.6		1	0.023		0.039
L5	1			0.039		
L6		2.8			0.110	

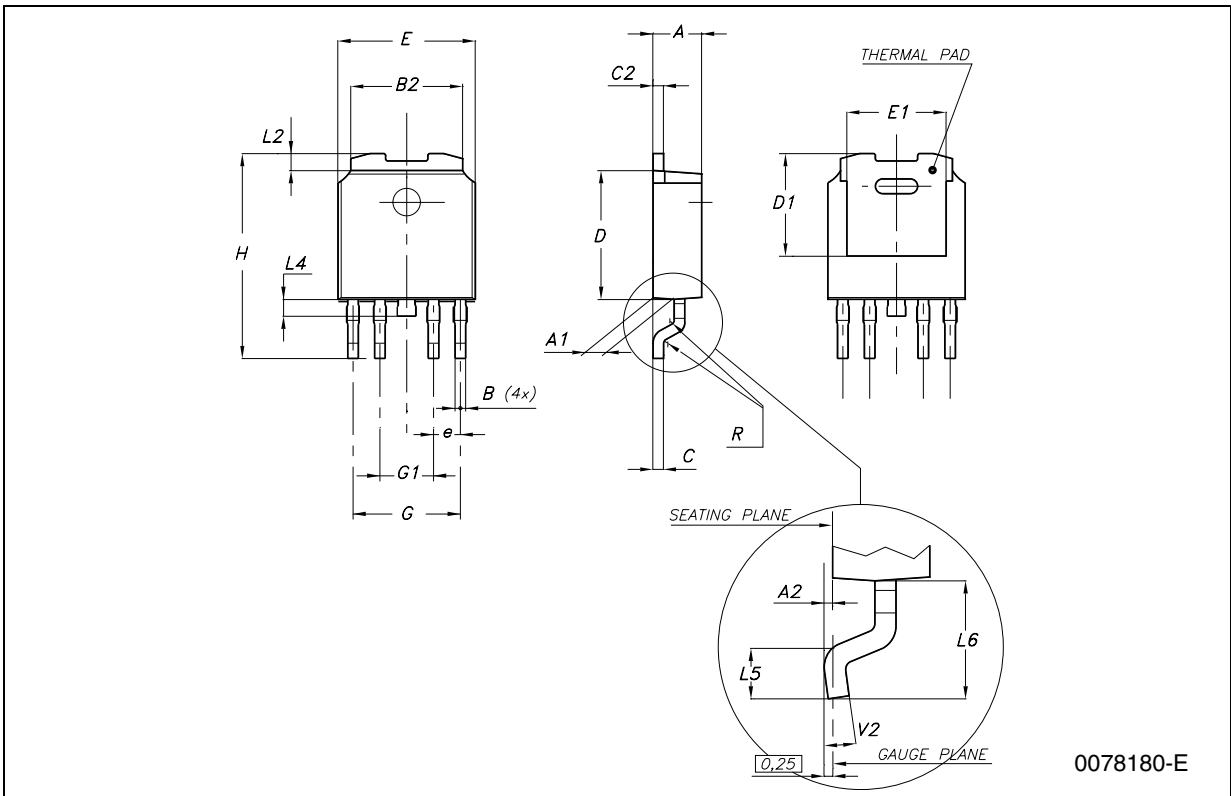

0078180-E

DPAK MECHANICAL DATA

DIM.	mm.			inch		
	MIN.	TYP	MAX.	MIN.	TYP.	MAX.
A	2.2		2.4	0.086		0.094
A1	0.9		1.1	0.035		0.043
A2	0.03		0.23	0.001		0.009
B	0.64		0.9	0.025		0.035
b4	5.2		5.4	0.204		0.212
C	0.45		0.6	0.017		0.023
C2	0.48		0.6	0.019		0.023
D	6		6.2	0.236		0.244
D1		5.1			0.200	
E	6.4		6.6	0.252		0.260
E1		4.7			0.185	
e		2.28			0.090	
e1	4.4		4.6	0.173		0.181
H	9.35		10.1	0.368		0.397
L	1			0.039		
(L1)		2.8			0.110	
L2		0.8			0.031	
L4	0.6		1	0.023		0.039

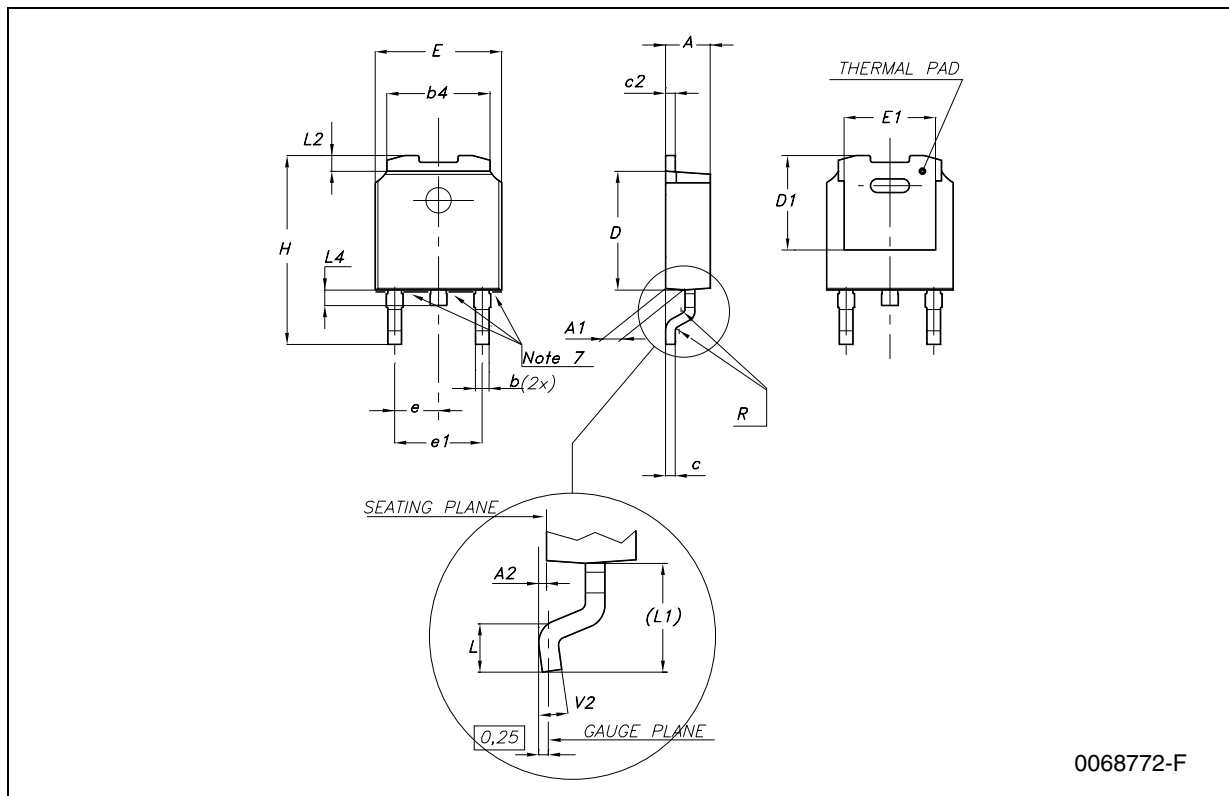

Tape & Reel DPAK-PPAK MECHANICAL DATA

DIM.	mm.			inch		
	MIN.	TYP	MAX.	MIN.	TYP.	MAX.
A			330			12.992
C	12.8	13.0	13.2	0.504	0.512	0.519
D	20.2			0.795		
N	60			2.362		
T			22.4			0.882
Ao	6.80	6.90	7.00	0.268	0.272	0.276
Bo	10.40	10.50	10.60	0.409	0.413	0.417
Ko	2.55	2.65	2.75	0.100	0.104	0.105
Po	3.9	4.0	4.1	0.153	0.157	0.161
P	7.9	8.0	8.1	0.311	0.315	0.319

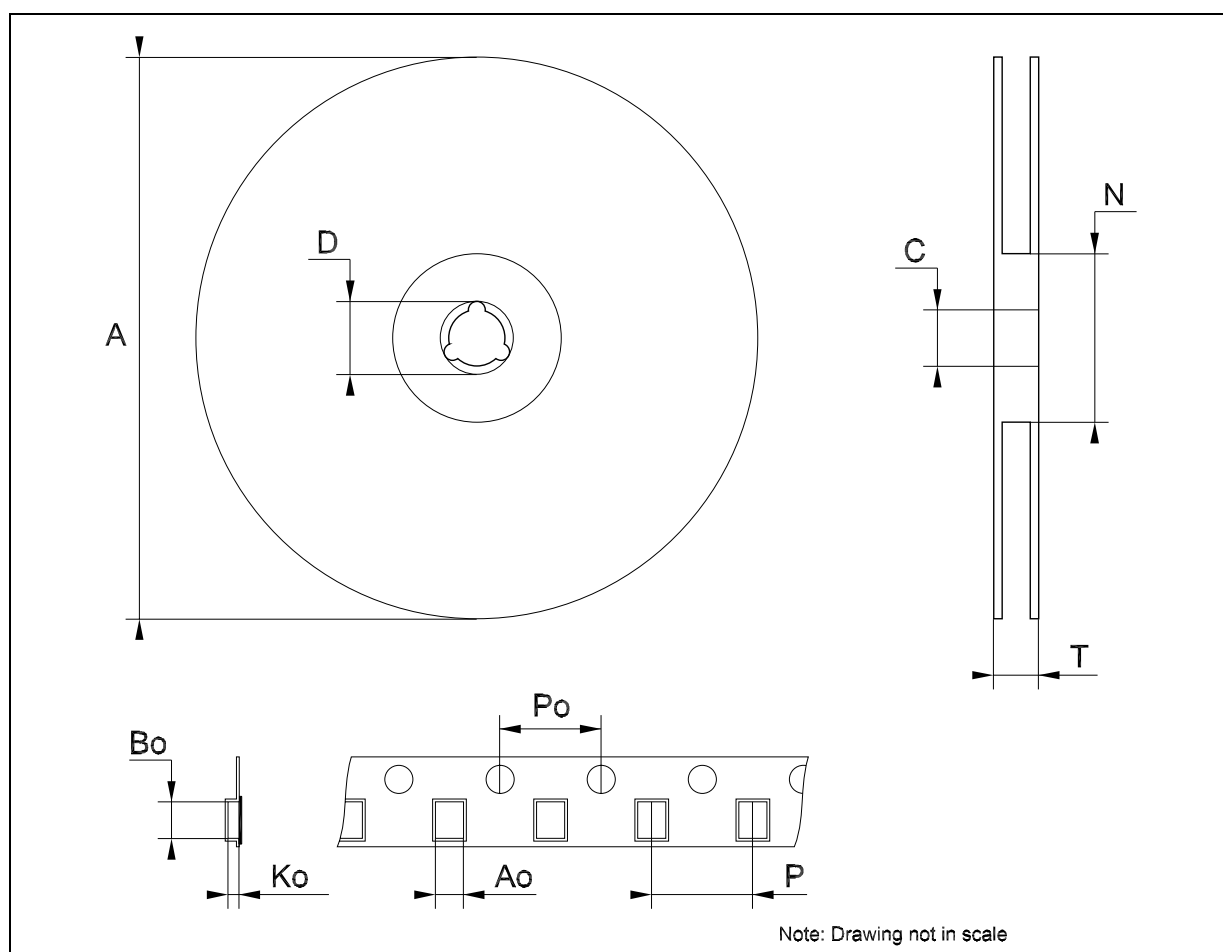

9 Revision history

Table 5. Revision history

Date	Revision	Changes
26-Jan-2007	1	Initial release.

Please Read Carefully:

Information in this document is provided solely in connection with ST products. STMicroelectronics NV and its subsidiaries ("ST") reserve the right to make changes, corrections, modifications or improvements, to this document, and the products and services described herein at any time, without notice.

All ST products are sold pursuant to ST's terms and conditions of sale.

Purchasers are solely responsible for the choice, selection and use of the ST products and services described herein, and ST assumes no liability whatsoever relating to the choice, selection or use of the ST products and services described herein.

No license, express or implied, by estoppel or otherwise, to any intellectual property rights is granted under this document. If any part of this document refers to any third party products or services it shall not be deemed a license grant by ST for the use of such third party products or services, or any intellectual property contained therein or considered as a warranty covering the use in any manner whatsoever of such third party products or services or any intellectual property contained therein.

UNLESS OTHERWISE SET FORTH IN ST'S TERMS AND CONDITIONS OF SALE ST DISCLAIMS ANY EXPRESS OR IMPLIED WARRANTY WITH RESPECT TO THE USE AND/OR SALE OF ST PRODUCTS INCLUDING WITHOUT LIMITATION IMPLIED WARRANTIES OF MERCHANTABILITY, FITNESS FOR A PARTICULAR PURPOSE (AND THEIR EQUIVALENTS UNDER THE LAWS OF ANY JURISDICTION), OR INFRINGEMENT OF ANY PATENT, COPYRIGHT OR OTHER INTELLECTUAL PROPERTY RIGHT.

UNLESS EXPRESSLY APPROVED IN WRITING BY AN AUTHORIZED ST REPRESENTATIVE, ST PRODUCTS ARE NOT RECOMMENDED, AUTHORIZED OR WARRANTED FOR USE IN MILITARY, AIR CRAFT, SPACE, LIFE SAVING, OR LIFE SUSTAINING APPLICATIONS, NOR IN PRODUCTS OR SYSTEMS WHERE FAILURE OR MALFUNCTION MAY RESULT IN PERSONAL INJURY, DEATH, OR SEVERE PROPERTY OR ENVIRONMENTAL DAMAGE. ST PRODUCTS WHICH ARE NOT SPECIFIED AS "AUTOMOTIVE GRADE" MAY ONLY BE USED IN AUTOMOTIVE APPLICATIONS AT USER'S OWN RISK.

Resale of ST products with provisions different from the statements and/or technical features set forth in this document shall immediately void any warranty granted by ST for the ST product or service described herein and shall not create or extend in any manner whatsoever, any liability of ST.

ST and the ST logo are trademarks or registered trademarks of ST in various countries.

Information in this document supersedes and replaces all information previously supplied.

The ST logo is a registered trademark of STMicroelectronics. All other names are the property of their respective owners.

© 2007 STMicroelectronics - All rights reserved

STMicroelectronics group of companies

Australia - Belgium - Brazil - Canada - China - Czech Republic - Finland - France - Germany - Hong Kong - India - Israel - Italy - Japan - Malaysia - Malta - Morocco - Singapore - Spain - Sweden - Switzerland - United Kingdom - United States of America

www.st.com