

Off-line all-primary-sensing switching regulator

Features

- Constant voltage and constant current output regulation (CV/CC) with no optocoupler
- Tight regulation also in presence of heavy load transients
- 800 V avalanche rugged internal power section
- Quasi-resonant (QR) operation
- Low standby power consumption
- Automatic self-supply
- Input voltage feedforward for mains-independent cc regulation
- Output cable drop compensation
- SO16 package

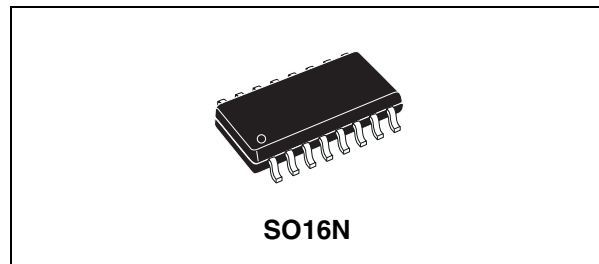

Applications

- AC-DC chargers for mobile phones and other hand-held equipments
- Compact SMPS that requires a precise current and/or voltage regulation

Description

ALTAIR05T-800 is a high-voltage all-primary sensing switcher intended for operating directly from the rectified mains with minimum external parts. It combines a high-performance low-voltage PWM controller chip and an 800 V avalanche-rugged power section in the same package.

Figure 1. Block diagram

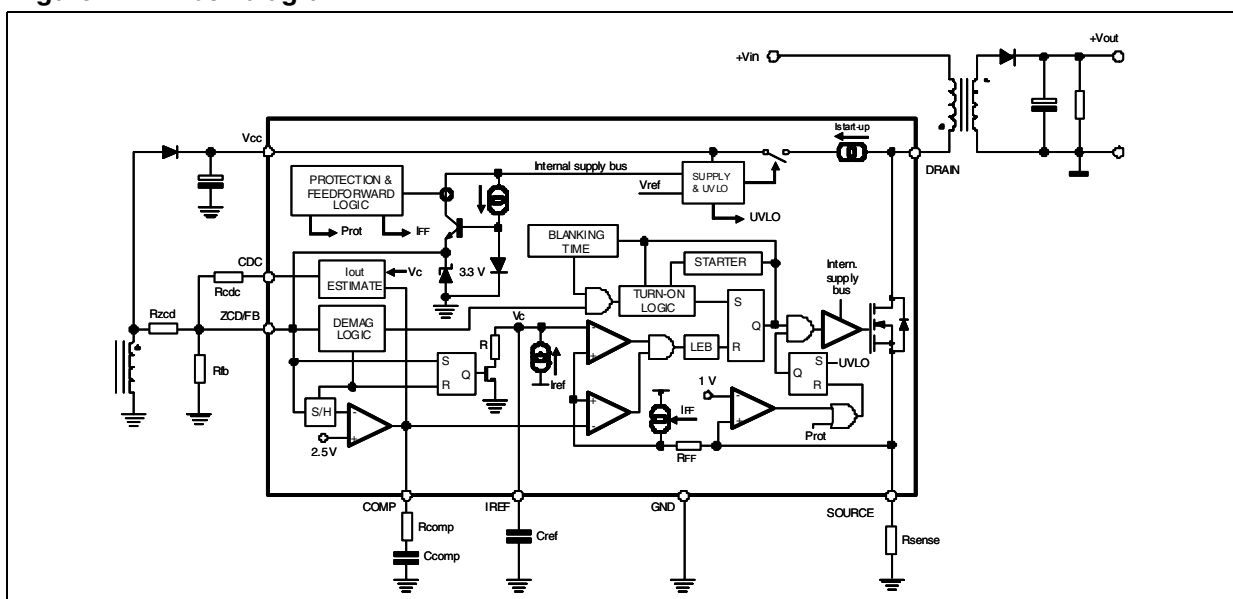

Contents

1	Device description	3
2	Pin connection	4
3	Maximum ratings	6
3.1	Absolute maximum ratings	6
3.2	Thermal data	6
4	Electrical characteristics	7
5	Application information	11
5.1	Power section and gate driver	12
5.2	High-voltage start-up generator	12
5.3	Zero current detection and triggering block	13
5.4	Constant voltage operation	15
5.5	Constant current operation	15
5.6	Voltage feedforward block	17
5.7	Cable drop compensation (CDC)	18
5.8	Burst-mode operation at no load or very light load	20
5.9	Soft-start and starter block	20
5.10	Hiccup mode OCP	21
5.11	Layout recommendations	21
6	Typical application	23
7	Package mechanical data	24
8	Order codes	26
9	Revision history	27

1 Device description

The device combines two silicon in the same package: a low voltage PWM controller and an 800 V avalanche rugged power section.

The controller chip is a current-mode specifically designed for offline quasi-resonant flyback converters.

The device features a unique characteristic: it is capable of providing constant output voltage (CV) and constant output current (CC) regulation using primary-sensing feedback. This eliminates the need for the optocoupler, the secondary voltage reference, as well as the current sensor, still maintaining quite accurate regulation also in presence of heavy load transients. Additionally, it is possible to compensate the voltage drop on the output cable, so as to improve CV regulation on the external accessible terminals.

Quasi-resonant operation is guaranteed by means of a transformer demagnetization sensing input that turns on the power section. The same input serves also the output voltage monitor, to perform CV regulation, and the input voltage monitor, to achieve mains-independent CC regulation (line voltage feedforward).

The maximum switching frequency is top-limited below 166 kHz, so that at medium-light load a special function automatically lowers the operating frequency still maintaining the valley switching operation. At very light load, the device enters a controlled burst-mode operation that, along with the built-in high-voltage start-up circuit and the low operating current, helps minimize the standby power.

Although an auxiliary winding is required in the transformer to correctly perform CV/CC regulation, the chip is able to power itself directly from the rectified mains. This is useful especially during CC regulation, where the flyback voltage generated by the winding drops below UVLO threshold. However, if ultra-low no-load input consumption is required to comply with the most stringent energy-saving recommendations, then the device needs to be powered via the auxiliary winding.

In addition to these functions that optimize power handling under different operating conditions, the device offers protection features that considerably increase end-product's safety and reliability: auxiliary winding disconnection - or brownout – detection and shorted secondary rectifier - or transformer's saturation – detection. All of them are auto restart mode.

2 Pin connection

Figure 2. Pin connection (top view)

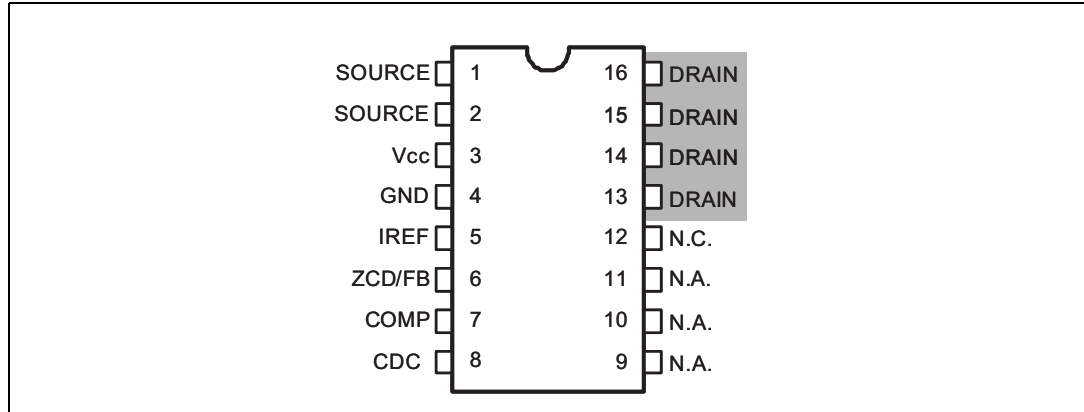

Note: The copper area for heat dissipation has to be designed under the drain pins

Table 1. Pin functions

N.	Name	Function
1, 2	SOURCE	Power section source and input to the PWM comparator. The current flowing in the MOSFET is sensed through a resistor connected between the pin and GND. The resulting voltage is compared with an internal reference (0.75V max.) to determine MOSFET's turn-off. The pin is equipped with 250 ns blanking time after the gate-drive output goes high for improved noise immunity. If a second comparison level located at 1V is exceeded the IC is stopped and restarted after Vcc has dropped below 5V.
3	Vcc	Supply Voltage of the device. An electrolytic capacitor, connected between this pin and ground, is initially charged by the internal high-voltage start-up generator; when the device is running the same generator keeps it charged in case the voltage supplied by the auxiliary winding is not sufficient. This feature is disabled in case a protection is tripped. Sometimes a small bypass capacitor (0.1 μF typ.) to GND might be useful to get a clean bias voltage for the signal part of the IC.
4	GND	Ground. Current return for both the signal part of the IC and the gate drive. All of the ground connections of the bias components should be tied to a trace going to this pin and kept separate from any pulsed current return.
5	IREF	CC regulation loop reference voltage. An external capacitor has to be connected between this pin and GND. An internal circuit develops a voltage on this capacitor that is used as the reference for the MOSFET's peak drain current during CC regulation. The voltage is automatically adjusted to keep the average output current constant.

Table 1. Pin functions (continued)

N.	Name	Function
6	ZCD/FB	Transformer's demagnetization sensing for quasi-resonant operation. Input/output voltage monitor. A negative-going edge triggers MOSFET's turn-on. The current sourced by the pin during ON-time is monitored to get an image of the input voltage to the converter, in order to compensate the internal delay of the current sensing circuit and achieve a CC regulation independent of the mains voltage. If this current does not exceed 50µA, either a floating pin or an abnormally low input voltage is assumed, the device is stopped and restarted after Vcc has dropped below 5V. Still, the pin voltage is sampled-and-held right at the end of transformer's demagnetization to get an accurate image of the output voltage to be fed to the inverting input of the internal, transconductance-type, error amplifier, whose non-inverting input is referenced to 2.5V. Please note that the maximum I _{ZCD/FB} sunk/sourced current has to not exceed ±2 mA (AMR) in all the Vin range conditions (85-265 Vac). No capacitor is allowed between the pin and the auxiliary transformer.
7	COMP	Output of the internal transconductance error amplifier. The compensation network is placed between this pin and GND to achieve stability and good dynamic performance of the voltage control loop.
8	CDC	Cable drop compensation input. During CV regulation this pin, capable of sinking current, provides a voltage lower than the internal reference voltage (2.5V) by an amount proportional to the dc load current. By connecting a resistor between this pin and ZCD/FB, the CV regulation setpoint is increased proportionally. This allows that the voltage drop across the output cable be compensated and, ideally, that zero load regulation at the externally available terminals be achieved. Leave the pin open if the function is not used.
9-11	N.A	Not available. These pins must be left not connected
12	N.C	Not internally connected. Provision for clearance on the PCB to meet safety requirements.
13 to 16	DRAIN	Drain connection of the internal power section. The internal high-voltage start-up generator sinks current from this pin as well. Pins connected to the internal metal frame to facilitate heat dissipation.

3 Maximum ratings

3.1 Absolute maximum ratings

Table 2. Absolute maximum ratings

Symbol	Pin	Parameter	Value	Unit
V_{DS}	1,2, 13-16	Drain-to-source (ground) voltage	-1 to 800	V
I_D	1,2, 13-16	Drain current	1	A
E_{av}	1,2, 13-16	Single pulse avalanche energy ($T_j = 25^\circ\text{C}$, $I_D = 1\text{A}$)	50	mJ
V_{CC}	3	Supply voltage ($I_{CC} < 25\text{mA}$)	Self limiting	V
$I_{ZCD/FB}$	6	Zero current detector current	± 2	mA
---	7, 8	Analog inputs and outputs	-0.3 to 3.6	V
I_{CDC}	8	Maximum sunk current	200	μA
P_{tot}		Power dissipation @ $T_A = 50^\circ\text{C}$	0.9	W
T_j		Junction temperature range	-25 to 150	$^\circ\text{C}$
T_{stg}		Storage temperature	-55 to 150	$^\circ\text{C}$

3.2 Thermal data

Table 3. Thermal data

Symbol	Parameter	Max. value	Unit
$R_{th\ j-pin}$	Thermal resistance, junction-to-pin	10	$^\circ\text{C}/\text{W}$
$R_{th\ j-amb}$	Thermal resistance, junction-to-ambient	110	

4 Electrical characteristics

($T_J = -25$ to 125 °C, $V_{CC} = 14$ V; unless otherwise specified)

Table 4. Electrical characteristics

Symbol	Parameter	Test condition	Min.	Typ.	Max.	Unit
Power section						
$V_{(BR)DSS}$	Drain-source breakdown	$I_D < 100 \mu A$; $T_J = 25$ °C	800			V
I_{DSS}	Off state drain current	$V_{DS} = 750$ V; $T_J = 125$ °C (See Figure 4 and note)			80	μA
$R_{DS(on)}$	Drain-source ON-state resistance	$I_D = 100$ mA; $T_J = 25$ °C		11	14	Ω
		$I_D = 100$ mA; $T_J = 125$ °C		22	28	
C_{oss}	Effective (energy-related) output capacitance	(See Figure 3)				
High-voltage start-up generator						
V_{Start}	Min. Drain start voltage	$I_{charge} < 100 \mu A$	40	50	60	V
I_{charge}	V_{CC} startup charge current	$V_{DRAIN} > V_{Start}$; $V_{CC} < V_{CCOn}$ $T_J = 25$ °C	4	5.5	7	mA
$V_{CCrestart}$	V_{CC} restart voltage (V_{CC} falling)	(1)	9.5	10.5	11.5	V
		After protection tripping		5		
Supply voltage						
V_{CC}	Operating range	After turn-on	11.5		23	V
V_{CCOn}	Turn-on threshold	(1)	12	13	14	V
V_{CCOff}	Turn-off threshold	(1)	9	10	11	V
V_Z	Zener voltage	$I_{CC} = 20$ mA	23	25	27	V
Supply current						
$I_{CCstart-up}$	Start-up current	(See Figure 5)		200	300	μA
I_q	Quiescent current	(See Figure 6)		1	1.4	mA
I_{CC}	Operating supply current @ 50 kHz	(See Figure 7)		1.4	1.7	mA
$I_{q(fault)}$	Fault quiescent current	During hiccup and brownout (See Figure 8)		250	350	μA
Start-up timer						
T_{START}	Start timer period		100	125	175	μs
$T_{RESTART}$	Restart timer period during burst mode		400	500	700	μs
Zero current detector						
I_{ZCDb}	Input bias current	$V_{ZCD} = 0.1$ to 3 V		0.1	1	μA
V_{ZCDH}	Upper clamp voltage	$I_{ZCD} = 1$ mA	3.0	3.3	3.6	V

Table 4. Electrical characteristics (continued)

Symbol	Parameter	Test condition	Min.	Typ.	Max.	Unit
V _{ZCDL}	Lower clamp voltage	I _{ZCD} = - 1 mA	-90	-60	-30	mV
V _{ZCDA}	Arming voltage	positive-going edge	100	110	120	mV
V _{ZCDT}	Triggering voltage	negative-going edge	50	60	70	mV
I _{ZCDON}	Min. source current during MOSFET ON-time		-25	-50	-75	μA
T _{BLANK}	Trigger blanking time after MOSFET's turn-off	V _{COMP} ≥ 1.3V		6		μs
		V _{COMP} = 0.9V		30		
Line feedforward						
R _{FF}	Equivalent feedforward resistor	I _{ZCD} = 1mA		45		Ω
Transconductance error amplifier						
V _{REF}	Voltage reference	T _J = 25°C ⁽¹⁾	2.46	2.5	2.54	V
		T _J = -25 to 125°C and V _{CC} =12V to 23V ⁽¹⁾	2.42		2.58	
gm	Transconductance	ΔI _{COMP} = ±10 μA V _{COMP} = 1.65 V	1.3	2.2	3.2	mS
G _v	Voltage gain	Open loop		73		dB
GB	Gain-bandwidth product			500		KHz
I _{COMP}	Source current	V _{ZCD} = 2.3V, V _{COMP} = 1.65V	70	100		μA
	Sink current	V _{ZCD} = 2.7V, V _{COMP} = 1.65V	400	750		μA
V _{COMPH}	Upper COMP voltage	V _{ZCD} = 2.3 V		2.7		V
V _{COMPL}	Lower COMP voltage	V _{ZCD} = 2.7 V		0.7		V
V _{COMPBM}	Burst-mode threshold			1		V
Hys	Burst-mode hysteresis			65		mV
CDC function						
V _{CDC}	CDC voltage reference	V _{COMP} = 1.1V, I _{CDC} = 1μA ⁽¹⁾	2.4	2.5	2.6	V
Current reference						
V _{IREFx}	Maximum value	V _{COMP} = V _{COMPL} ⁽¹⁾	1.5	1.6	1.7	V
V _{CREF}	Current reference voltage		0.192	0.2	0.208	V
Current sense						
t _{LEB}	Leading-edge blanking		200	250	300	ns
t _{d(H-L)}	Delay-to-output			300		ns
V _{CSx}	Max. clamp value	dV _{CS} /d _t = 200 mV/μs ⁽¹⁾	0.7	0.75	0.8	V
V _{CSdis}	Hiccup-mode OCP level	⁽¹⁾	0.92	1	1.08	V

1. Parameters tracking each other

Figure 3. C_{OSS} output capacitance variation

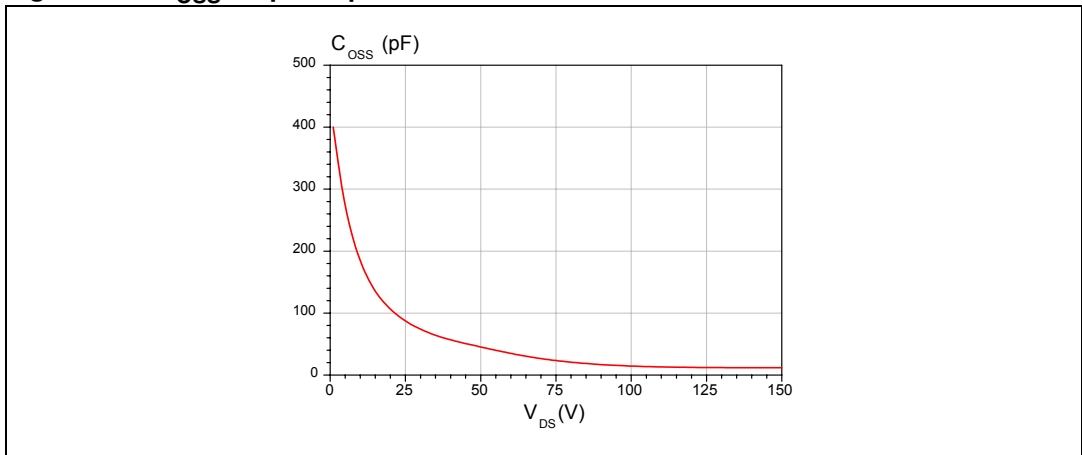
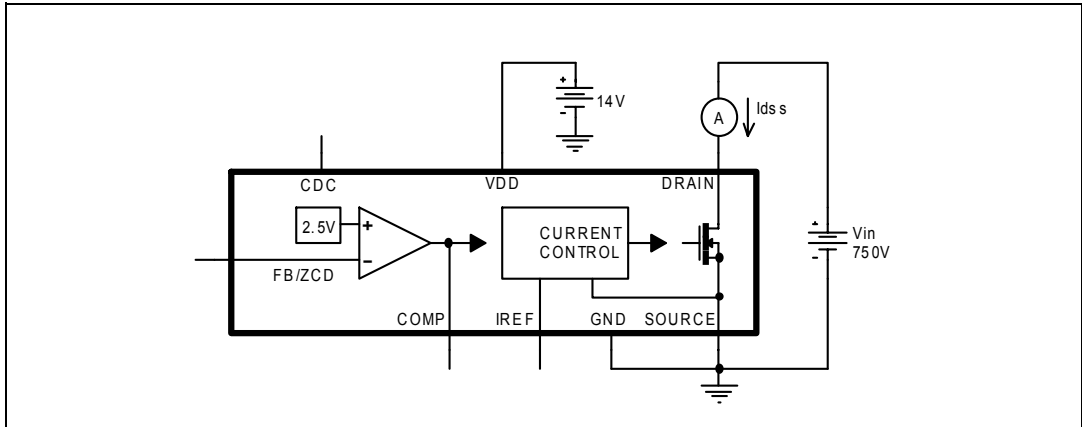

Figure 4. Off state drain and source current test circuit



Note: The measured I_{DSS} is the sum between the current across the start-up resistor and the effective MOSFET's off state drain current.

Figure 5. Start-up current test circuit

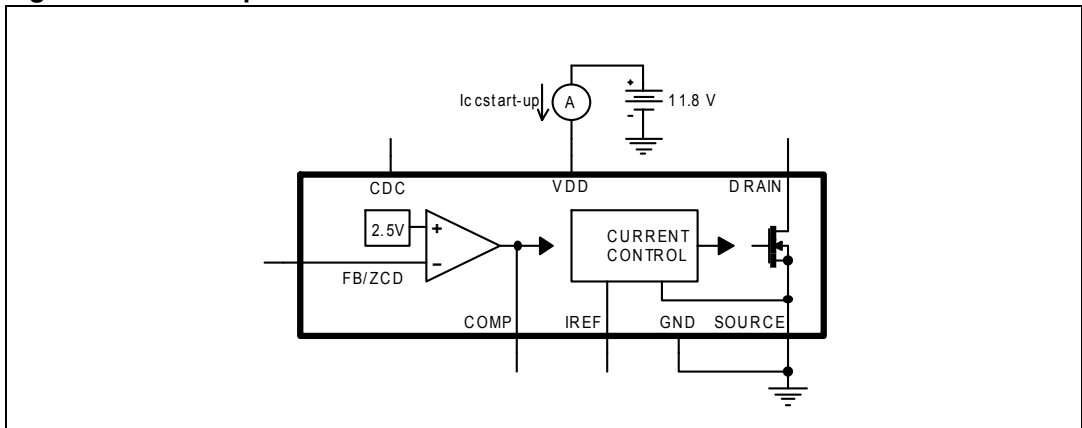

Figure 6. Quiescent current test circuit

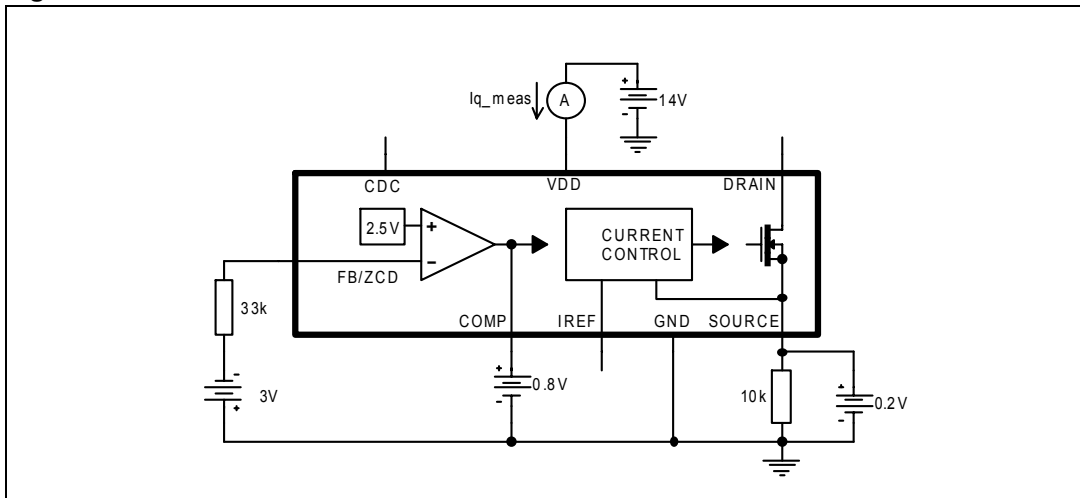
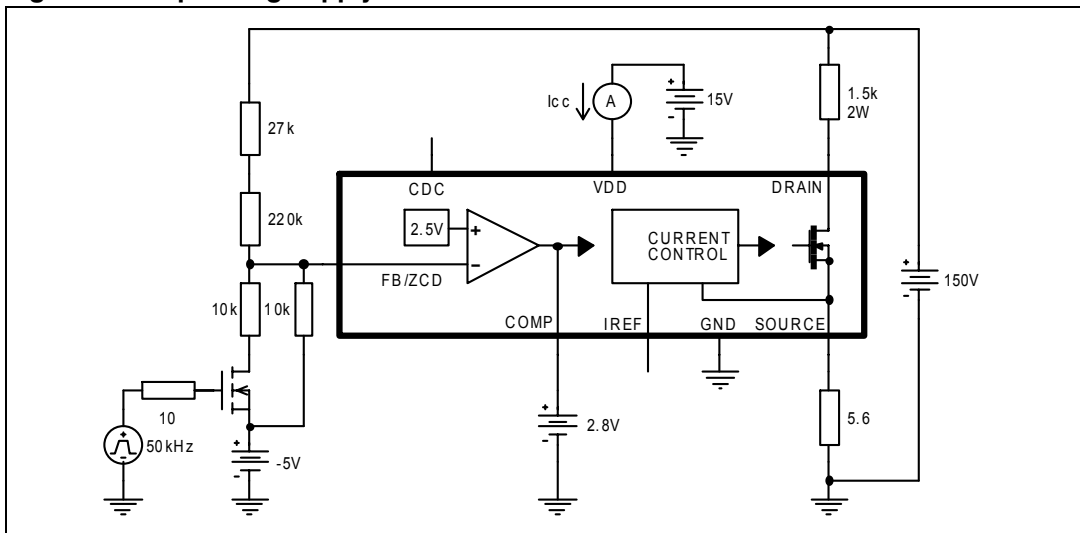
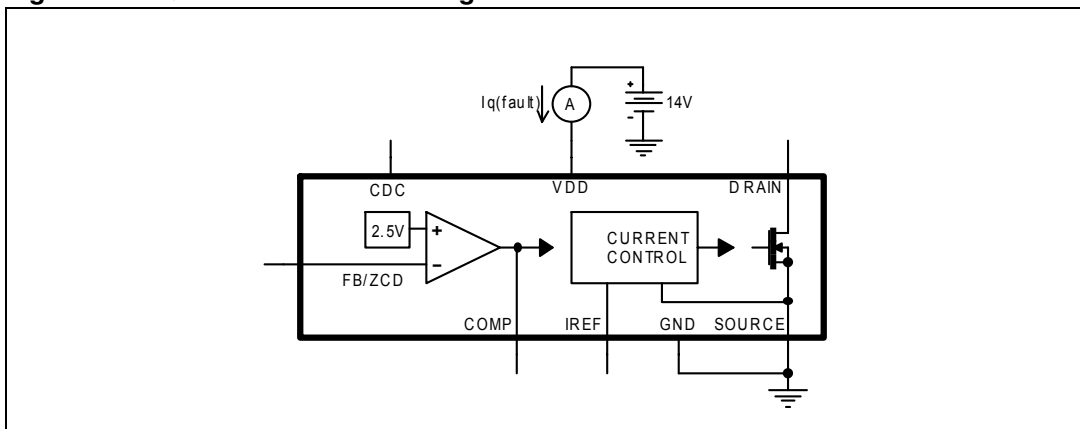

Figure 7. Operating supply current test circuit



Note: The circuit across the ZCD pin is used for switch-on synchronization

Figure 8. Quiescent current during fault test circuit



5 Application information

The device is an off-line all-primary sensing switching regulator, based on quasi-resonant flyback topology.

Depending on converter's load condition, the device is able to work in different modes (see [Figure 9](#)):

1. QR mode at heavy load. Quasi-resonant operation lies in synchronizing MOSFET's turn-on to the transformer's demagnetization by detecting the resulting negative-going edge of the voltage across any winding of the transformer. Then the system works close to the boundary between discontinuous (DCM) and continuous conduction (CCM) of the transformer. As a result, the switching frequency is different for different line/load conditions (see the hyperbolic-like portion of the curves in [Figure 9](#)). Minimum turn-on losses, low EMI emission and safe behavior in short circuit are the main benefits of this kind of operation.
2. Valley-skipping mode at medium/ light load. Depending on voltage on COMP pin, the device defines the maximum operating frequency of the converter. As the load is reduced MOSFET's turn-on does not occur any more on the first valley but on the second one, the third one and so on. In this way the switching frequency is no longer increased (piecewise linear portion in [Figure 9](#)).
3. Burst-mode with no or very light load. When the load is extremely light or disconnected, the converter enters a controlled on/off operation with constant peak current. Decreasing the load result in frequency reduction, which can go down even to few hundred hertz, thus minimizing all frequency-related losses and making it easier to comply with energy saving regulations or recommendations. Being the peak current very low, no issue of audible noise arises.

Figure 9. Multi-mode operation of ALTAIR05T-800

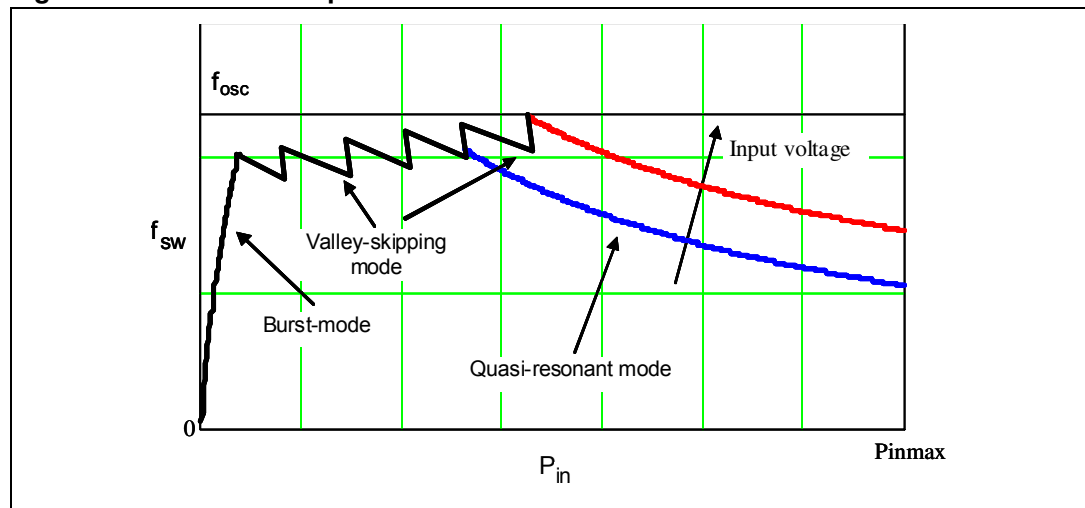

5.1 Power section and gate driver

The power section guarantees safe avalanche operation within the specified energy rating as well as high dv/dt capability. The Power MOSFET has a $V_{(BR)DSS}$ of 800 V min. and a typical $R_{DS(on)}$ of 11 Ω .

The gate driver is designed to supply a controlled gate current during both turn-on and turn-off in order to minimize common mode EMI. Under UVLO conditions an internal pull-down circuit holds the gate low in order to ensure that the power MOSFET cannot be turned on accidentally.

5.2 High-voltage start-up generator

The HV current generator is supplied through the DRAIN pin and it is enabled only if the input bulk capacitor voltage is higher than V_{start} threshold, 50 V_{DC} typically. When the HV current generator is ON, the Icharge current (5.5 mA typical value) is delivered to the capacitor on the V_{CC} pin.

With reference to the timing diagram of [Figure 10](#), when power is applied to the circuit and the voltage on the input bulk capacitor is high enough, the HV generator is sufficiently biased to start operating, thus it draws about 5.5 mA (typical) from the bulk capacitor. Most of this current charges the bypass capacitor connected between the Vcc pin and ground and make its voltage rise linearly.

As the Vcc voltage reaches the start-up threshold (13 V typ.) the chip starts operating, the internal power MOSFET is enabled to switch and the HV generator is cut off. The IC is powered by the energy stored in the Vcc capacitor.

The chip is able to power itself directly from the rectified mains: when the voltage on the V_{CC} pin falls below $V_{CC_{restart}}$ (10.5V typ.), during each MOSFET's off-time the HV current generator is turned on and charges the supply capacitor until it reaches the V_{CCOn} threshold.

In this way, the self-supply circuit develops a voltage high enough to sustain the operation of the device. This feature is useful especially during CC regulation, when the flyback voltage generated by the auxiliary winding alone may not be able to keep Vcc above $V_{CC_{restart}}$.

At converter power-down the system loses regulation as soon as the input voltage falls below V_{Start} . This prevents converter's restart attempts and ensures monotonic output voltage decay at system power-down.

Figure 10. Timing diagram: normal power-up and power-down sequences

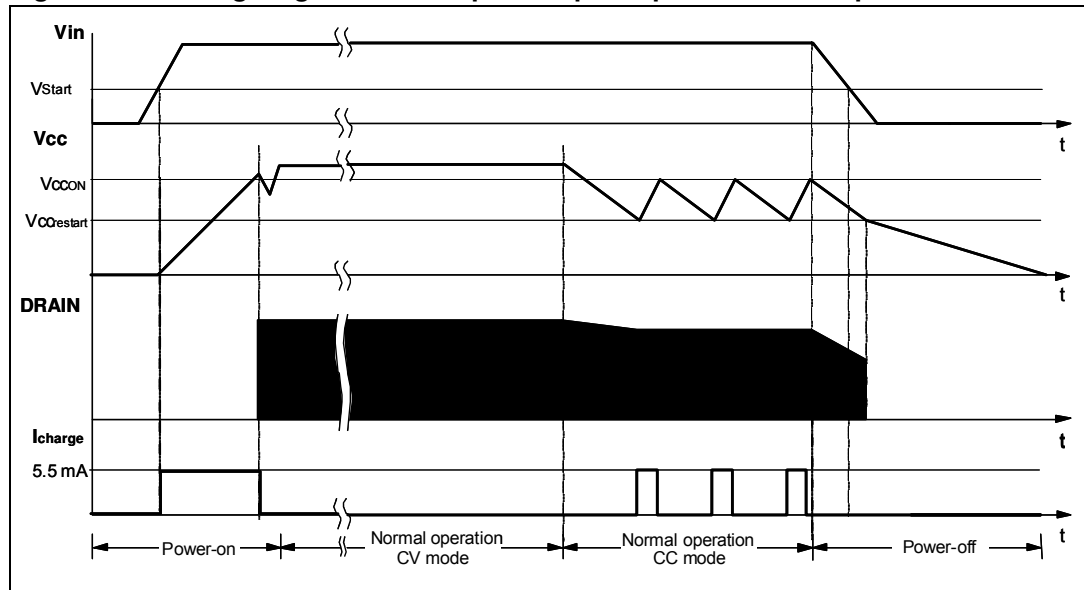

5.3 Zero current detection and triggering block

The zero current detection (ZCD) and triggering blocks switch on the power MOSFET if a negative-going edge falling below 50 mV is applied to the ZCD/FB pin. To do so, the triggering block must be previously armed by a positive-going edge exceeding 100 mV.

This feature is used to detect transformer demagnetization for QR operation, where the signal for the ZCD input is obtained from the transformer’s auxiliary winding used also to supply the IC.

Figure 11. ZCD block, triggering block

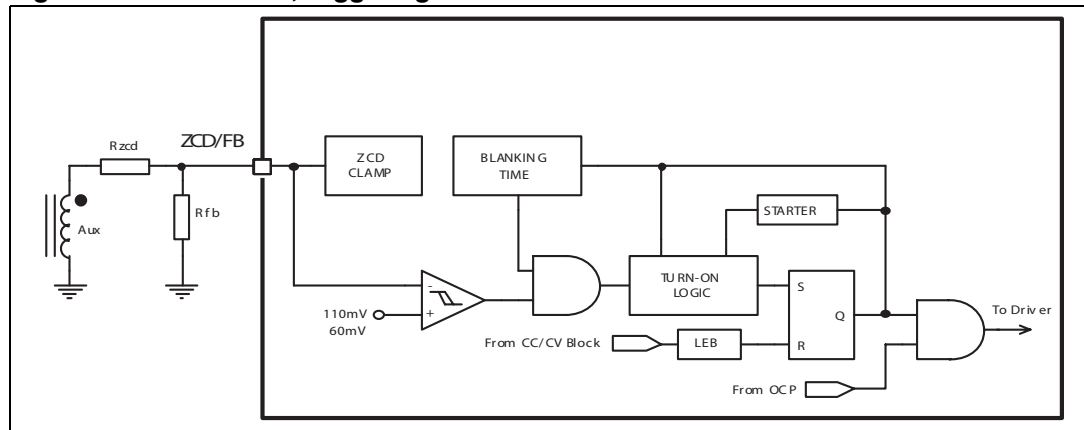

The triggering block is blanked after MOSFET’s turn-off to prevent any negative-going edge that follows leakage inductance demagnetization from triggering the ZCD circuit erroneously.

This blanking time is dependent on the voltage on COMP pin: it is $T_{BLANK} = 30 \mu s$ for $V_{COMP} = 0.9 V$, and decreases almost linearly down to $T_{BLANK} = 6 \mu s$ for $V_{COMP} = 1.3 V$

The voltage on the pin is both top and bottom limited by a double clamp, as illustrated in the internal diagram of the ZCD block of [Figure 11](#). The upper clamp is typically at 3.3 V, while the lower clamp is at -60 mV. The interface between the pin and the auxiliary winding is a resistor divider. Its resistance ratio as well as the individual resistance values has to be properly chosen (see [“Section 5.4: Constant voltage operation”](#) and [“Section 5.6: Voltage feedforward block”](#)).

Please note that the maximum $I_{ZCD/FB}$ sunk/sourced current has to not exceed ± 2 mA (AMR) in all the V_{in} range conditions (85-265 Vac). No capacitor is allowed between ZCD pin and the auxiliary transformer.

The switching frequency is top-limited below 166 kHz, as the converter’s operating frequency tends to increase excessively at light load and high input voltage.

A Starter block is also used to start-up the system, that is, to turn on the MOSFET during converter power-up, when no or a too small signal is available on the ZCD pin.

The starter frequency is 2 kHz if COMP pin is below burst mode threshold, i.e. 1 V, while it becomes 8 kHz if this voltage exceed this value.

After the first few cycles initiated by the starter, as the voltage developed across the auxiliary winding becomes large enough to arm the ZCD circuit, MOSFET’s turn-on starts to be locked to transformer demagnetization, hence setting up QR operation.

The starter is activated also when the IC is in CC regulation and the output voltage is not high enough to allow the ZCD triggering.

If the demagnetization completes – hence a negative-going edge appears on the ZCD pin – after a time exceeding time T_{BLANK} from the previous turn-on, the MOSFET is turned on again, with some delay to ensure minimum voltage at turn-on. If, instead, the negative-going edge appears before T_{BLANK} has elapsed, it is ignored and only the first negative-going edge after T_{BLANK} turns-on the MOSFET. In this way one or more drain ringing cycles is skipped (“valley-skipping mode”, [Figure 12](#)) and the switching frequency is prevented from exceeding $1/T_{BLANK}$.

Figure 12. Drain ringing cycle skipping as the load is progressively reduced

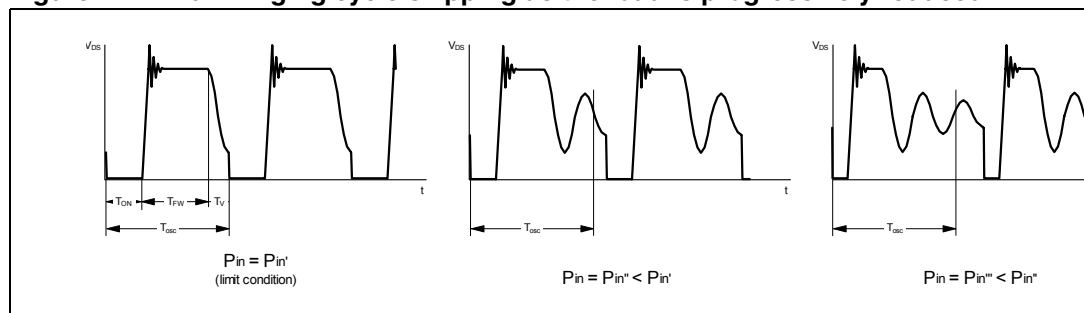

Note that when the system operates in valley skipping-mode, uneven switching cycles may be observed under some line/load conditions, due to the fact that the OFF-time of the MOSFET is allowed to change with discrete steps of one ringing cycle, while the OFF-time needed for cycle-by-cycle energy balance may fall in between. Thus one or more longer switching cycles is compensated by one or more shorter cycles and vice versa. However, this mechanism is absolutely normal and there is no appreciable effect on the performance of the converter or on its output voltage.

5.4 Constant voltage operation

The IC is specifically designed to work in primary regulation and the output voltage is sensed through a voltage partition of the auxiliary winding, just before the auxiliary rectifier diode.

[Figure 13](#) shows the internal schematic of the constant voltage mode and the external connections.

Figure 13. Voltage control principle: internal schematic

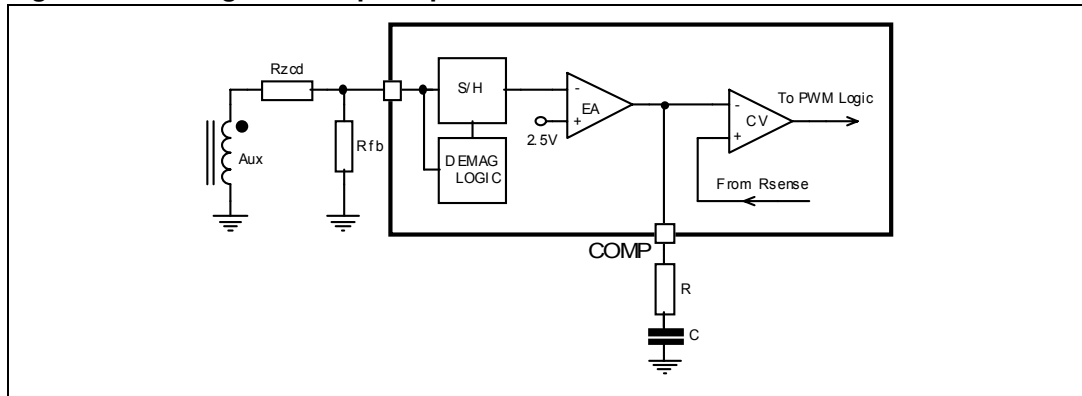

Due to the parasitic wires resistance, the auxiliary voltage is representative of the output just when the secondary current becomes zero. For this purpose, the signal on ZCD/FB pin is sampled-and-held at the end of transformer's demagnetization to get an accurate image of the output voltage and it is compared with the error amplifier internal reference.

The COMP pin is used for the frequency compensation: usually, an RC network, which stabilizes the overall voltage control loop, is connected between this pin and ground.

The output voltage can be defined according the formula:

$$R_{FB} = \frac{V_{REF}}{\frac{N_{AUX}}{N_{SEC}} \cdot V_{OUT} - V_{REF}} \cdot R_{ZCD} \quad (1)$$

Where N_{SEC} and N_{AUX} are the secondary and auxiliary turn's number respectively.

The R_{ZCD} value can be defined depending on the application parameters (see "[Section 5.6: Voltage feedforward block](#)").

5.5 Constant current operation

[Figure 14](#) presents the principle used for controlling the average output current of the flyback converter.

The output voltage of the auxiliary winding is used by the demagnetization block to generate the control signal for the mosfet switch Q1. A resistor R in series with it absorbs a current V_C/R , where V_C is the voltage developed across the capacitor C_{REF}

The flip-flop's output is high as long as the transformer delivers current on secondary side. This is shown in [Figure 15](#).

The capacitor C_{REF} has to be chosen so that its voltage V_C can be considered as a constant. Since it is charged and discharge by currents in the range of some ten μA (I_{CREF} is typically 20 μA) at the switching frequency rate, a capacitance value in the range 4.7-10 nF is suited for switching frequencies in the ten kHz.

The average output current can be expressed as:

$$I_{OUT} = \frac{N_{PRI}}{N_{SEC}} \cdot \frac{V_{CREF}}{(2 \cdot R_{SENSE})} \tag{2}$$

Where N_{PRI} is the primary's turns number.

This formula shows that the average output current does not depend anymore on the input or the output voltage, neither on transformer inductance values. The external parameters defining the output current are the transformer ratio n and the sense resistor R_{SENSE} .

Figure 14. Current control principle

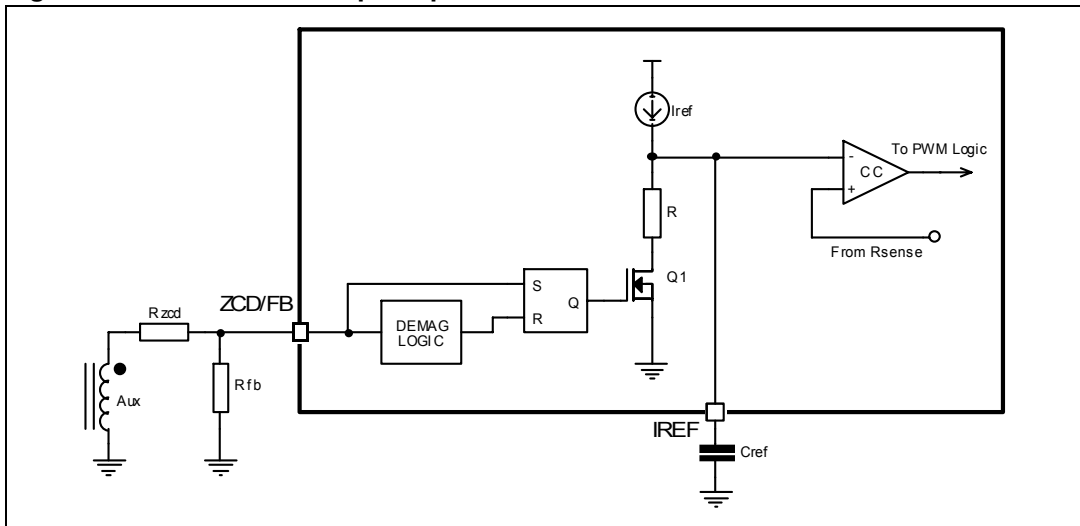
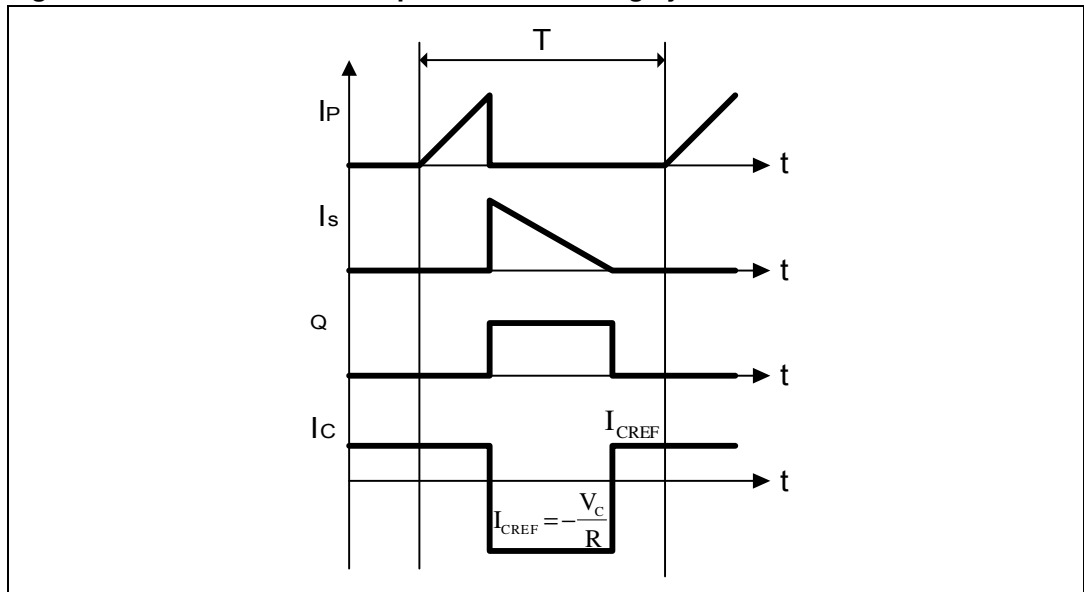

Figure 15. Constant current operation: Switching cycle waveforms



5.6 Voltage feedforward block

The current control structure uses the voltage V_C to define the output current, according to (2). Actually, the CC comparator is affected by an internal propagation delay T_d , which switches off the MOSFET with a peak current than higher the foreseen value.

This current overshoot is equal to:

$$\Delta I_p = \frac{V_{IN} \cdot T_d}{L_p} \quad (3)$$

Where L_p is the primary inductance.

It introduces an error on the calculated CC setpoint, depending on the input voltage.

The device implements a Line Feedforward function, which solves the issue by introducing an input voltage dependent offset on the current sense signal, in order to adjust the cycle-by-cycle current limitation.

The internal schematic is shown in [Figure 16](#).

Figure 16. Feedforward compensation: internal schematic

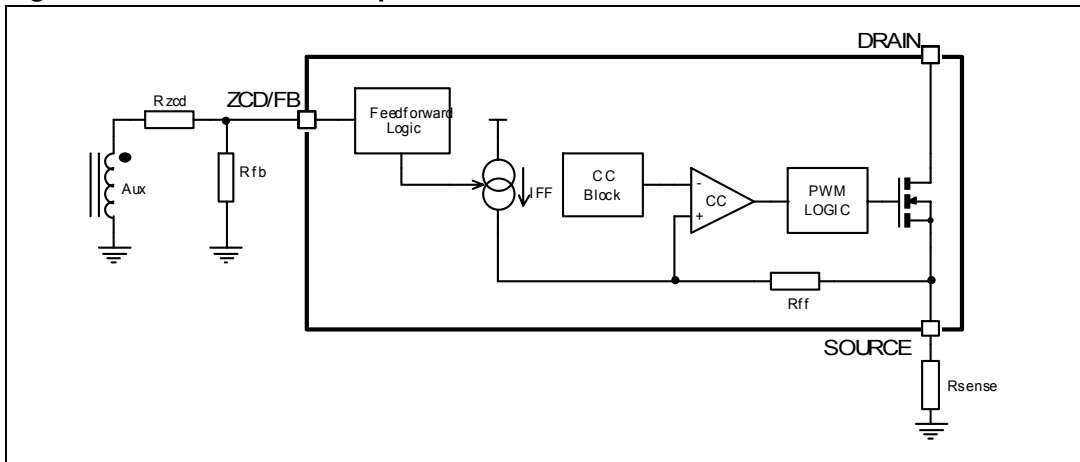

The R_{ZCD} resistor can be calculated as follows:

$$R_{ZCD} = \frac{N_{AUX}}{N_{PRI}} \cdot \frac{L_P \cdot R_{FF}}{T_d \cdot R_{SENSE}} \tag{4}$$

In this case the peak drain current does not depend on input voltage anymore.

One more consideration concerns the R_{ZCD} value: during MOSFET's ON-time, the current sourced by the ZCD/FB pin, I_{ZCD} , is compared with an internal reference current I_{ZCDON} (-50 μ A typical).

If $I_{ZCD} < I_{ZCDON}$, the brownout function is activated and the IC is shut-down.

This feature is especially important when the auxiliary winding is accidentally disconnected and considerably increases the end-product's safety and reliability.

5.7 Cable drop compensation (CDC)

The voltage control loop regulates the output voltage as seen across the output capacitor.

If an output cable is used to supply the load, the voltage at the externally available terminals is dependent on the output current value. The CDC function compensates the voltage drop across the cable, so ideally zero load regulation can be achieved also at the end of the cable.

Figure 17 presents the internal schematic.

Figure 17. CDC block: internal schematic

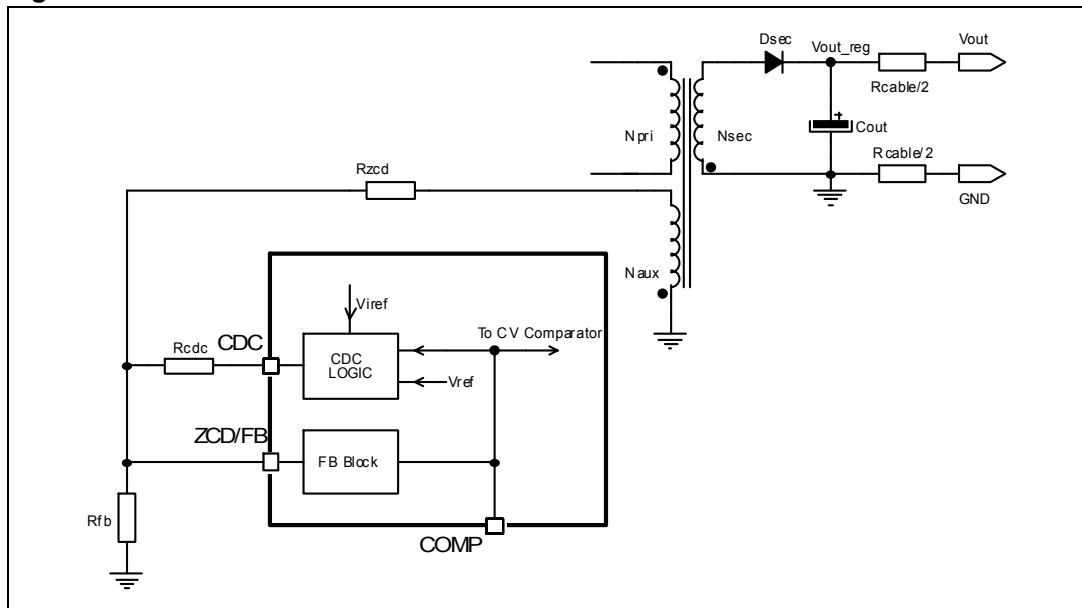

During CV regulation, as the CDC block is capable of sinking current, a resistor connect between its output and ZCD/FB pin allows to increase the CV setpoint, by providing a voltage lower than the internal reference voltage by an amount proportional to the average load current.

If R_{CABLE} is the total cable resistance, the resistor value can be calculated by using the following equation:

$$R_{CDC} = \frac{2 \cdot N_{SEC}}{N_{PRI}} \cdot \frac{N_{SEC}}{N_{AUX}} \cdot \frac{R_{SENSE} \cdot R_{ZCD}}{R_{CABLE}} \quad (5)$$

In this equation R_{CABLE} is the total resistance of the output cable.

The CDC block acts as an outer control loop with a positive feedback that changes the CV setpoint. As such, it can impact on the overall system's stability. In order to avoid any issue that could make unstable the loop, the CV setpoint response time must be much slower than that of the inner voltage loop.

For this purpose the CDC block is designed with a time response of a few ten ms. For the same reason, the minimum voltage on CDC pin is bottom limited at to 2.25 V.

If the function is not required, the pin can be connected to ground or left open.

5.8 Burst-mode operation at no load or very light load

When the voltage at the COMP pin falls 65 mV below a threshold fixed internally at a value, V_{COMPL} , the IC is disabled with the MOSFET kept in OFF state and its consumption reduced at a lower value to minimize V_{CC} capacitor discharge.

In this condition the converter operates in burst-mode (one pulse train every $T_{START}=500 \mu s$), with minimum energy transfer.

As a result of the energy delivery stop, the output voltage decreases: after 500 μs the controller switches-on the MOSFET again and the sampled voltage on the ZCD pin is compared with the internal reference. If the voltage on the EA output, as a result of the comparison, exceeds the V_{COMPL} threshold, the device restarts switching, otherwise it stays OFF for another 500 μs period.

In this way the converter works in burst-mode with a nearly constant peak current defined by the internal disable level. Then a load decrease causes a frequency reduction, which can go down even to few hundred hertz, thus minimizing all frequency-related losses and making it easier to comply with energy saving regulations. This kind of operation, shown in the timing diagrams of *Figure 18* along with the others previously described, is noise-free since the peak current is low

Figure 18. Load-dependent operating modes: timing diagrams

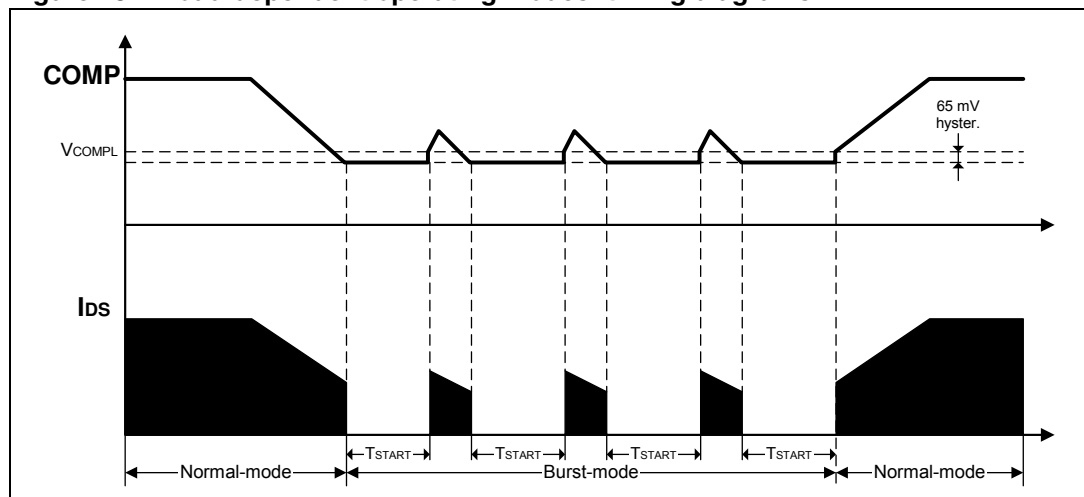

5.9 Soft-start and starter block

The soft start feature is automatically implemented by the constant current block, as the primary peak current is limited from the voltage on the C_{REF} capacitor.

During start-up, as the output voltage is zero, the IC starts in CC mode with no high peak current operations. In this way the voltage on the output capacitor increases slowly and the soft-start feature is ensured.

Actually the C_{REF} value is not important to define the soft-start time, as its duration depends on others circuit parameters, like transformer ratio, sense resistor, output capacitors and load. The user can define the best appropriate value by experiments.

5.10 Hiccup mode OCP

The device is also protected against short circuit of the secondary rectifier, short circuit on the secondary winding or a hard-saturated flyback transformer. A comparator monitors continuously the voltage on the R_{SENSE} and activates a protection circuitry if this voltage exceeds 1 V.

To distinguish an actual malfunction from a disturbance (e.g. induced during ESD tests), the first time the comparator is tripped the protection circuit enters a “warning state”. If in the subsequent switching cycle the comparator is not tripped, a temporary disturbance is assumed and the protection logic is reset in its idle state; if the comparator is tripped again a real malfunction is assumed and the device is stopped.

This condition is latched as long as the device is supplied. While it is disabled, however, no energy is coming from the self-supply circuit; hence the voltage on the V_{CC} capacitor decays and cross the UVLO threshold after some time, which clears the latch. The internal start-up generator is still off, then the V_{CC} voltage still needs to go below its restart voltage before the V_{CC} capacitor is charged again and the device restarted. Ultimately, this results in a low-frequency intermittent operation (Hiccup-mode operation), with very low stress on the power circuit. This special condition is illustrated in the timing diagram of [Figure 19](#).

Figure 19. Hiccup-mode OCP: timing diagram

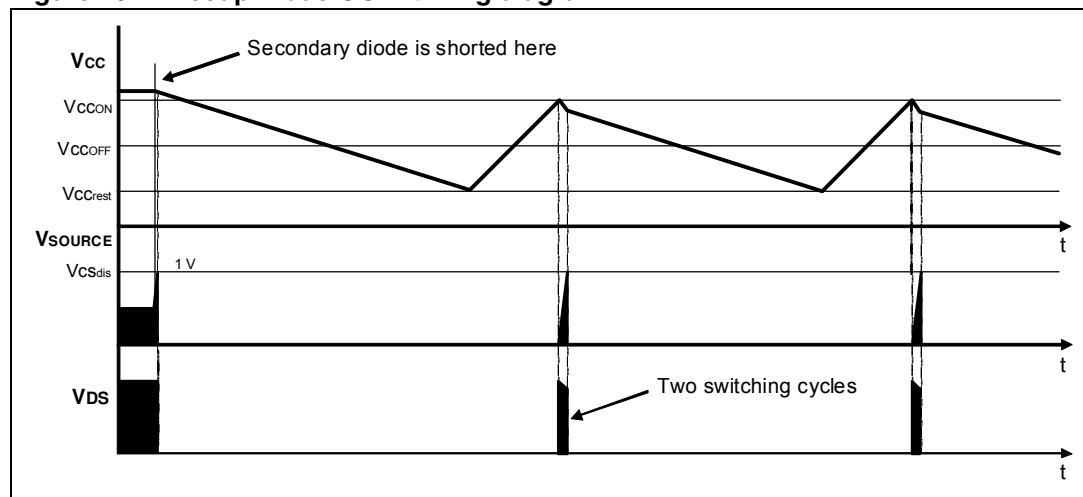

5.11 Layout recommendations

A proper printed circuit board layout is essential for correct operation of any switch-mode converter and this is true for the ALTAIR05T-800 as well. Careful component placing, correct traces routing, appropriate traces widths and compliance with isolation distances are the major issues. In particular:

- The compensation network should be connected as close as possible to the COMP pin, maintaining the trace for the GND as short as possible
- Signal Ground should be routed separately from power ground, as well from the sense resistor trace.

Figure 20. Suggested routing for converter

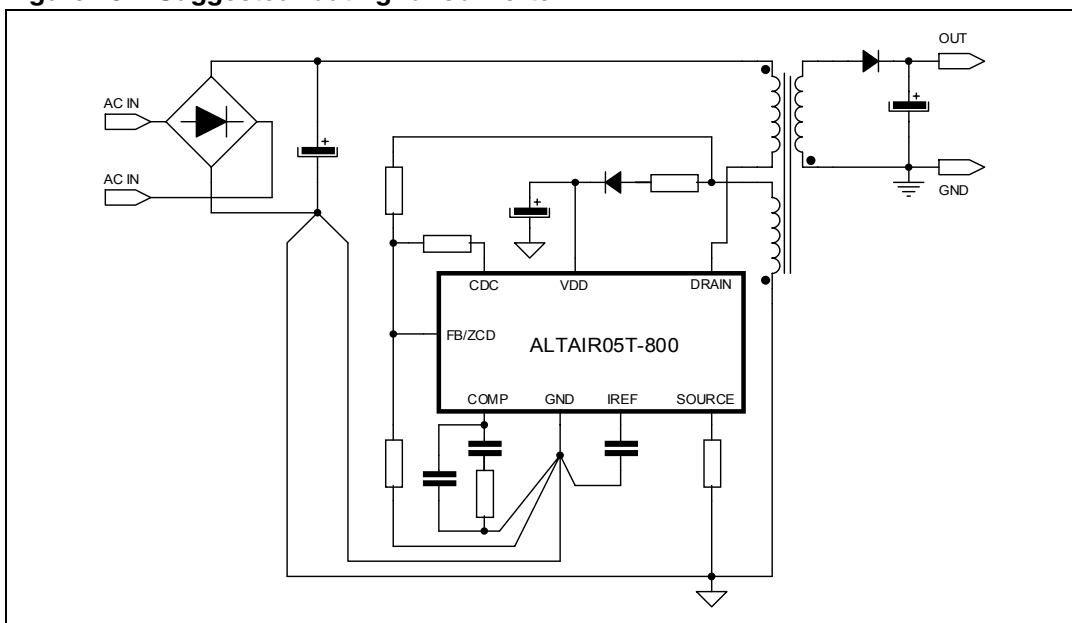

6 Typical application

Figure 21. Test board schematic: 5 W wide range mains CC/CV battery charger

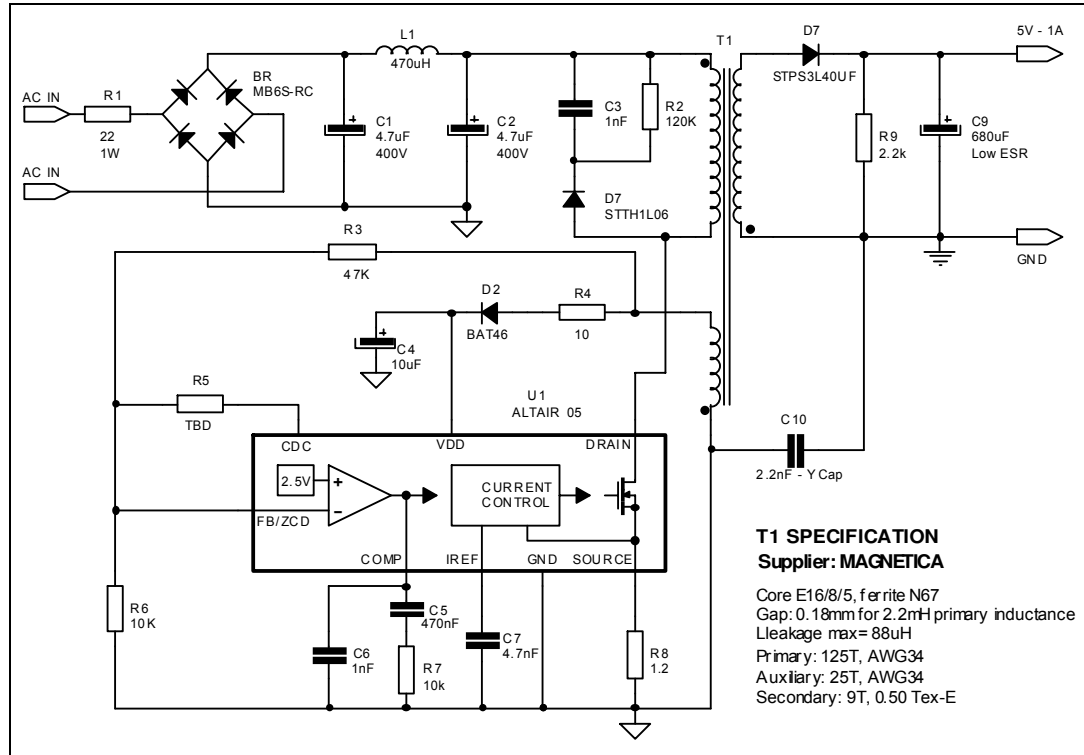

Table 5. Efficiency at 115 V_{AC}

Load [%]	I _{OUT} [A]	V _{OUT} [V]	P _{OUT} [W]	P _{IN} [W]	Efficiency [%]
25	0.25	4.97	1.243	1.643	75.62
50	0.5	4.97	2.485	3.156	78.64
75	0.75	4.97	3.728	4.72	78.97
100	1	4.98	4.980	6.4	77.81
Average efficiency					77.79

Table 6. Efficiency at 230 V_{AC}

Load [%]	I _{OUT} [A]	V _{OUT} [V]	P _{OUT} [W]	P _{IN} [W]	Efficiency [%]
25	0.25	4.98	1.245	1.88	66.22
50	0.5	4.97	2.485	3.349	74.18
75	0.75	4.98	3.735	4.838	77.22
100	1	4.99	4.990	6.326	78.88
Average efficiency					74.12

7 Package mechanical data

In order to meet environmental requirements, ST offers these devices in different grades of ECOPACK[®] packages, depending on their level of environmental compliance. ECOPACK[®] specifications, grade definitions and product status are available at: www.st.com. ECOPACK[®] is an ST trademark.

Table 7. SO16N mechanical data

Dim.	Mm			inch		
	Min	Typ	Max	Min	Typ	Max
A			1.75			0.069
a1	0.1		0.25	0.004		0.009
a2			1.6			0.063
b	0.35		0.46	0.014		0.018
b1	0.19		0.25	0.007		0.010
C		0.5			0.020	
c1			45°	(typ.)		
D (1)	9.8		10	0.386		0.394
E	5.8		6.2	0.228		0.244
e		1.27			0.050	
e3		8.89			0.350	
F(1)	3.8		4.0	0.150		0.157
G	4.60		5.30	0.181		0.208
L	0.4		1.27	0.150		0.050
M			0.62			0.024
S	8 °(max.)					

Figure 22. Package dimensions

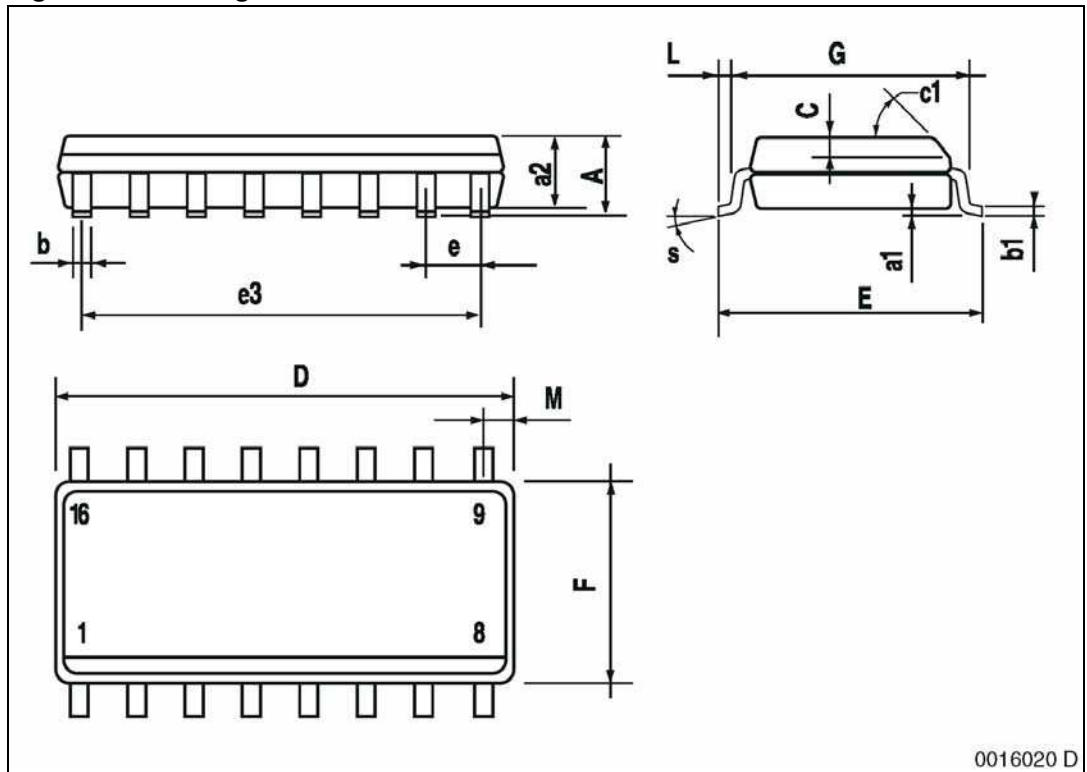

8 Order codes

Table 8. Ordering information

Order code	Package	Packaging
ALTAIR05T-800	SO16N	Tube
ALTAIR05T-800TR		Tape and reel

9 Revision history

Table 9. Document revision history

Date	Revision	Changes
25-Oct-2010	1	Initial release.

Please Read Carefully:

Information in this document is provided solely in connection with ST products. STMicroelectronics NV and its subsidiaries ("ST") reserve the right to make changes, corrections, modifications or improvements, to this document, and the products and services described herein at any time, without notice.

All ST products are sold pursuant to ST's terms and conditions of sale.

Purchasers are solely responsible for the choice, selection and use of the ST products and services described herein, and ST assumes no liability whatsoever relating to the choice, selection or use of the ST products and services described herein.

No license, express or implied, by estoppel or otherwise, to any intellectual property rights is granted under this document. If any part of this document refers to any third party products or services it shall not be deemed a license grant by ST for the use of such third party products or services, or any intellectual property contained therein or considered as a warranty covering the use in any manner whatsoever of such third party products or services or any intellectual property contained therein.

UNLESS OTHERWISE SET FORTH IN ST'S TERMS AND CONDITIONS OF SALE ST DISCLAIMS ANY EXPRESS OR IMPLIED WARRANTY WITH RESPECT TO THE USE AND/OR SALE OF ST PRODUCTS INCLUDING WITHOUT LIMITATION IMPLIED WARRANTIES OF MERCHANTABILITY, FITNESS FOR A PARTICULAR PURPOSE (AND THEIR EQUIVALENTS UNDER THE LAWS OF ANY JURISDICTION), OR INFRINGEMENT OF ANY PATENT, COPYRIGHT OR OTHER INTELLECTUAL PROPERTY RIGHT.

UNLESS EXPRESSLY APPROVED IN WRITING BY AN AUTHORIZED ST REPRESENTATIVE, ST PRODUCTS ARE NOT RECOMMENDED, AUTHORIZED OR WARRANTED FOR USE IN MILITARY, AIR CRAFT, SPACE, LIFE SAVING, OR LIFE SUSTAINING APPLICATIONS, NOR IN PRODUCTS OR SYSTEMS WHERE FAILURE OR MALFUNCTION MAY RESULT IN PERSONAL INJURY, DEATH, OR SEVERE PROPERTY OR ENVIRONMENTAL DAMAGE. ST PRODUCTS WHICH ARE NOT SPECIFIED AS "AUTOMOTIVE GRADE" MAY ONLY BE USED IN AUTOMOTIVE APPLICATIONS AT USER'S OWN RISK.

Resale of ST products with provisions different from the statements and/or technical features set forth in this document shall immediately void any warranty granted by ST for the ST product or service described herein and shall not create or extend in any manner whatsoever, any liability of ST.

ST and the ST logo are trademarks or registered trademarks of ST in various countries.

Information in this document supersedes and replaces all information previously supplied.

The ST logo is a registered trademark of STMicroelectronics. All other names are the property of their respective owners.

© 2010 STMicroelectronics - All rights reserved

STMicroelectronics group of companies

Australia - Belgium - Brazil - Canada - China - Czech Republic - Finland - France - Germany - Hong Kong - India - Israel - Italy - Japan - Malaysia - Malta - Morocco - Philippines - Singapore - Spain - Sweden - Switzerland - United Kingdom - United States of America

www.st.com